

Series 23e

PTFE-lined Rotary Plug Valve

Application:

PTFE-lined rotary plug valve for aggressive media, especially due to high demands in chemical plants:

- Nominal diameter: DN 25, DN 50 and DN 80 as well as 1", 2" and 3" (DN 100 and 4" in preparation)
- Nominal pressure: PN 10 and ANSI Class 150
- Temperatures: -10°C to 200°C (14°F to 392°F)

The valve consists of a PTFE-lined rotary plug valve and a pneumatic actuator.

The valve is designed to the modular-assembly principle and has the following features:

- Pocket free, with a high flow capacity
- One-pieced body lining consisting of chemical-resistant PTFE (average body lining, 5 mm)
- Live-loaded PTFE V-ring packing to seal stem
- Bottom end of stem without any leakage (closed liner)
- Possible attachments acc. DIN ISO 5211
- DIN face-to-face dimensions acc. to DIN EN 558-1, Series 1
- ANSI face-to-face dimensions acc. to DIN EN 558-2, Series 37

Versions:

Series 23e PTFE-lined Rotary Plug Valve, optionally in the following versions:

- Manually operated rotary plug valve with manual gear
- Automated rotary plug valve with shut-off function, with BR 31a AT Rotary Actuator
- Automated rotary plug valve with control function, optimally with BR 30a Diaphragm Rotary Actuator (refer to data sheet for details)

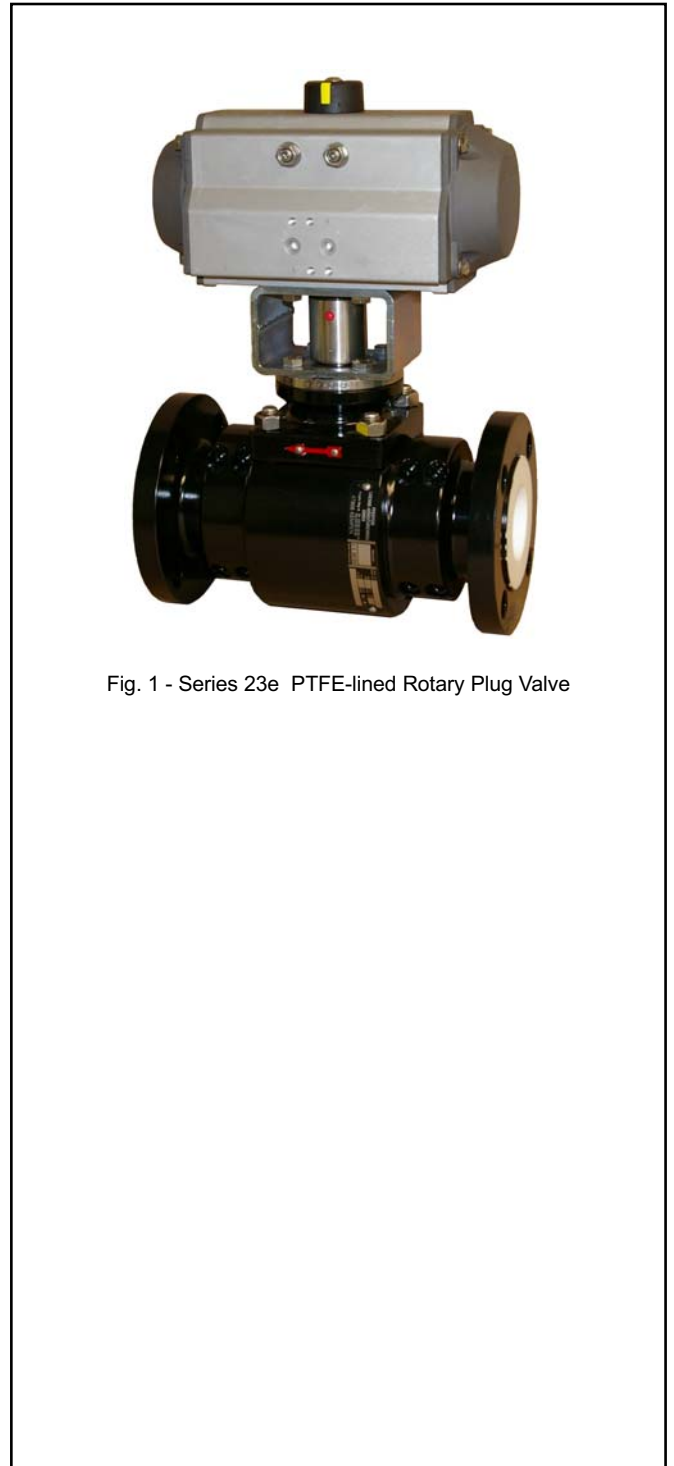

Fig. 1 - Series 23e PTFE-lined Rotary Plug Valve

Rotary plug valve Series 23e

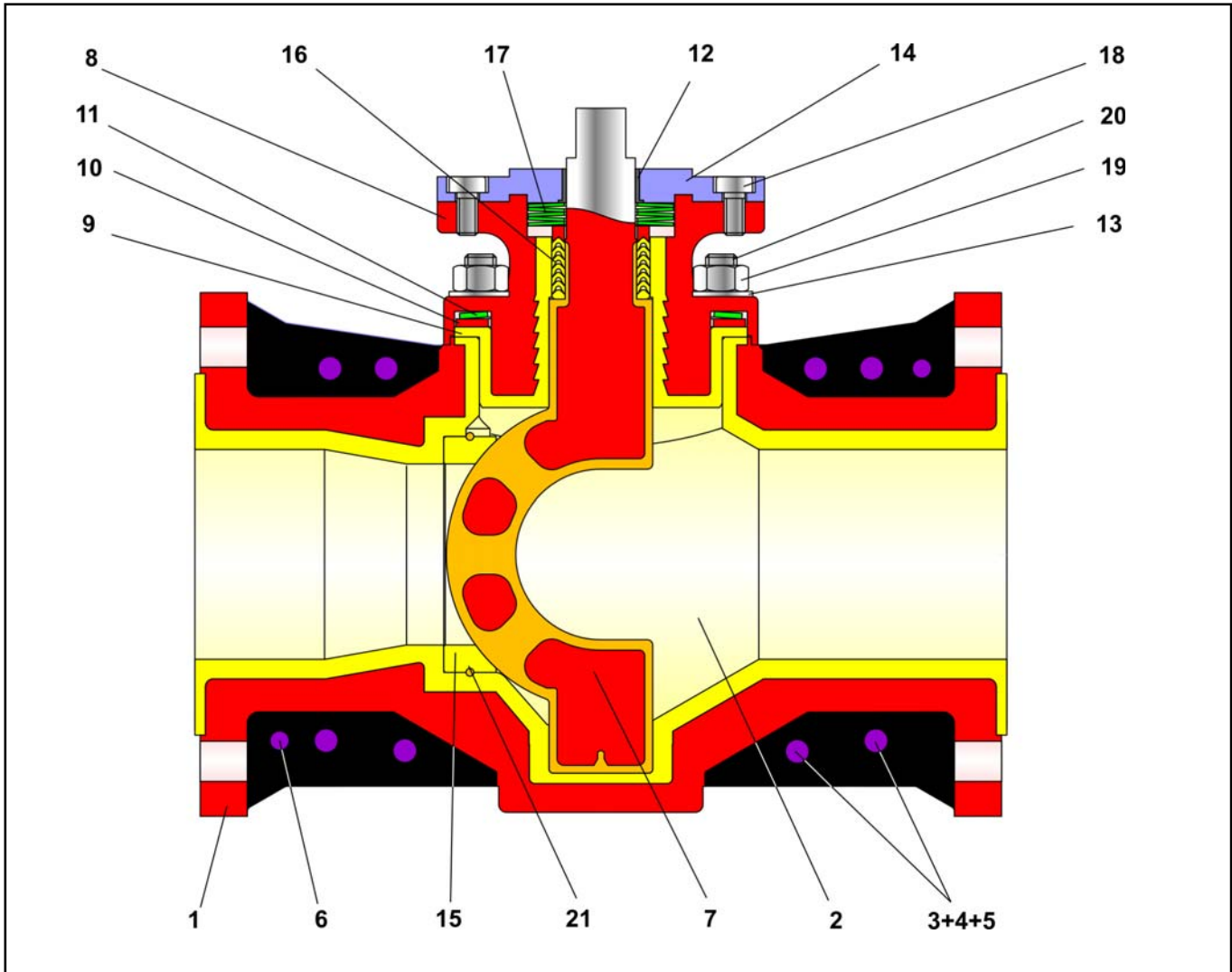

Fig. 2 - Series 23e PTFE-lined Rotary Plug Valve

Item	Description
1	Rotary plug valve body
2	Liner for valve body
3	Screw
4	Washer
5	Nut
6	Straight pin
7	Rotary plug
8	Bonnet flange
9	Liner for bonnet flange
10	Thrust ring
11	Spring washer

Item	Description
12	Bearing bushing
13	Washer
14	Stuffing box
15	Seat ring
16	V-ring packing
17	Set of spring washers
18	Screw
19	Nut
20	Stud bolt
21	Cord

Table 1 - List of parts

Special designs:

- Various Kvs coefficients
- PTFE-conductive lining
- Heating
- Various materials on request

Additional equipment:

For the control valves, the following accessories are available either individually or in combination:

- Pneumatic and electric actuators
- Positioner
- Limit switch
- Solenoid valves
- Air pressure reducing stations with filter

Further accessories are available on request for customer specifications

When the process medium flows through the valve in **direction A**, the rotary plug is slightly pressed out of the seat. This reduces the pre-loaded pressure and the breakaway torque.

When the process medium flows through the valve in **direction B**, the pre-loaded pressure increases, with a rise in the breakaway torque.

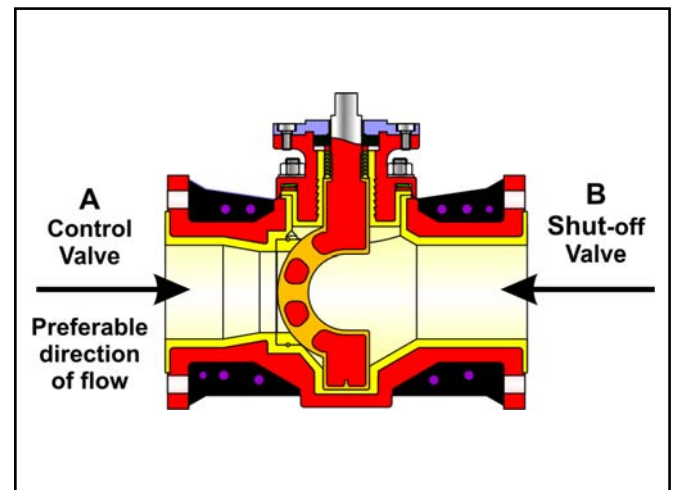

Fig. 3 - Direction of flow

Function and operating principle:

The Series 23e Rotary Plug Valves permit full flow through the valve in both directions.

The position of the rotary plug (7) determines the flow rate between the rotary plug and seat ring (15). The seat ring is used to seal the rotary plug.

The version illustrated ensures excellent shut-off performance, a large flow capacity and easy replacement of the seat ring.

The stem is sealed by a maintenance-free PTFE V-ring packing (16) loaded by spring washers (17) located above the packing.

The actuator is mounted on a mounting flange. The connecting dimensions conform to DIN ISO 5211.



Note: Before using the rotary plug valve in hazardous areas, check whether this is possible according to ATEX 94/9/EC. See Operating Instructions <BA 23e>.



Fail-safe position:

Depending on how the pneumatic actuator is mounted to the valve, the rotary plug valve has two fail-safe positions which become effective when the air pressure in the actuator is relieved or when the supply air fails:

- **Rotary plug valve with actuator fail-to-close**
On failure of the air supply, the rotary plug valve closes. The rotary plug valve opens as the signal pressure rises, overcoming the force of the springs.
- **Rotary plug valve with actuator fail-to-open**
On failure of the air supply, the rotary plug valve opens. The rotary plug valve closes as the signal pressure rises, overcoming the force of the springs.

Rotary plug valve Series 23e

Dimensions and weights:

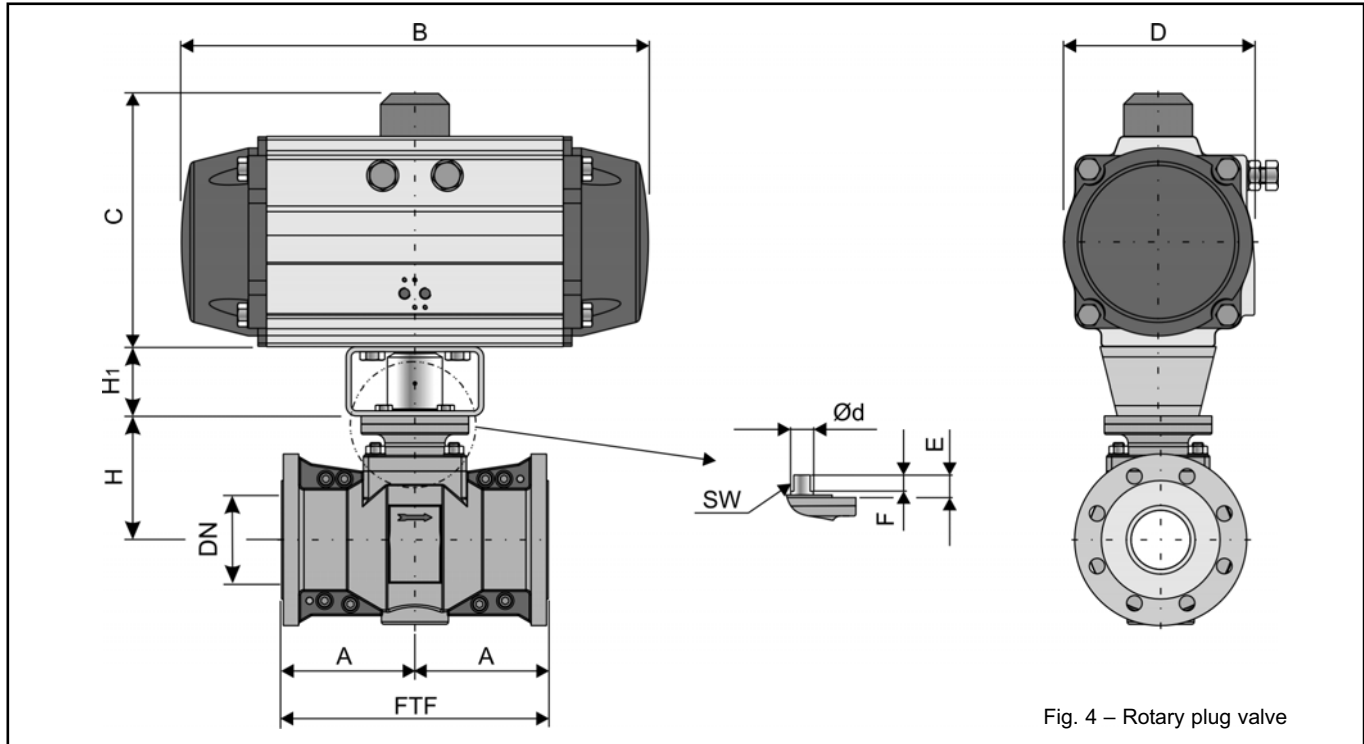

Fig. 4 – Rotary plug valve

DN / Size		25 / 1"	50 / 2"	80 / 3"
FTF	PN 10	160	230	310
	ANSI 150 lbs	184	254	298
A	PN 10	80	115	155
	ANSI 150 lbs	92	127	149
E		21	21.7	26.2
F		15	17	19
H		65	100.8	144.3
Ød		20	22	27
DIN ISO Connection		F05	F07	F10
SW		14	17	19
Weight in kg		ca. 8	ca. 12	ca. 31

Actuator Series 31a, Type SRP	60	100	150	220	300	450	600	900	1200
B	210.5	247.5	268.5	315	345	408.5	437.5	487	543
C	102	115	127	145	157	177	196	220.5	245
D	94.5	106.3	123	141	151.5	171.5	187	204	222
DIN ISO Connection	F05	F07	F07	F10	F10	F12	F12	F14	F14
Square end	14	17	17	22	22	27	27	36	36
max. weight	3.2	4.4	6.5	9.8	12.6	18.1	24	31.6	45.1

Valve	F05	F05	F07	F05	F07	F10	F05	F07	F10	F12	F07	F10	F12	F14
Actuator	F05	F07	F07	F10	F10	F10	F12	F12	F12	F12	F14	F14	F14	F14
H1	60			80						90				

Table 2 - Dimensions in mm and weights in kg

Technical data:

Nominal size	DN 25, 50 and 80 as well as 1", 2 "and 3"
Nominal pressure	PN 10 as well as ANSI 150 lbs
Temperature range	-10°C to 200°C (14°F to 392°F)
Rotary plug sealing	PTFE
Leakage - shut-off valve	Leakage rate A acc. to DIN EN 12266-1, P12 (Leakage rate 1 BO acc. to DIN 3230 Part 3)
Leakage - control valve	0,001% of kvs-coefficient
Flanges	as per DIN EN 1092-1, Form B1
Stuffing box packing	cup live-loaded PTFE V-ring packing
Face to face dimensions	DIN FTF acc. to DIN EN 558-1, Series 1 / ANSI FTF acc. to DIN EN 558-2, Series 37

Table 3 - Technical data

Materials:

Rotary plug valve body	0.7043
Liner for valve body	PTFE
Bonnet flange	0.7043
Liner for bonnet flange	PTFE
Rotary plug and shaft	1.4313 with TFM-coating
Seat ring	PTFE
V-ring packing	PTFE V-ring-packing with spring washers of 1.8159, Delta Tone
Bearing bushing	PTFE with 25% carbon
Spring washer	1.8159
Coating	Two-component polyurethane, color: black, RAL 90055

Table 4 - Materials

kvs - values

kvs	6.3	10	16	25	30	40	63	80	100
DN									
25	X	X							
50	X	X	X	X	X				
80				X	X	X	X	X	X

Table 5 - kvs-value

Terms for noise level calculation:

z values for noise level calculation acc. to VDMA 24422

DN	25	60	80	100	150
z	0.15	0.15	0.1	0.1	0.1

Table 6 - Noise-dependent control valve variable z according to VDMA 24422

Correction terms:

with liquids $\Delta LF = 0$, with gases and vapor $\Delta LG = 0$

Terms for control valve sizing:

for control valve sizing acc. to DIN EN 60534 opening angle.

Opening angle φ	30°	40°	50°	60°	70°	80°	90°
FL	0.75	0.73	0.72	0.70	0.59	0.55	0.55
xT	0.47	0.45	0.44	0.41	0.30	0.26	0.25

Table 7 – Terms for control valve sizing

Rotary plug valve Series 23e

Advantages of the live-loaded sealing system:

- Maintenance-free and self-adjusting
- Highest level of sealing performance, even under extreme pressure and temperature changes
- Longer service life
- **all in all:
extremely economic!**

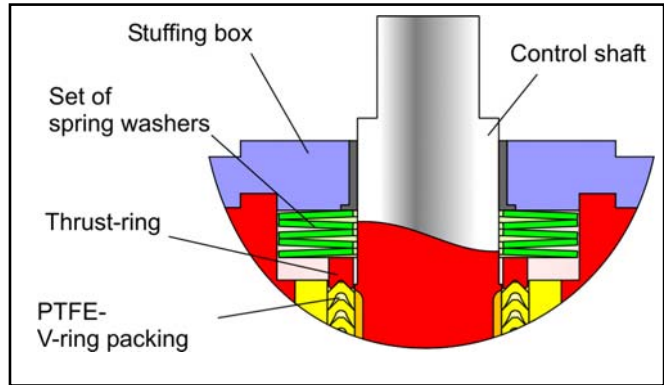

Fig. 5 - Live-loaded packing

Kvs coefficients

DN	φ Opening angle								
	10°	20°	30°	40°	50°	60°	70°	80°	90°
25 / 1"	0.05	1.2	2.6	5.3	9.1	14	20	24	26
50 / 2"	0.22	3.2	11	21	39	60	86	108	114
80 / 3"	0.35	16	38	67	105	152	219	264	280

Table 8 - Kvs coefficients

Cv coefficients

DN	φ Opening angle								
	10°	20°	30°	40°	50°	60°	70°	80°	90°
25 / 1"	0.06	1.4	3.1	6.2	11	16	23	28	31
50 / 2"	0.26	3.7	13	25	46	70	101	126	133
80 / 3"	0.41	19	45	79	123	178	256	308	327

Table 9 - Cv coefficients

Characteristic curve:

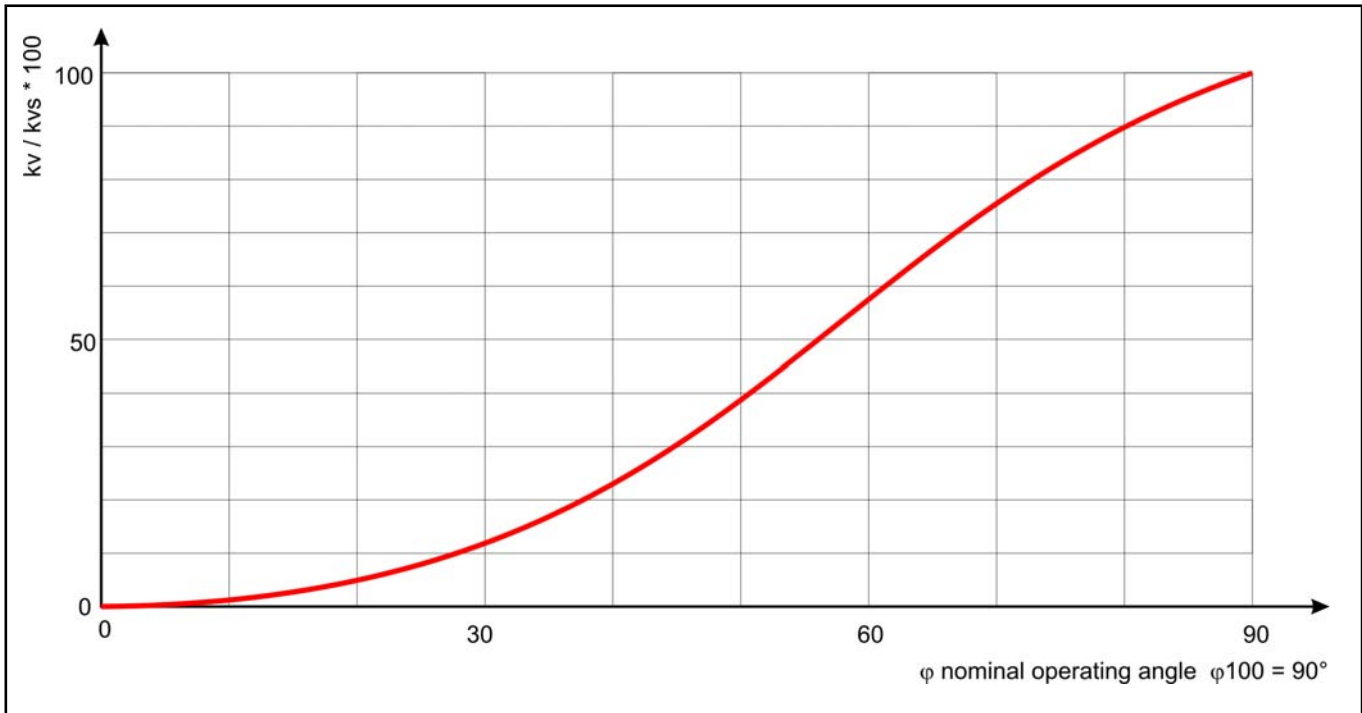

Fig. 6 - Characteristic curve

Pressure-temperature diagram:

The area of application is determined by the pressure-temperature diagram. Process data and the process medium can affect the values in the diagram.

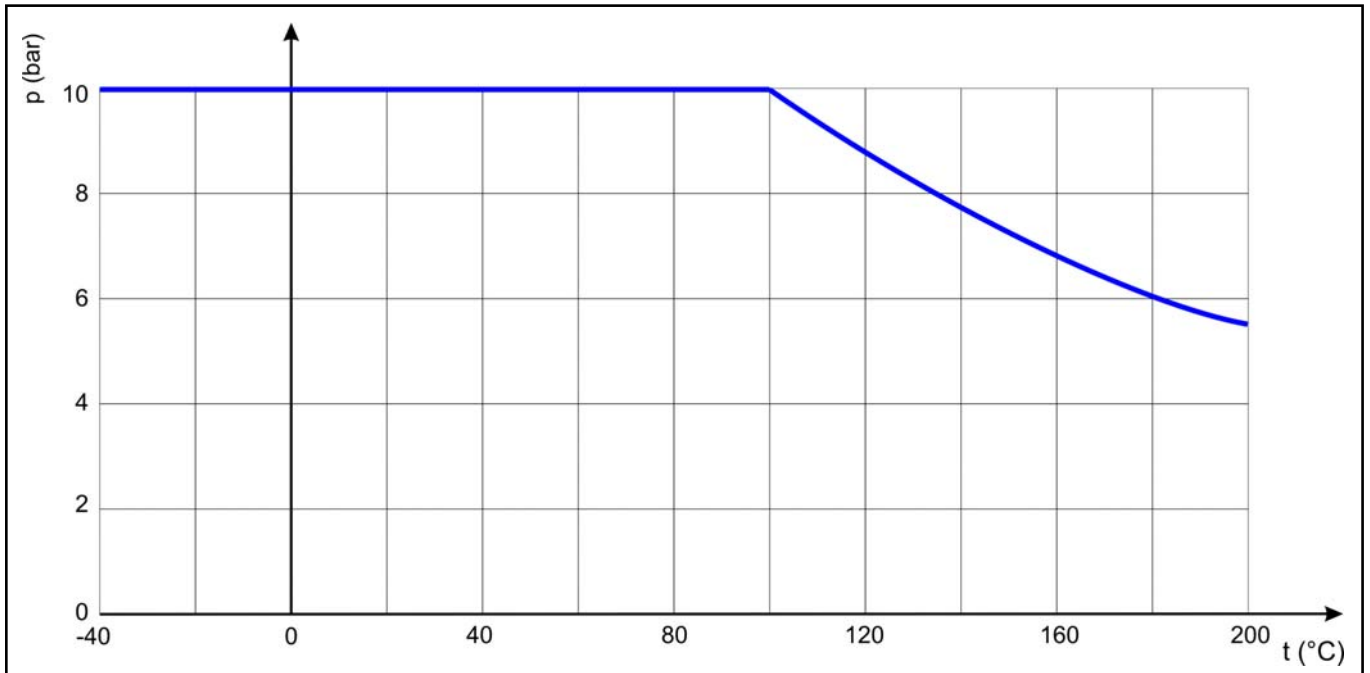

Fig. 7 - Pressure-temperature diagram



Note:

The operating data for the control application need to be calculated to avoid flashing or cavitation.

- The following formula applies: a) $\Delta p < P2$
b) $\Delta p < 3 \text{ bar}$

Torque and breakaway torques:

Differential pressure				Δp in bar					
				0	2	4	6	8	10
				Δp in lbs					
				0	30	60	90	120	150
DN	perm. Torque MD _{max.} in Nm	req. Torque Md in Nm	Breakaway torque Mdi in Nm						
25 / 1"	142	7	10	13	13	13	13	13	18
50 / 2"	245	20	29	30	30	30	30	30	36
80 / 3"	657	50	74	74	78	81	85	85	104

Table 10 - Max. permissible torque and breakaway torque

The breakaway torques specified are average values which were measured with air at 20°C with the corresponding pressure differences. Operating temperature, process medium and long operating times may affect the permissible torques and breakaway torques considerably.

The listed max. permissible operating torques are valid for the standard materials in Table 4.

Selecting and sizing the rotary plug valve:

1. Calculate the appropriate Kv coefficient
2. Select the valve using Table 2, Table 3 and the Pressure-temperature diagram
3. Select a suitable actuator from Table 9
4. Additional equipment



Note: All details relevant for the order as well as versions different from those in the technical specifications can be taken from the corresponding order confirmation, if required.

Ordering text:

Rotary Plug Valve Series 23e,
DN / PN ,
optional special version

Manual gear actuator or
actuator (brand name):
Supply pressure: bar,
fail-safe position:

Limit switch (brand name):
Solenoid valve (brand name):
Positioner:
Others:

For your special requirements please contact our technical sales department

Pfeiffer Chemie-Armaturenbau GmbH

Hooghe Weg 41 • 47906 Kempen • Germany
Phone: +49 2152 2005 - 0 • Fax: +49 2152 1580

E-Mail: vertrieb@pfeiffer-armaturen.com • Internet: www.pfeiffer-armaturen.com

Specifications subject to change without notice