

Maintenance

Series 23a Rotary Plug Valve



Fig. 1 - Series 23a Rotary Plug Valve



The equipment may only be dismantled and disassembled by skilled staff who are familiar with the assembly, start-up, and operation of this product.

In these maintenance and assembly instructions, the term skilled staff refers to individuals who are able to judge the responsibilities assigned to them as well as recognize potential hazards due to their specialized training, knowledge, and experience as well as their special knowledge of the relevant standards.

1. Design, operation, and dimensions

Design, operation and dimensions as well as all further details and technical data can be found in **Data Sheet <TB 23a_EN>**.

2. Installation, start-up and maintenance

Instructions for the installation, start-up and maintenance are to be found in **Operating Instructions <BA 23a-01_EN>** for pneumatic rotary plug valves, **<BA 23a-02_EN>** for manually operated rotary plug valves.

0. Introduction

These instructions are intended to assist the user on assembling and repairing Series 23a Rotary Plug Valves.

Specifications are subject to change without notice. The text and drawings do not necessarily display the scope of supply or any ordering of spare parts. Drawings and graphics are not to scale.

Customer-specific designs not in accordance with our standard product range are not shown.

These instructions may only be passed on to third parties with written approval of Pfeiffer Chemie-Armaturenbau GmbH.

All documents are protected by German copyright laws. The transmission and/or duplication of documents, even excerpts, as well as the use and communication of their content is not permitted unless expressly granted.

Offenders will be liable for payment of damages. All rights to exercise industrial property rights are reserved.

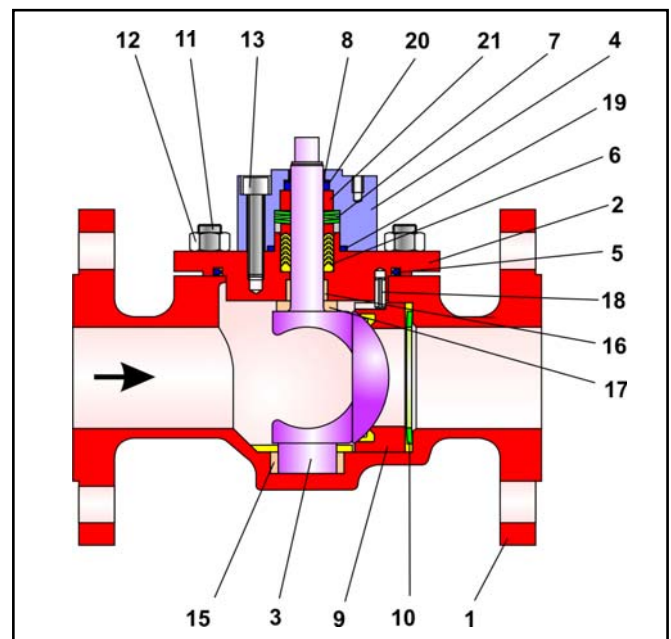

Fig. 2 - Sectional diagram of Series 23a Rotary Plug Valves => see Table 1 for list of parts

Rotary Plug Valve Series 23a

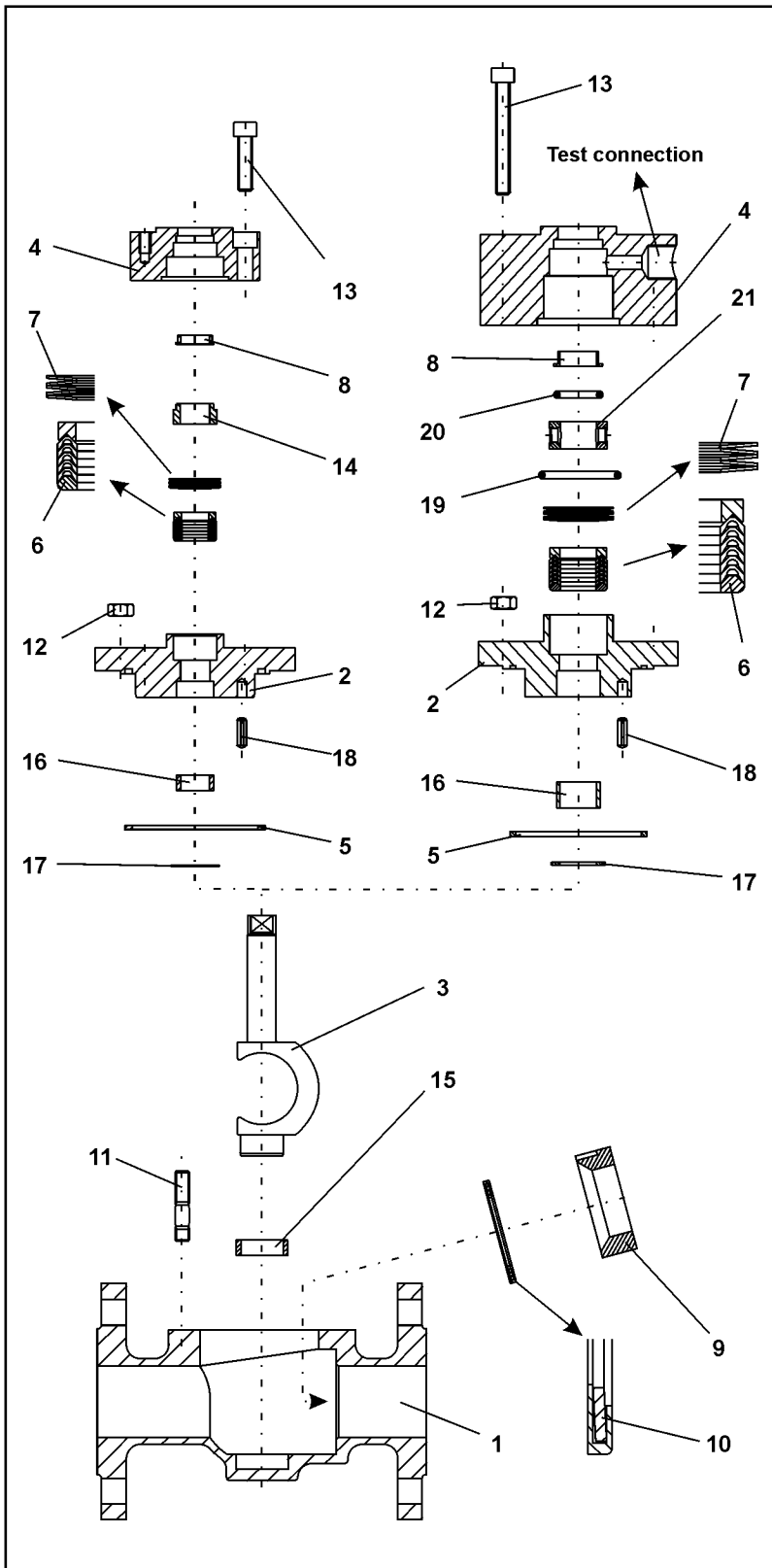

Fig. 3 - Exploded view of Series 23a Rotary Plug Valve

Item	Description	Material
1	Valve body	1.4581
2	Bonnet flange	1.4571
3	Rotary plug with stem	1.4581
4	Stuffing box flange	1.4571
5	Bonnet seal	PTFE / EPDM
6	V-ring packing	1.4305 / PTFE
7	Set of spring washers	1.8159 / Delta Tone
8	Bearing bushing	PTFE with carbon
9	Seat ring	1.4571 / TFM
10	Spring washer	1.4122 / PTFE
11	Stud bolt	A2-70
12	Nut	A2-70
13	Screw	A2-70
14	Distance bushing	PTFE with carbon
15	Bearing bushing	TFM
16	Bearing bushing	TFM
17	Distance washer	TFM
18	Grooved pin	1.4571
19	O-ring	FPM
20	O-ring	FPM
21	Distance bushing	1.4305

Table 1 - List of parts

3. Assembly of the rotary plug valve

3.1 Preparation for assembly

Before assembling the rotary plug valve, carefully clean all parts and place them on a soft surface (rubber mat or similar). Plastic parts are nearly always soft and very sensitive. Take particular care when handling the sealing surfaces to ensure that they do not get damaged.



Note! A high-performance grease paste is used during manufacturing to prevent the screws from cold welding in the bodies (e.g. Gleitmo 805 by Fuchs).

Do not use this lubricant with valves intended for oxygen service. Use a lubricant suitable for valves that are free of grease, especially for oxygen service.



Note! The position and arrangement of the individual parts shown in the detail drawing are to be observed during assembly.

3.2 Assembly of the valve body

Mount the valve body (1) in a vise with the bonnet flange bore facing upwards.



Note: Make sure that the flange is not damaged when mounted in the vise!

Press the bearing bushing (15) centrally into the body (1) using an offset plastic mandrel.

Screw stud bolts (11) into the body (1).

Insert the spring washers (10) from the top into the body (1) in the places intended for them. Refer to Fig. 3 for the location of the spring washers.



Note: A gasket can be used in place of the spring washer in certain versions.

Slide the seat ring (9) with its milled groove facing upwards into the body (1), ensuring it rests on the spring washer sealing.



Note: Older rotary plug valves do not have this groove, instead a circlip is used.

Insert the rotary plug (3) into the bearing bushing (15).



Note: Turn the rotary plug by hand to check whether the sealing matches the eccentricity.

Push the distance washer (17) over the plug stem onto the rotary plug.

Press the bearing bushing (16) into the bonnet flange (2).

Insert the grooved pin (18).

Insert the bonnet seal (5) into the appropriate groove in the bonnet flange (2).

Push the ready-assembled bonnet flange (2) over the plug stem onto the body and align it using the stud bolts.



Caution: The grooved pin (18) must engage in the groove of the seat ring (9).

Thread the nuts (12) onto the stud bolts and tighten evenly in a criss-cross pattern.



Note: Further assembly now depends on the version concerned.
First the **standard rotary plug valve**, and finally the rotary plug valve with **double stuffing box** is described.

3.3.1 Final assembly of the standard rotary plug valve version

Place the V-ring packing (6) turning the parts slightly over the plug stem into the packing chamber of the bonnet flange (2).

Refer to the Fig. 3 for arrangement of the packing rings.

Place the set of spring washers (7) on the V-ring packing. Refer to Fig. 3 for the arrangement of the set of spring washers.

Press the bearing bushing (8) into stuffing box flange (4) in the corresponding position.

Place the distance bushing (14) in the stuffing box flange. Push the ready-assembled stuffing box flange (4) over the ball stem onto the bonnet flange (2) and align it with the screws (13).

Tighten the screws evenly in a criss-cross pattern.

3.3.2 Final assembly of the ball valve with double stuffing box

Place the V-ring packing (6) turning the parts slightly over the plug stem into the packing chamber of the bonnet flange (2).

Refer to the Fig. 3 for arrangement of the packing rings.

Place the set of spring washers (7) on the V-ring packing. Refer to Fig. 3 for the arrangement of the set of spring washers.

Position the O-ring (19) on the bonnet flange.

Push the distance bushing (21) and the O-ring (20) over the ball stem and onto the spring washers.

Press the bearing bushing (8) into position in the stuffing box flange (4).

Carefully push the ready-assembled stuffing box flange (4) over the ball stem onto the bonnet flange (2) and align it with the screws (13).

Tighten the screws evenly in a criss-cross pattern.

Assembly of the rotary plug valve is now completed.

4. Troubleshooting

Refer to section 7 of **Operating Instructions**

< **BA 23a-01_EN** > for pneumatic rotary valves or

< **BA 23a-02_EN** > for manually operated rotary plug valves.

5. Repair of the rotary plug valve

5.1 Replacing the V-ring packing

If a leak is detected at the packing, the PTFE rings of the V-ring packing (6) may be defective. We recommend checking the condition of the packing.

To remove the packing, disassemble the valve in reverse order to that described in section 3. Check the PTFE rings of the packing and all plastic parts for damage. In case of doubt, replace the parts with new ones.

5.2 Replacing the seat ring and plug

If case of the valve does not shut-off properly, the seat ring (9) and the rotary plug (3) may be defective. We recommend checking the condition of these components.

To remove the seat ring and the rotary plug, disassemble the valve in reverse order to that described in section 3. Check the seat ring and the rotary plug are, together with all plastic parts for damage. In case of doubt, replace the parts with new ones.

5.3 Further repair work

In case of severe damage, we recommend the repair work to be carried out by Pfeiffer.

6. Customer inquiries

(Should you have any inquiries, please submit the following details:)

1. Order number (embossed on the valve body)
2. Type, product number, nominal size, and version of the valve
3. Pressure and temperature of the process medium
4. Flow rate in m³/h
5. Installation sketch, if possible

For your special requirements please contact our technical sales department.

Pfeiffer Chemie-Armaturenbau GmbH

Hooghe Weg 41 • 47906 Kempen • Germany

Phone: +49 2152 2005-0 • Fax: +49 2152 1580

E-Mail: vertrieb@pfeiffer-armaturen.com • Internet: www.pfeiffer-armaturen.com

Specifications subject to change without notice.