

# M-PTFE lined double-eccentric Series 10a Control and Shut-off Butterfly Valve

## Application:

Tight-closing, double-eccentric butterfly control valve with M-PTFE lining for process engineering and plants with industrial requirements, especially suitable for corrosive process media:

- Nominal sizes 4" to 32" and DN 100 to DN 800.
- Nominal pressure ANSI Class 150 and PN 10.
- Temperatures -58°F to 392°F (-50°C to 200°C).

The control equipment consists of a M-PTFE lined Butterfly valve and a pneumatic quarter-turn actuator or a hand-lever. The valves, which are of modular construction have the following features:

- Valve body made of
  - Spheroidal graphite iron A395 with the ANSI-version, or
  - EN-JS 1049 ( GGG 40.3 ) with the DIN-version.
- The valve body is lined with a 8 to 12mm thick isostatic M-PTFE lining.
- Body style
  - Wafer-Type or
  - Lug-Type
- Valve disc and valve shaft made of:
  - Stainless cast steel 1.4313, PTFE encapsulated.
- Further characteristics:
  - all parts in contact with media, are PTFE-lined,
  - excellent control characteristic even with small opening angles,
  - low breakaway torque and low amount of wear due to the double eccentric bearing design of the shaft,
  - suitable for vacuum operation.
  - Wafer type butterfly valve and Lug type butterfly valve can be mounted between flanges acc. to ANSI Class 150 or DIN PN10,
  - The disc can be exchanged without removing the shaft,
  - "TA - Luft" (German clean air act) and VDI 2440,
  - Face-to-face dimensions acc. to DIN EN 558 Series 16 (K3 acc. to DIN 3202),
  - Attachment options acc. to DIN ISO 5211.



Fig.1 - Series 10a Wafer-Type Butterfly valve with Series 31a AT-Actuator

Fig 2 - The screwed-in, lined disc (Lug-type) series 10a with a disc made from titan (3.7035) and with a AT-Actuator, series 31a

# Butterfly Valve Series 10a

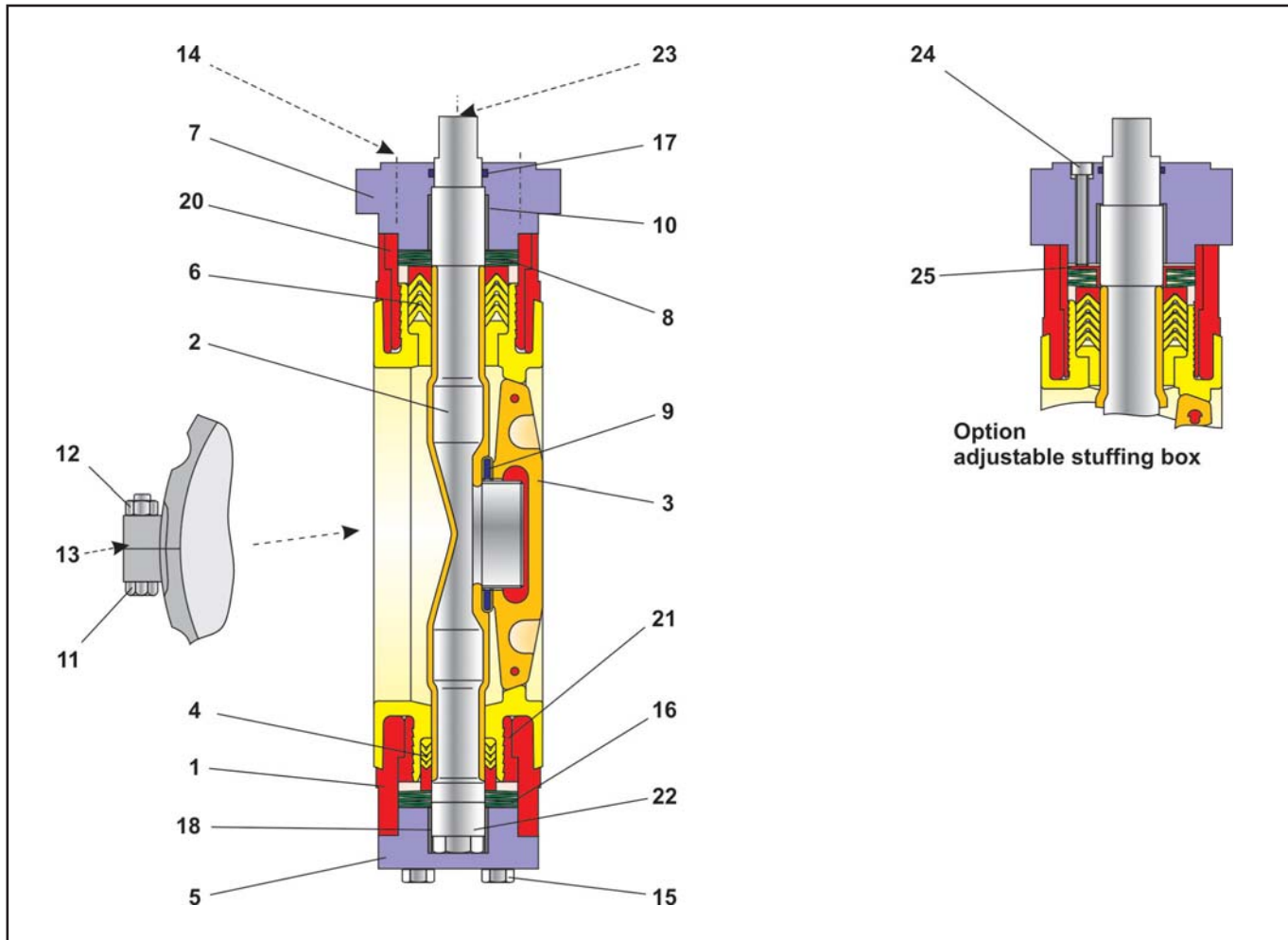

Fig. 3 - PTFE lined Butterfly valve

Item	Description
1	Valve body
2	Valve shaft
3	Valve disc
4	V-ring packing
5	Lower gland flange
6	V-ring packing
7	Guide bushing
8	Set of Belleville washers
9	Sealing element
10	Bushing
11	Screw
12	Nut

Item	Description
13	Grooved pin
14	Screw
15	Screw
16	Set of Belleville washers
17	O-ring
18	Bushing
20	Bushing
21	Bushing
22	Bearing screw
23	Threaded pin
24	Screw
25	Bushing

Table 1 - List of parts

### Versions:

M-PTFE lined butterfly control valve in the following versions:

- Butterfly valve with manual gear actuator.
- Shut-off valve with Series 31a pneumatic rotary actuator.
- Throttling valve preferably with Series 30a pneumatic diaphragm actuator

### Special version:

- Electric rotary actuator
- Linings with special PTFE compounds, e.g. electro conductive.
- Special stem seals for high vacuum,
- Disc components made of special materials, e.g. titanium, hastelloy

### Additional accessories and attachments:

The following accessories for the control valve are obtainable either single or in combination:

- Positioner
- Limit switch
- Solenoid valve
- Air supply station
- Pressure gauge mounting blocks

Further attachment parts are possible on request, according to specifications .

### Function and operation:

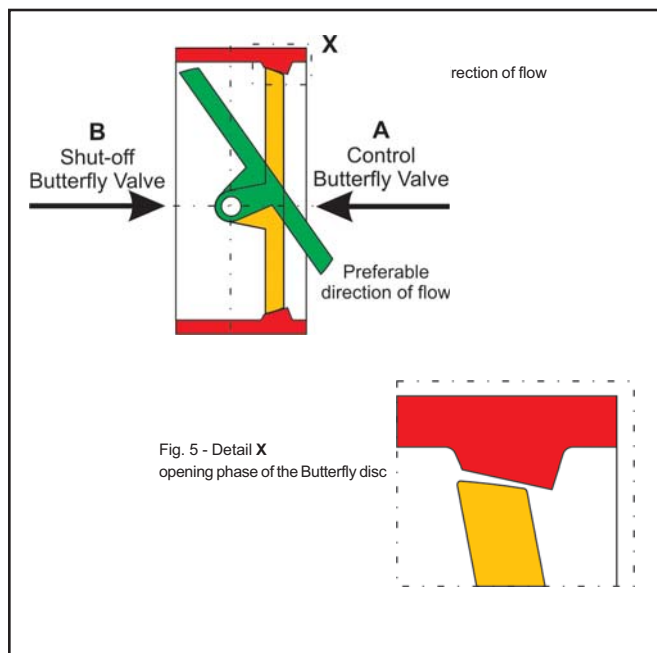

The process medium can flow through the butterfly valve in both directions.

The butterfly disc ( 3 ) determines the flow through the free area between disc and seat.

The shaft ( 2 ) is sealed at both ends by a V-ring packing ( 4 and 6 ). With the spring washers ( 8 and 16 ) located at the top of packing chamber, the packing is maintenance free and pre-loaded.

Butterfly valves are sealed between the butterfly disc ( 3 ) and the seat.

The direction of flow, and the differential pressure determine the breakaway torque to open the butterfly valve.

The double eccentric bearing of the disc shaft, causes the disc to remain in contact with the seat only through a very small angle when opening and closing. ( Fig. 5 ).

This reduces wear and increases the service life of the valve. In addition, the breakaway torque is reduced.

When the process medium flows through the valve in direction **A** ( Fig. 4 ), the butterfly disc is slightly lifted out of the seat. This reduces the pre-loading and the breakaway torque.

When the process medium flows through the valve in direction **B**, the pre-load forced rises, with a subsequent increase in the breakaway torque.



**Failure position:** Depending on the pneumatic actuator, the butterfly valve has two safety positions, which become effective when pressure is relieved, or when the air supply fails:

- **Butterfly valve with actuator “ Spring closes “**  
When the air supply fails, the valve closes.  
The valve opens when the air control pressure increases acting against the force of the springs.
- **Butterfly valve with actuator “ Spring opens “**  
When the air supply fails, the valve opens.  
The valve closes when the air control pressure increases against the force of the springs.



**Note:** Before using the butterfly valve in hazardous areas, check whether this is possible according to ATEX 94/9/EC.  
See operating Instructions <BA 10a>.

# Butterfly Valve Series 10a

## Technical data:

Nominal size	4" to 32" and DN 100 to DN 800	
Nominal pressure	ANSI Class 150 and PN 10	
Body style	Lug-type and wafer-type	
End connection	can be mounted between ANSI 150lbs and PN10	
Temperature range	see pressure-temperature diagram	
Leakage for	Flow direction A	On request, depending on pressure and temperature
	Flow direction B	Leakage rate A acc. to DIN EN 12266-1, P1 (Class VI acc. to ANSI / FCI 70-2-1976)
Rangeability	50 : 1	
Face-to-face dimensions	DIN	DIN EN 558-1, series 16 ( DIN 3202, K3 )
	ANSI	DIN EN 558-2, series 16 (ISO 5752, series 16)
Perm. operating pressure	see pressure-temperature diagram	
External leakage tightness	$< 10^{-6}$ mbar l/sec	

Table 2 - technical data

## Materials:

Version	DIN	ANSI
Body	EN-JS 1049 ( GGG 40.3 )	A 395
Lining	M-PTFE	ASTM D 4894 Typ III-2
Butterfly disc	1.4313 with PTFE coating	1.4313 with ASTM D 4894 Typ IV-2
Shaft	1.4313 with M-PTFE coating	1.4313 with ASTM D 4894 Typ III-2
Packing	PTFE V-ring packing loaded by Belleville washers (1.8159)	
Bearing bushing	PTFE with carbon	
Coating	2-Components-Pur-Varnish Colour: Black, RAL 9005	

Table 3 - Materials

## Terms for noise level calculation:

$\varphi$	10°	20°	30°	40°	50°	60°	70°	80°	90°
FL	0.95	0.95	0.92	0.82	0.74	0.67	0.61	0.57	0.54
xT	0.75	0.75	0.73	0.57	0.47	0.38	0.31	0.28	0.25
Z	0.35	0.30	0.25	0.20	0.17	0.15	0.13	0.12	0.11

Table 4 - noise level calculation and terms for control valve sizing

z-values for noise level calculation acc. to VDMA 24422 and terms for control valve sizing acc. to DIN EN 60534 opening angle.

## Correction terms:

with liquids  $\Delta LF = 0$ ,  
with gases and vapors  $\Delta LG = 0$

**Characteristic curve:**

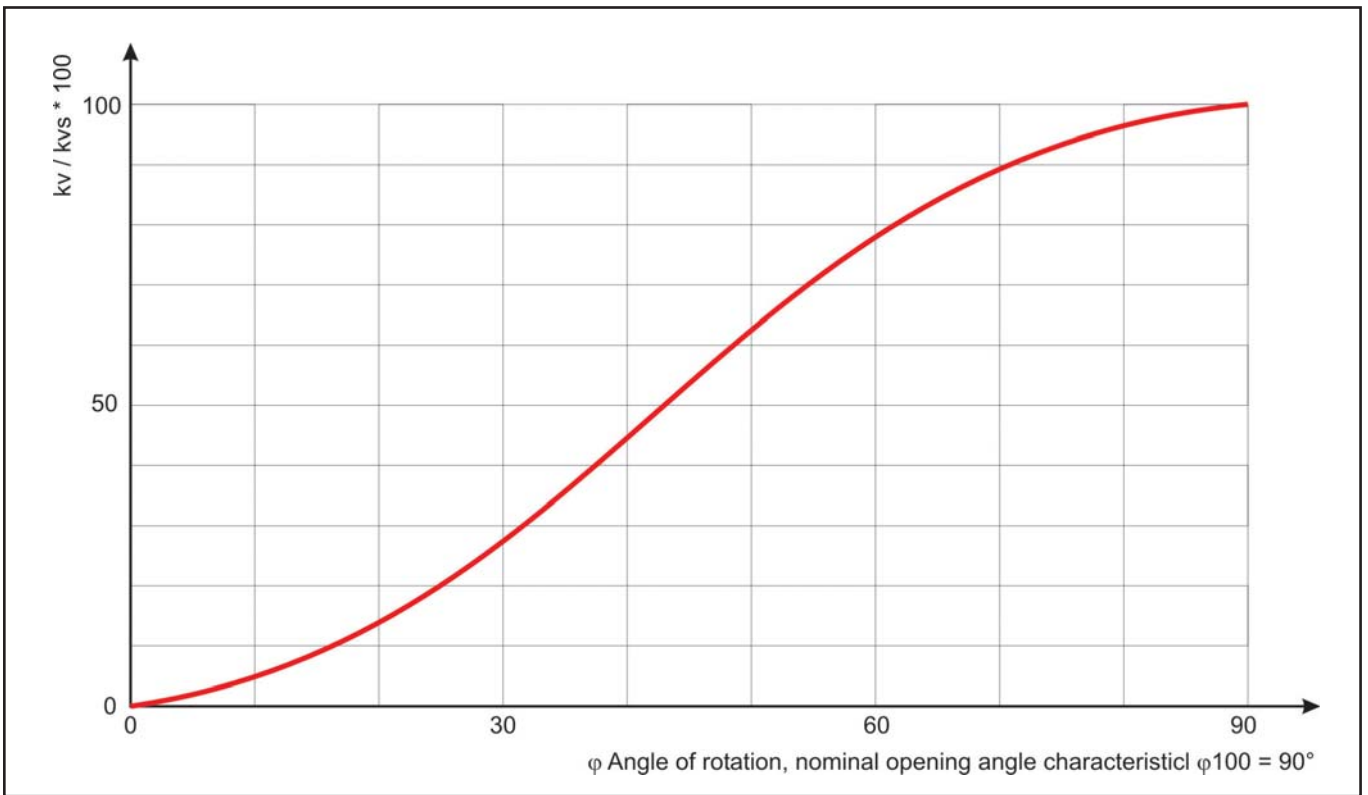

Fig. 6 – Characteristic curve

**kv - values and associated opening angles:**

DN	φ Opening angle								
	10°	20°	30°	40°	50°	60°	70°	80°	90°
100 / 4"	7	24	48	79	120	161	211	232	240
150 / 6"	21	70	140	231	350	469	616	679	700
200 / 8"	42	139	278	459	695	931	1223	1348	1390
250 / 10"	68	227	454	749	1135	1520	1998	2200	2270
300 / 12"	100	334	668	1102	1670	2238	2939	3240	3340
350 / 14"	142	472	944	1558	2360	3163	4154	4579	4720
400 / 16"	183	610	1220	2013	3050	4087	5368	5917	6100
500 / 20"	288	962	1924	3175	4810	6445	8465	9331	9620
600 / 24"	415	1385	2771	4572	6926	9281	12177	13473	13853
800 / 32"	737	2463	4925	8128	12314	16499	21674	23887	24627

Table 5 – kv-values

**Cv - values and associated opening angles:**

DN	φ Opening angle								
	10°	20°	30°	40°	50°	60°	70°	80°	90°
100 / 4"	8	28	56	92	140	188	247	271	281
150 / 6"	25	82	164	270	409	549	721	794	819
200 / 8"	49	163	325	537	813	1089	1431	1577	1626
250 / 10"	80	266	531	876	1328	1778	2338	2574	2656
300 / 12"	117	391	782	1289	1954	2618	3439	3791	3908
350 / 14"	166	552	1359	1823	2761	3701	4860	5357	5522
400 / 16"	214	714	1427	2355	3568	4782	6281	6923	7137
500 / 20"	337	1126	2251	3715	5628	7541	9904	10917	11255
600 / 24"	486	1620	3242	5349	8103	10859	14247	15763	16208
800 / 32"	862	2882	5762	9510	14407	19304	25358	27948	28814

Table 6 – Cv-values

# Butterfly Valve Series 10a

## Pressure-Temperature diagram:

The area of application is determined by the pressure-temperature diagram. Process data and the process medium can affect the values in the diagram.

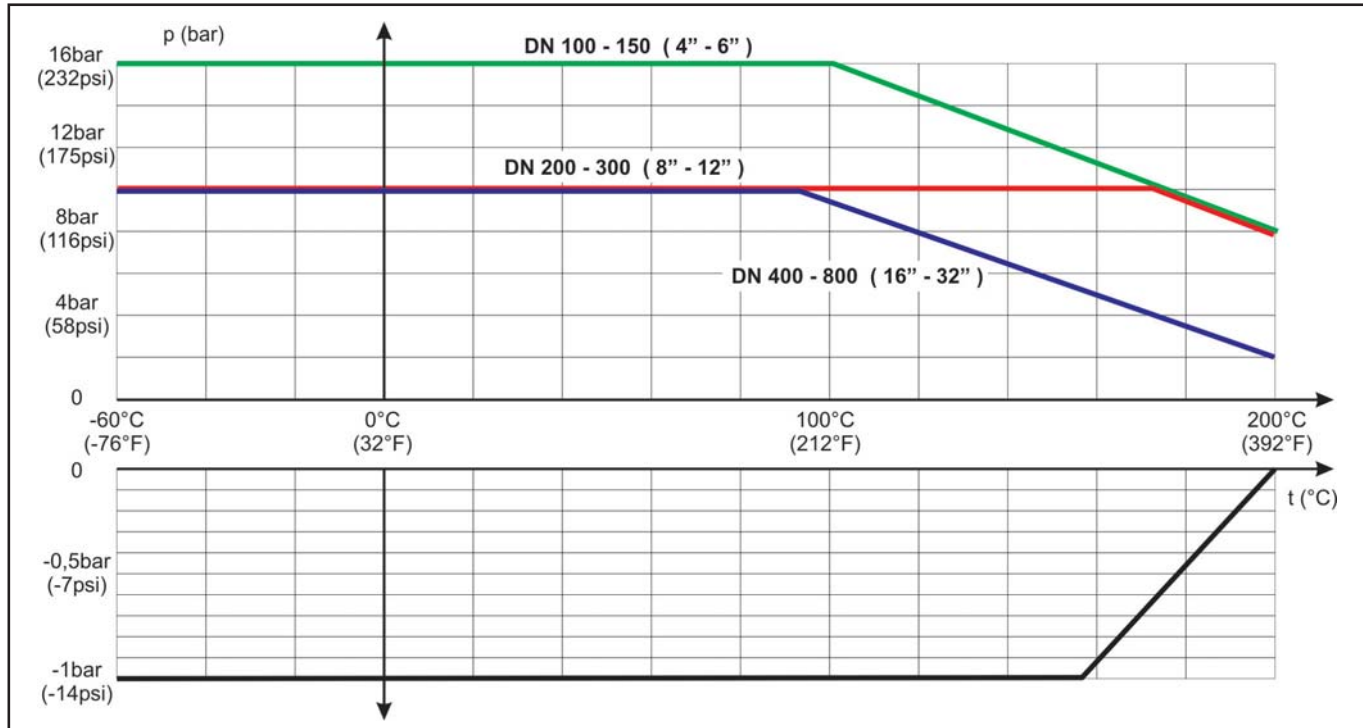

Fig. 7 - Pressure-Temperature diagram

## Functional diagram with opening angles:

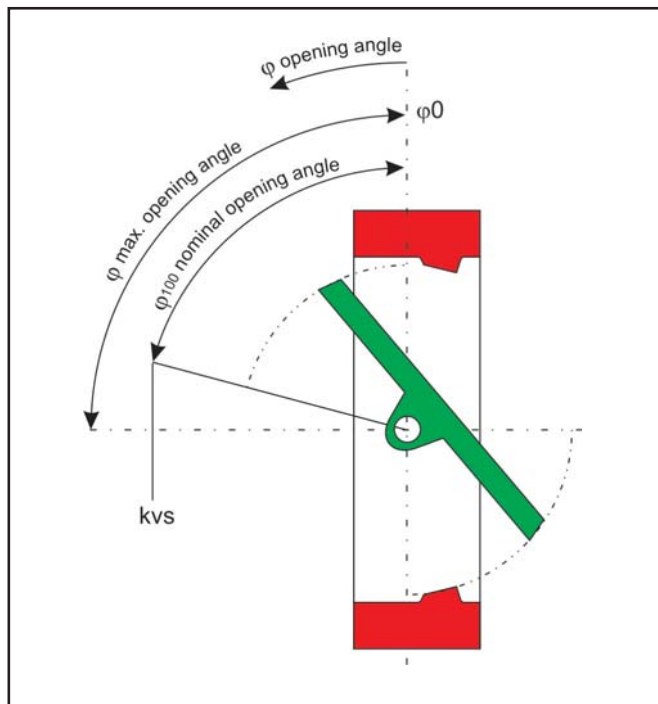

Fig. 8 - Functional diagram with opening angles

## Torque and breakaway torques:

DN	Torque MDmax. in Nm	perm. differential pressure $\Delta p$ with direction of flow				
		A		B		
		0 bar (0 psi)	1 bar (15 psi)	2 bar (29 psi)	3 bar (44 psi)	5 bar (73 psi)
		Breakaway torque Mdl in Nm				
100 / 4"	225	40	40	44	48	55
150 / 6"	490	120	135	160	180	205
200 / 8"	988	190	220	250	280	340
250 / 10"	1930	350	480	640	700	820
300 / 12"	3066	500	600	700	800	
350 / 14"	4365	840	870	on request		
400 / 16"	4576	800	870			
500 / 20"	8938	924	1280			
600 / 24"	15444	1300	1700			
800 / 32"	33930	1700	2200			

Table 7 - max. permissible torque, required torque and breakaway torque

The specified breakaway torques are average values which were measured with air at 20°C with the corresponding differential pressures. Operating temperature, process medium and long operating periods may affect the permissible torques and breakaway torques considerably. The maximum permissible torques listed apply to the standard materials specified in table 3.

### Dimensions and weights:

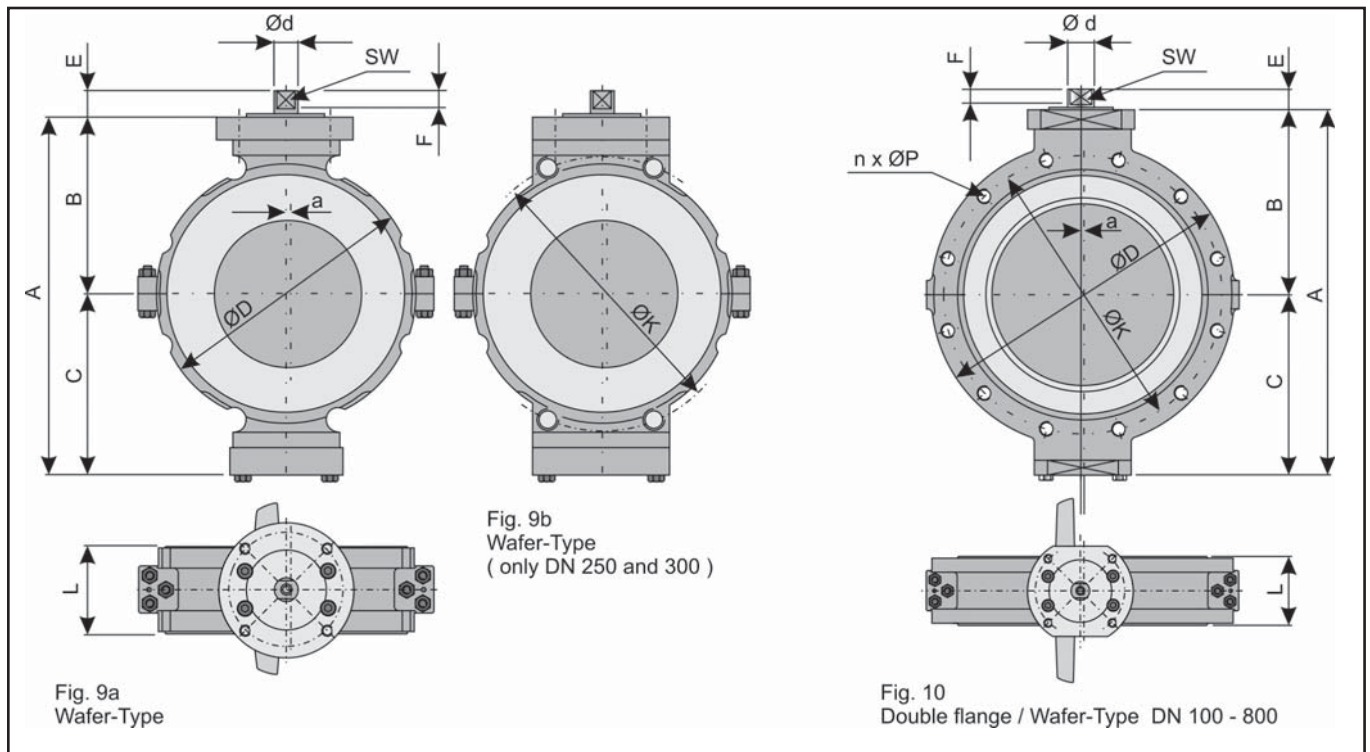

DN	100 / 4"	150 / 6"	200 / 8"	250 / 10"	300 / 12"	350 / 14"	400 / 16"	500 / 20"	600 / 24"	800 / 32"	
L	PN 10	64	76	89	114	114	127	140	152	178	241
	Class150	64	76	89	114	114	127	140	152	178	241
A		246	319	404	494	571	617	673	821	971	1214
B		134	166	209	268	291	312	349	430	493	603
C		112	153	195	226	280	305	324	391	478	611
a		1,5	1,5	2	2,5	3	3	3	3	5	6
ØD	Wafer-Type	164	228	283	340	388	524	588	687	780	1015
	Lug-Type	206	270	331	386	445	-	565	687	780	1015
ØK	PN 10	180	240	295	350	400	460	515	620	725	950
	Class150	190.5	241.3	298.5	362	431.8	476.3	539.8	635	749.3	900
n x ØP Wafer-Type	PN 10	8x 18	8x 22	8x 22	12x 22	12x 22	16x 22	16x 26	20x 26	20x 30	24x 33
	Class150	8x 19.1	8x 22.4	8x 22.4	12x 25.4	12x 25.4	12x 28.4	16x 28.4	20x 31.8	20x 35.1	48x 22.4
n x p Lug-Type	PN 10	8x M16	8x M20	8x M20	12x M20	12x M20	16x M20	16x M24	20x M24	20x M27	24x M30
	Class150	8x UNC 5/8"	8x UNC 3/4"	8x UNC 3/4"	12x UNC 7/8"	12x UNC 7/8"	12x UN 1"	16x UN 1"	20x UN 1 1/8"	20x UN 1 1/4"	*
E		19	23	27	31	31	31	41	39	54	65
F		12	16	20	24	24	24	32	30	45	56
Ø d		20	21	28	36	41	41	45	57	65	90
SW		12	16	20	24	24	24	32	34	45	56
DIN ISO Connection		F05	F10	F12	F14	F14	F14	F16	F16	F25	F25
Weight in kg		7	16	24	40	55	76	100	170	277	463

Table 8 - Dimensions in mm and weights in kg

**Selecting and sizing the butterfly valve:**

1. Calculate the appropriate kv value.
2. Select the nominal diameter and the kvs value (Cv value ) from table 7 ( table 8 ).
3. Check the operation conditions in acc. to the pressure-temperature diagram.
4. Select a suitable actuator.



**Note:** All relevant details regarding the version ordered, which deviate from the specified version in this technical description data, can be taken if required, from the corresponding order confirm.

**Ordering text:**

PTFE-lined control/shut-off butterfly valve Series 10a,  
DN . . . .  
PN . . . .  
optional special version

Manual gear actuator or actuator (manufacturer): . . . .  
Supply pressure: . . . . bar,  
fail-safe position: . . . .

Limit switch (manufacturer): . . . .  
Solenoid valve (manufacturer): . . . .  
Positioner: . . . .

Others: . . . .

**For your special requirements please contact our technical sales department.**

**Pfeiffer Chemie-Armaturenbau GmbH**

Hooghe Weg 41 • 47906 Kempen  
Telefon: 02152 / 2005-0 • Telefax: 02152 / 1580  
E-Mail: [vertrieb@pfeiffer-armaturen.com](mailto:vertrieb@pfeiffer-armaturen.com) • Internet: [www.pfeiffer-armaturen.com](http://www.pfeiffer-armaturen.com)

**Specifications and designs are subject to change without notice.**