

# PTFE - Angle Valve Series 8a

## Application:

PTFE-lined control valve for severely aggressive or corrosive media, especially für chemical processes:

- Nominal sizes 1/2" to 2" as well as DN 15 to DN 50
- Nominal pressure PN 10/16
- Temperatures up to 150°C

The angle valve consists of a valve body with PTFE-lining and either a pneumatic actuator or hand operated actuator. The valve is designed according to the modular-assembly principle and can be combined with various options and has the following features:

- Valve body of PTFE and a reinforcing casting of ductile iron with a plastic coating.
- Exchangeable PTFE seat and PTFE plug.
- Stem sealed by a PTFE bellows and a backup spring-loaded PTFE V-ring packing.
- Test connection for monitoring of the primary bellow seal.
- Exchangeable actuator.
- Additional equipment can be added in acc. to DIN EN 60534 and Namur recommendations.
- Face-to-face dimensions acc. to DIN EN 558-1, Series 8.

## Versions:

The Series 8a Angle Valve is available optionally in the following versions:

- Samson actuator (Fig. 1).
- Samson hand-operated actuator.
- Actuators of other manufacturers on request.

## Special designs:

- Further nominal diameters available on request.
- Lining made of special compound, e.g. conductive PTFE.
- Valve plug and seat made of special materials (e.g. tantalum or aluminium oxide) for erosive media.
- Guided V-port plug.

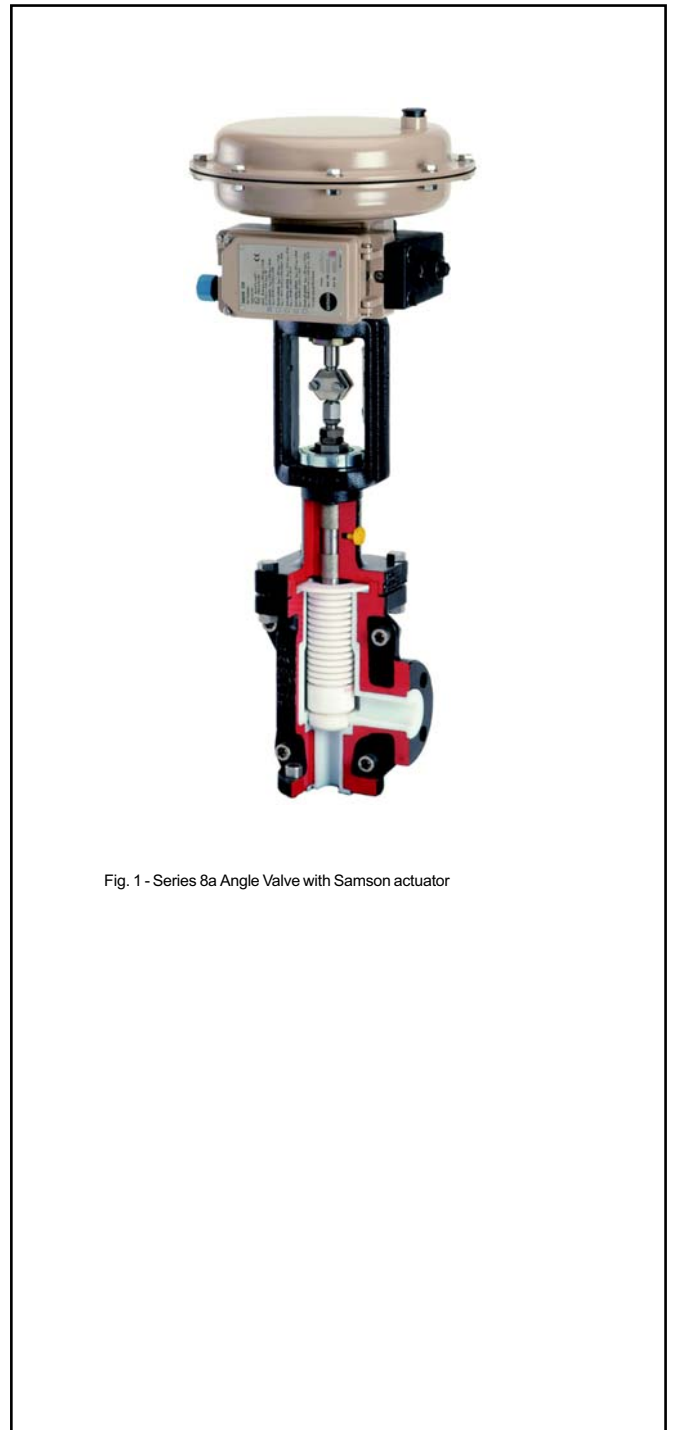

Fig. 1 - Series 8a Angle Valve with Samson actuator

# Angle Valve Series 8a

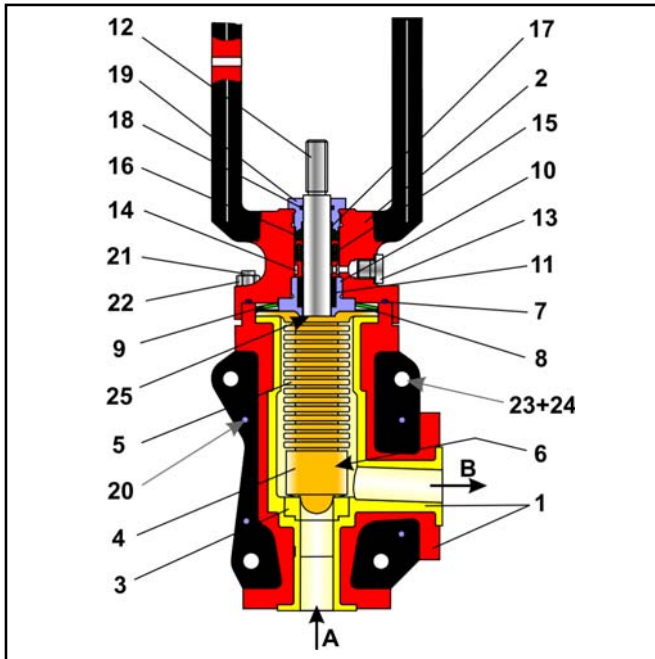

Fig. 2 - Sectional diagram of Series 8a Angle Valve

Item	Description	Item	Description
1	PTFE body with steel casing	14	Distance bushing
2	Bonnet flange	15	V-ring packing
3	Seat	16	Set of Belleville washers
4	Plug	17	Bearing bushing
5	Bellows	18	O-ring
6	Cord	19	Stuffing box
7	O-ring	20	Grooved pin
8	Thrust washer	21	Stud
9	Disc spring	22	Nut
10	Guide bushing	23	Screw
11	Bushing	24	Nut
12	Stem connector	25	Retainer ring
13	Locking screw		

Table 1 - List of parts

## Principle of operation:

The process medium flows through the Series 8a Angle Valve in the flow-to-open direction. The valve plug position determines the cross-sectional area of flow between the seat ( 3 ) and the plug ( 4 ).

The plug is connected over the stem connector ( 12 ) to the actuator stem. The PTFE bellows ( 5 ) seals the area between the valve body ( 1 ) and stem connector ( 12 ). The PTFE V-ring packing ( 15 ) is used as a backup stem sealing.

A test connection port ( 13 ) allows the bellow to be monitored for leakage, e.g. by connecting a suction line or inert gas line.

The plug ( 4 ) is easily exchanged thanks to its tongue and groove connection to the PTFE bellows which is secured by a strong PTFE cord ( 6 ).

The PTFE seat ( 3 ) is screwed into the valve body ( 1 ) over a thread suitable for plastic.



**Note :** In the event that cavitation may occur, we recommend the use of a guided plug for differential pressures over 3 bars and differential pressure ratio  $p_2 < \Delta p$ , !



**Note:** Before using the valve in hazardous areas, check whether this is possible according to ATEX 94/9/EG by referring to the Operating Instructions < BA 01a >.



**Fail-safe position:** Depending on how the pneumatic actuator is mounted to the valve, the valve has two fail-safe positions which become effective when the air pressure in the actuator is relieved or when the supply air fails:

- **Control valve with actuator “ Spring closes “**  
Upon air failure, the valve is closed. The valve opens when the signal pressure increases, acting against the force of the springs.
- **Control valve with actuator “ Spring opens “**  
Upon air failure, the valve is opened. The valve closes when the signal pressure increases, acting against the force of the springs.

## Additional equipment and add-on pieces:

For the control valves, the following accessories are available either individually or in combination:

- Positioner
- Limit switch
- Solenoid valves
- Supply air pressure regulator/filter
- Pressure gauge mounting blocks

Further accessories are available on request for customer specifications.

## Pressure - Temperature - Diagram:

The range of application is determined by the pressure-temperature diagram. Process data and medium can affect the values of the diagram.

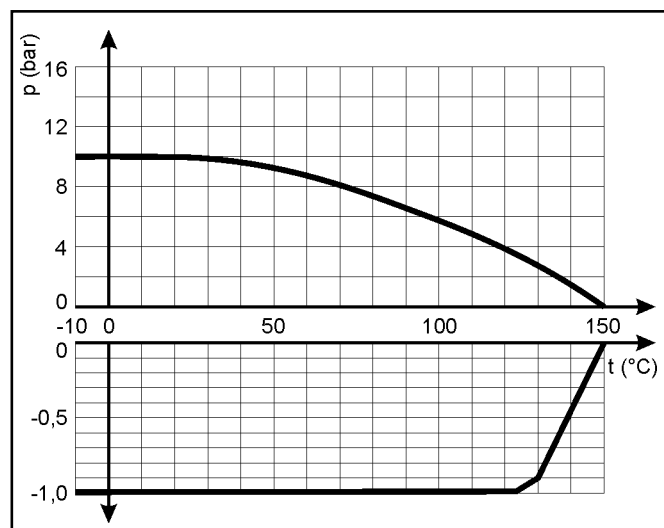

Fig. 3 - pressure-temperature diagram

### Technical Data:

Nominal size	DN 15 to DN 50 as well as 1/2" to 2"
Nominal pressure	PN 10 / 16
Temperature range	see pressure-temperature diagram
Characteristic	Equal percentage / linear
Leakage rate	Leakage rate A acc. to DIN EN 12266-1, P12 (Leakage rate 1 BO acc. to DIN 3230 Part 3)
Rangeability	30 : 1
End connections	as per DIN EN 1092-2, Form B resp. ANSI 150 lbs

Table 2 - technical data

### Materials:

Body and bonnet flange	Pure - PTFE or PTFE with 10% or with 25% carbon
Casing	EN-JS 1049 (GGG 40.3) / 1.0570
Valve plug and seat	PTFE <sup>1)</sup> optionally Al <sub>2</sub> O <sub>3</sub> , Tantalum or other metals
Bellows	PTFE
Bearing bushing	Glycodur
Packing	PTFE V-ring packing loaded by Belleville washers (1.8159)
O - ring	Viton
Plug stem	1.4571 / 1.4301
Coating	2-Components-Pur-Varnish Colour: Black (RAL 9005)

Table 3 - Materials

<sup>1)</sup> when seat diameter 2mm, only tantalum or other metals

### z values depending on kvs value and nominal size:

DN		15 1/2"			25 1"			40 1 1/2"	50 2"	
Seat-ø in mm		2 <sup>2)</sup>	6	10	2 <sup>2)</sup>	6	13	24	30	38
Travel in mm		10	15		10	15				
kvs	Cv	Acoustical valve coefficient z								
0.005	0.006	0.9								
0.01 0.05	0.01 0.06	0.85			0.85					
0.1 0.25 0.63 1.0	0.12 0.29 0.74 1.17		0.65			0.65				
1.6 2.5	1.9 2.9			0.6			0.6			
4	4.7						0.55		0.55	
6.3	7.4							0.45	0.5	0.5
10	12							0.4	0.45	0.45
16	19								0.4	0.4
25	29									0.35

Table 4 - Acoustical valve coefficient z in accordance with VDMA 24422

<sup>2)</sup> when seat diameter 2 mm, only linear characteristic line available.



**Note:** Trims with guided plugs partly have reduced kvs value

### Terms for noise level calculation:

according to VDMA 24422.  
z = acoustical valve coefficient.

### Terms for control valve sizing:

according to DIN EN 60534-2-1:  
**FL = 0,96    xT = 0,75**

### Correction terms:

For gases and vapours :  $\Delta L_G = 0$ ,  
For liquids:  $\Delta L_F = 0$

### Permissible differential pressures $\Delta p$ :

Signal pressure range				0.2-1.0	0.3-1.1	0.4-1.2	0.4-2.0	0.6-2.2	0.2-1.0		
Required supply pressure				1.3	1.4	1.4	2.3	2.5	1.2	1.4	1.6
DN	Inch	Seat ø in mm	Actuator in cm <sup>2</sup>	$\Delta p$ bei p <sub>2</sub> = 0							
15 - 25	1/2" - 1"	2	240	> 16	-	-	-	-	> 16	-	-
		6	240	> 16	-	-	-	-	> 16	-	-
		10	240	> 16	> 16	-	-	-	> 16	-	-
25	1"	13	240	8	> 16	-	> 16	-	8	> 16	-
		24	240	-	3.5	-	7.6	15.8	-	7.6	15.8
			350	3.2	-	15.2	15.2	-	3.2	15.2	-
40	1 1/2"	30	240	-	1.1	-	3.9	9.3	-	3.9	9.3
			350	0.9	-	8.9	8.9	> 16	0.9	8.9	-
50	2"	38	240	-	-	-	1.5	4.9	-	1.5	4.9
			350	-	-	4.7	4.7	9.7	-	4.7	9.7

Table 5a - Valves with spring closing actuator. Valve with signal pressure 0 bar closed.

Table 5b - Valves with spring opening actuator. Valve with required signal pressure closed.

The shaded columns of the table show the standard values. The differential pressures in the white columns of table 5a apply to max. pre-loaded springs. The permissible differential pressures quoted are only valid for soft-sealing valves.

## Dimensions and weights:

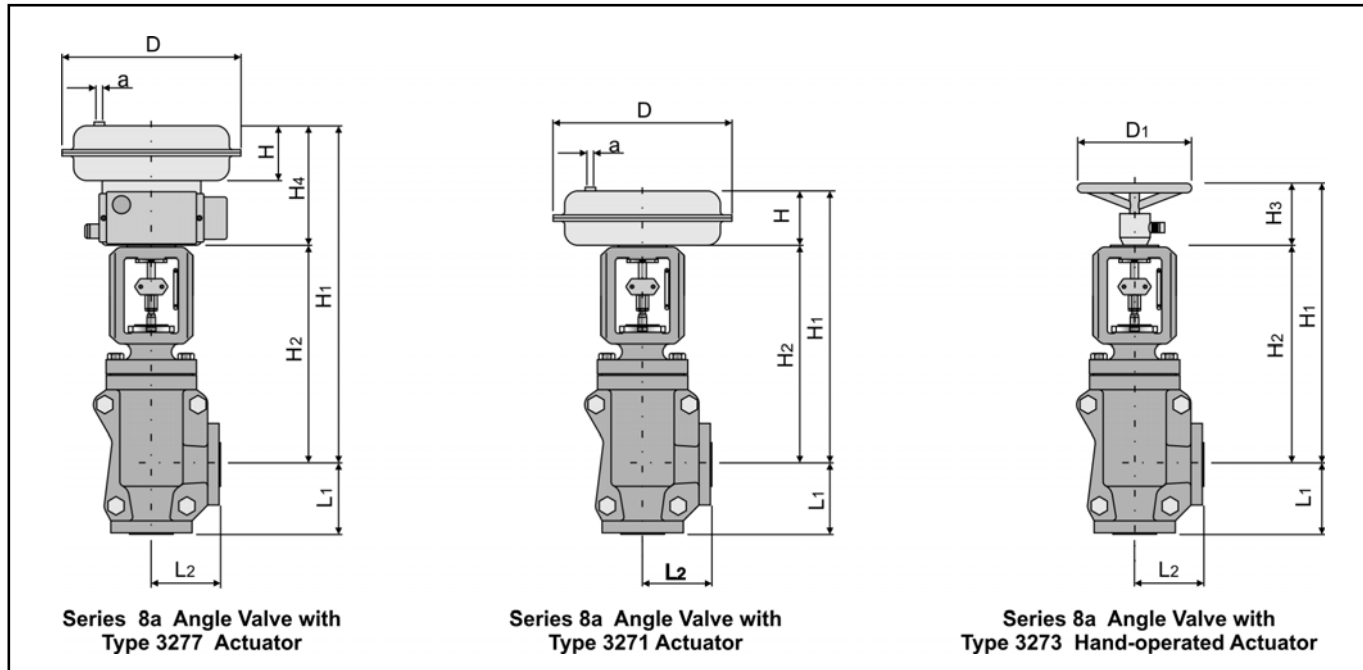

Fig. 4 - Dimensional drawing

DN	15 / 1/2"	25 / 1"	40 / 1 1/2"	50 / 2"												
L1	90	99	111	127												
L2	90	89	102	127												
H1	<table border="0"> <tr> <td>Samson Type 3271</td> <td colspan="3">H2 + H</td> </tr> <tr> <td>Samson Type 3277</td> <td colspan="3">H2 + H4</td> </tr> <tr> <td>Samson Type 3273</td> <td colspan="3">H2 + H3</td> </tr> </table>				Samson Type 3271	H2 + H			Samson Type 3277	H2 + H4			Samson Type 3273	H2 + H3		
Samson Type 3271	H2 + H															
Samson Type 3277	H2 + H4															
Samson Type 3273	H2 + H3															
H2	247,5	345	317	469												
Weight, Valve in kg	10	14	18	21												
Actuator	<table border="0"> <tr> <td>240 ccm</td> <td>x</td> <td>x</td> <td>x</td> <td>x</td> </tr> <tr> <td>350 ccm</td> <td></td> <td>x</td> <td>x</td> <td>x</td> </tr> </table>				240 ccm	x	x	x	x	350 ccm		x	x	x		
240 ccm	x	x	x	x												
350 ccm		x	x	x												
D1	180	180	180	180												
H3	92	92	92	92												
Weight, Type 3273 in kg	2	2	2	2												

Actuator in ccm	240	350
D	240	280
H	65	85
H4	166	186
a	G 1/4"	G 3/8"
Weight, Type 3271 in kg	5	8
Weight, Type 3277 in kg	9	12

Table 6 - Dimensions in mm and weights in kg

### Selection and sizing of the control valve:

1. Calculate the appropriate Kvs acc. DIN EN 60534-2-1
2. Select valve size and Kvs over Table 4.
3. Determine the differential pressure and select the suitable actuator over Tables 5a and 5b.
4. Check the application against the pressure-temperature diagram.
5. Select additional equipment.

### Order text:

Series 8a Angle valve, DN....., PN....., kvs .....

Basic characteristic curve: equal percentage / linear

Body: EN-JS 1049 / PTFE-white, Flange design: Form C / F - groove

Special design

Actuator: Samson Type..... cm<sup>2</sup>, Control pressure range : ..... bar,

Connection of a positioner, a limit switch and/or a solenoid valve



**Note:** All relevant details regarding the version ordered, which deviate from the specified version in this technical description data, can be taken if required, from the corresponding order confirm.

For your special requirements please contact our technical sales department.

## Pfeiffer Chemie-Armaturenbau GmbH

Hooghe Weg 41 • 47906 Kempen • Germany

Telefon: +49 2152 2005 - 0 • Telefax: +49 2152 1580

E-Mail: [vertrieb@pfeiffer-armaturen.com](mailto:vertrieb@pfeiffer-armaturen.com) • Internet: [www.pfeiffer-armaturen.com](http://www.pfeiffer-armaturen.com)

Values subject to change