

double-eccentric Control and Shut-off Butterfly Valve Series 14a

Application:

Tight-closing, double-eccentric butterfly control valve produced from anti-corrossive material especially for the chemical industry where aggressive media's are used, for example in steam pipelines:

- Nominal sizes DN 80 to DN 500 as well as 3" to 20",
- Nominal presure PN 10 as well as ANSI 150 lbs,
- Temperatures -10°C to 200°C

The control equipment consists of a stainless steel butterfly valve and a pneumatic rotary actuator or a manual actuator. The valves designed in the modular principle can be combined with various accessories and are equipped with the following special features:

- Valve body, valve shaft and valve disc made of special material.
- Low breakaway torque and low amount of wear due to the double eccentric bearing design of the shaft.
- Valve shaft sealing through live-loadet PTFE V-ring packing.
- Anti blow out valve shaft.
- Tighter sealing through various exchangeable seat rings.
- Attachment options acc. to DIN ISO 5211.
- Face-to-face acc. to DIN EN 558-1 or DIN EN 558-2, basic series 16.

Versions:

Butterfly control valve Series optionally available in the following versions:

- Hand lever / grid plate.
- Manual gear actuator.
- Pneumatic rotary actuator Series 31a.
- Pneumatic diaphragm rotary actuator Series 30a.

Special versions:

- Special materials, e.g. nickel, hastelloy, monel, titanium.
- Nominal size > DN 500 on request.
- Safety stem seal.
- Primary seal.
- Groove in raised face.
- Metal seat rings.
- Low temperature version.
- High temperature version.



Fig. 1 - tight shut-off butterfly valve series 14a



Fig. 2 - tight shut-off butterfly valve series 14a with gear actuator

Butterfly Valve Series 14a

Additional accessories:

The control valves are also available without any accessories or in combination with the following parts:

- Positioner
- Limit switch
- Solenoid valve
- Air sets
- Gauge block

Other special accessories are available on request.

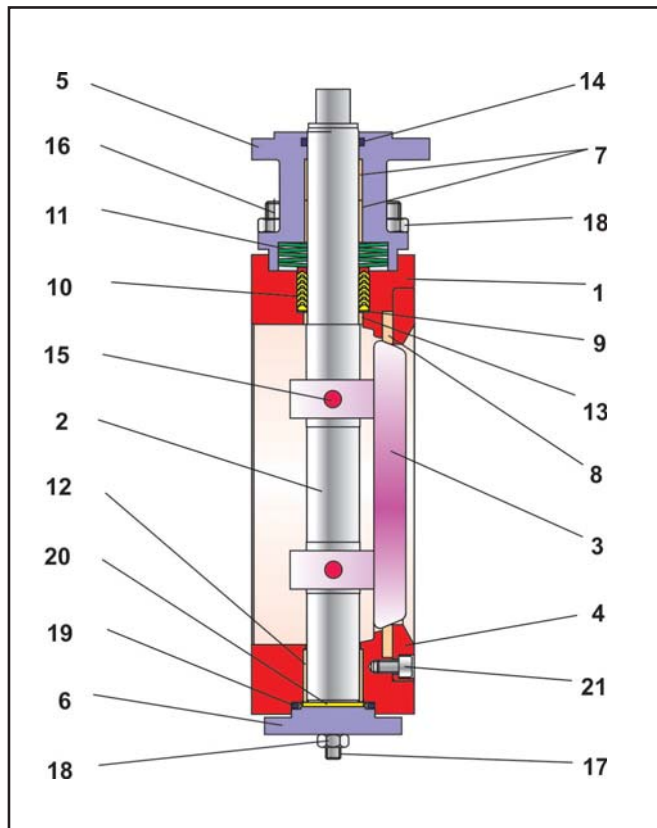

Fig. 3 - butterfly valve series 14a

Pos.	Description	Pos.	Description
1	Valve body	12	Bushing
2	Valve shaft	13	Bushing
3	Valve disc	14	O-ring
4	Fastening ring	15	Grooved pin
5	Bonnet flange	16	Stud bolt
6	Bonnet	17	Stud bolt
7	Bushing	18	Nut
8	Sealing ring	19	O-ring
9	Washer	20	Lower disc
10	V-ring packing	21	Screw
11	Belleville spring washer		

Table 1 - parts list

Principle of operation:

The process medium can flow through the butterfly valve in either direction. The butterfly disc (3) determines the flow through the free area between disc and seat. The shaft (2) is sealed by a V-ring packing (10).

Butterfly valves are sealed between the butterfly disc (3) and the seat. The direction of flow and the differential pressure determine the breakaway torque to open the butterfly valve.

The double eccentric bearing design of the shaft causes the disc on opening and closing to remain in contact with the seat only over a very small angle of rotation (Fig. 4). This reduces wear and increases the service life of the valve. In addition, it reduces the breakaway torque.

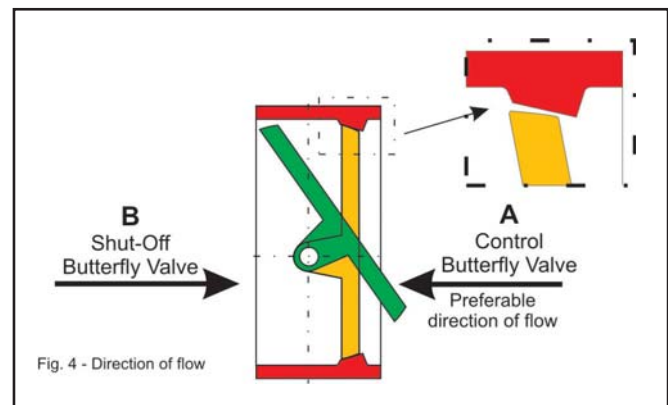

When the process medium flows through the valve in direction A (Fig. 4), the butterfly disc is slightly lifted out of the seat from a certain differential pressure onwards. This reduces the breakaway torque.

When the process medium flows through the valve in direction B, the butterfly disc is pressed firmly into the seat as the differential pressure rises. This results in a better tightness is achieved, however, the breakaway torque increases as well.



Failure position: In dependence of mounting position of the actuator there are two failure positions, which take place by pressure relieving or on failure of air supply:

- **Butterfly valve with actuator “ on failure closing “**
on failure of air supply the butterfly valve closes. The opening of the butterfly valve occurs on rising of air supply against the force of the springs.
- **Butterfly valve with actuator “ on failure opening “**
on failure of air supply the butterfly valve opens. The closing of the butterfly valve occurs on rising of air supply against the force of the springs.



Note:

Before using the butterfly valve in hazardous areas, check whether this is possible according to ATEX 94/9/EC.

See Operating Instructions <BA 14b>.

General technical data:

Nominal size	DN 80 to DN 500 and 3" to 20"
Nominal pressure	PN 10 as well as ANSI 150 lbs
End connection	can be mounted between PN 10 or ANSI 150 lbs
Temperature range	see Pressure-Temperature diagram
Rangeability	50 : 1
Leakage for direction of flow	A On request as it depends on pressure and temperature
	B Leckrate A nach DIN EN 12266-1, Prüfung P12 (Leckrate 1 BO nach DIN 3230 Teil 3)

Table 2 - technical data

Materials:

Valve body	special material
Valve disc	
Valve shaft	
Fastening ring	
Packing box flange	
Sealing ring	PTFE with 20% glass
Stuffing box packing	Live-loadet PTFE V-ring packing

Table 3 - materials

Terms for noise level calculation:

Z-values for noise level calculation according to VDMA 24422 and Terms for control valve sizing acc. to DIN EN 60534.

φ	10°	20°	30°	40°	50°	60°	70°	80°	90°
FL	0.95	0.95	0.92	0.82	0.74	0.67	0.61	0.57	0.54
χ_T	0.75	0.75	0.73	0.57	0.47	0.38	0.31	0.28	0.25
Z	0.35	0.30	0.25	0.20	0.17	0.15	0.13	0.12	0.11

Table 4 - noise level calculation and terms for control valve sizing

Correction terms:

with liquids

$$\Delta LF = 0,$$

with gases and vapors

$$\Delta LG = 0$$

Pressure-Temperature diagram:

The area of application is determined by the pressure-temperature diagram. Process data and the process medium can affect the values in the diagram.

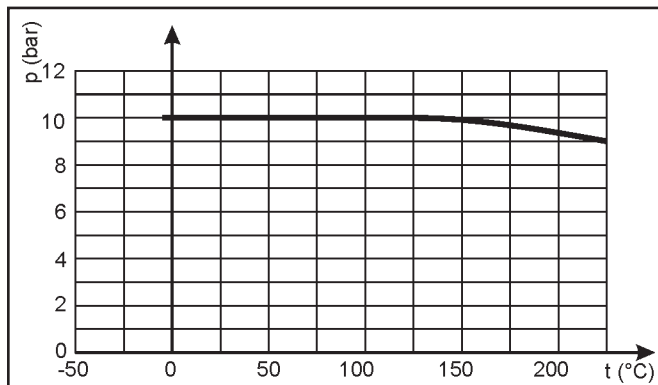

Fig. 5 - pressure-temperature diagram

Torque and breakaway torques:

Differential pressure Δp in bar		0	1	2	3	5
DN	max. perm. Torque M_{dmax} in Nm	Breakaway torque M_{di} in Nm				
80 / 3"	80	29	31	34	36	41
100 / 4"	157	46	50	55	60	69
150 / 6"	272	104	119	135	150	182
200 / 8"	432	185	222	259	296	370
250 / 10"	650	289	361	433	506	650
300 / 12"	844	416	541	666	791	
400 / 16"	1795	740	1036	1332	1638	
500 / 20"	1982	1156	1735			

Table 5 - max. permissible torque M_{dmax} , required torque M_d and breakaway torque M_{di}

The breakaway torques specified are average values which were measured with air at 20°C with the corresponding differential pressures. Operating temperature, process medium and long operating times may affect the permissible torques and breakaway torques considerably.

Characteristic curve and functional diagram with opening angles:

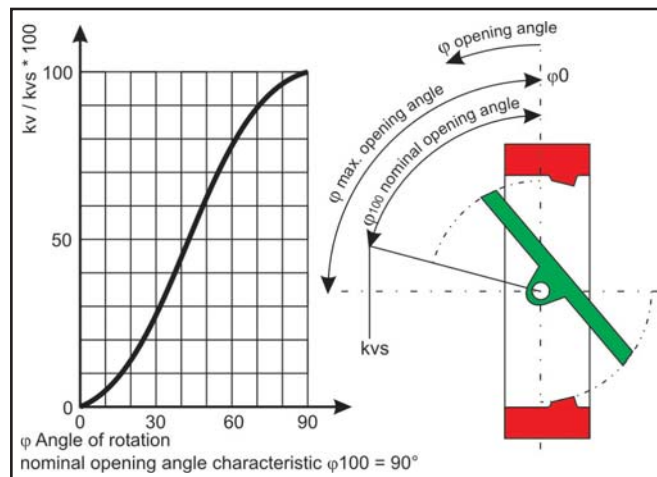

Fig. 6 - characteristic curve and functional diagram with opening angles

kv values and associated opening angles:

DN	Opening angle φ								
	10°	20°	30°	40°	50°	60°	70°	80°	90°
80 / 3"	4,5	23	45	68	93	118	133	147	150
100 / 4"	7	36	72	108	149	190	214	235	240
150 / 6"	21	105	210	315	434	553	623	686	700
200 / 8"	42	208	417	625	862	1098	1237	1362	1390
250 / 10"	68	341	681	1022	1407	1793	2020	2224	2270
300 / 12"	100	501	1002	1503	2071	2639	2973	3273	3340
400 / 16"	183	915	1830	2745	3782	4819	5429	5978	6100
500 / 20"	289	1443	2886	4329	5964	7600	8562	9427	9620

Table 6 - kv values

Dimensions and weights:

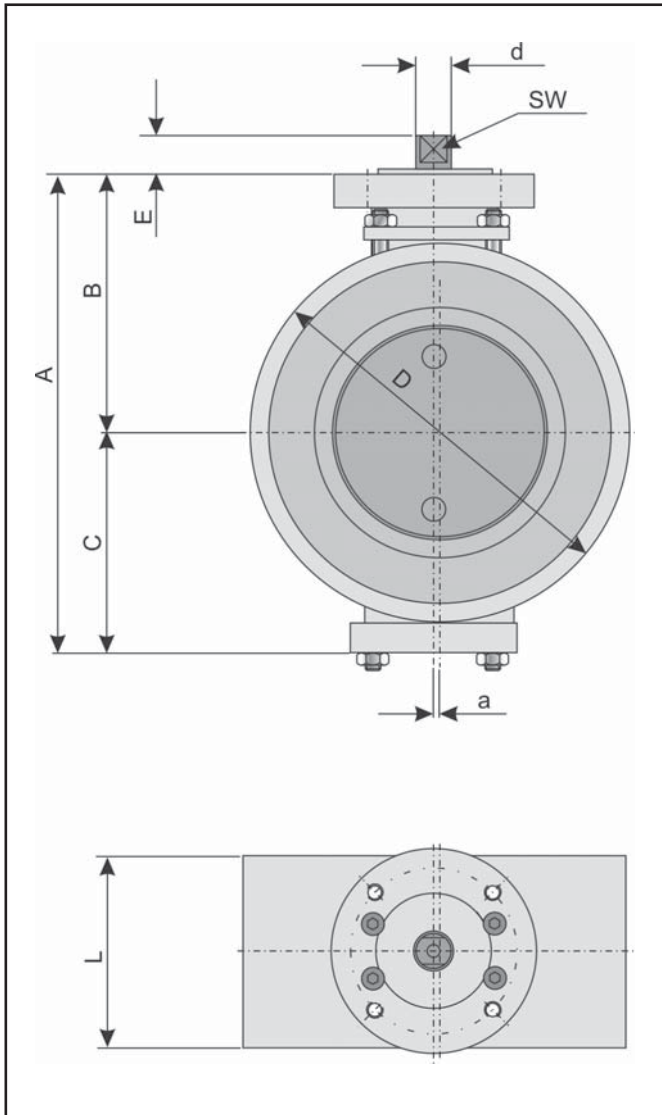

Fig. 7 – dimensional diagram

DN	80 3"	100 4"	150 6"	200 8"	250 10"	300 12"	350 14"	400 16"	500 20"
A	184	214	282	342	445	503	624	680	819
B	104	124	165	194	267	298	339	369	445
C	80	90	117	148	178	205	285	311	374
ØD	140	160	215	272	326	378	438	489	594
E	19	19	23	27	27	31	31	41	44
L	64	64	76	89	114	114	127	140	152
a	1,6	2	3	4	5	6	7	8	10
SW	12	12	16	20	20	24	24	32	34
Ø d	16	20	24	28	32	35	40	45	55
DIN ISO Connection	F05	F05	F07	F07	F10	F12	F14	F14	F16
Weight	11	14	22	33	45	57	75	89	123

Table 7 - dimensions in mm and wights in kg

Selecting and sizing the butterfly valve:

1. Calculate the appropriate kv value.
2. Select the nominal size and the kvs value from Table 6.
3. Comparing the operation conditions in accordance to the pressure-temperature diagram.
4. Select a suitable actuator.
5. If required, also special materials / higher temperatures.

Ordering text:

Control / shut-off butterfly valve Series 14a,
 DN / PN , optional special version
 Manual gear actuator or actuator (brand name):
 Supply pressure: bar, fail-safe position:
 Limit switch (brand name):
 Solenoid valve (brand name):
 Positioner:
 Others:



Note: All relevant details regarding the version ordered, which deviate from the specified version in this technical description data, can be taken if required, from the corresponding order confirm.

For your special requirements please contact our technical sales department.

Pfeiffer Chemie-Armaturenbau GmbH

Hooghe Weg 41 • 47906 Kempen

Telefon: 02152 / 2005-0 • Telefax: 02152 / 1580

E-Mail: vertrieb@pfeiffer-armaturen.com • Internet: www.pfeiffer-armaturen.com

Values subject to change