

Control Butterfly Valve (Centric Version) Series 14e

Application:

Butterfly valve for plant and process engineering, especially suitable for fluids, vapors and gaseous medium, for high requirements in chemical plants:

- Nominal sizes DN 50 to DN 300
- Nominal pressure PN 10, PN 16 possible
- Temperatures -10°C up to 200°C

The control element consists of a sweeping disc and can be provided with a pneum. actuator or with a manual gearbox.

The control valves designed in the modular principle can be combined with various accessories and are equipped with the following special features:

- Valve body of stainless steel.
- Can be mounted between flanges acc. DIN.
- Exchangeable actuator.
- Valve shaft sealing through live-loadet PTFE V-ring packing.
- Attachment options according to DIN ISO 5211.
- Face-to-face acc. to DIN EN 558-1, basic series 20, (K1 acc. to DIN 3202).

Versions:

Butterfly control valve Series 14e optionally available in the following versions:

- Hand lever / grid plate.
- Manual gear actuator.
- Pneumatic rotary actuator Series 31a.
- Pneumatic diaphragm rotary actuator Series 30a.

Special versions:

- Nominal size > DN 300 on request.
- Precious materials, e.g. 1.4412, 1.4539, 1.4462.
- Electric rotary actuator.
- Highly wear resistant coating of valve body, shaft and disc.
- Groove in raised face acc. to DIN EN 1092.
- High temperature version.
- Optional materials.

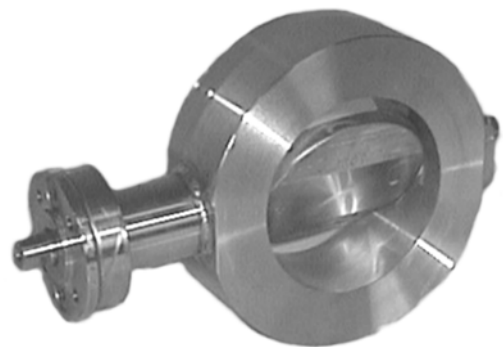

Fig. 1 - Butterfly valve Series 14e

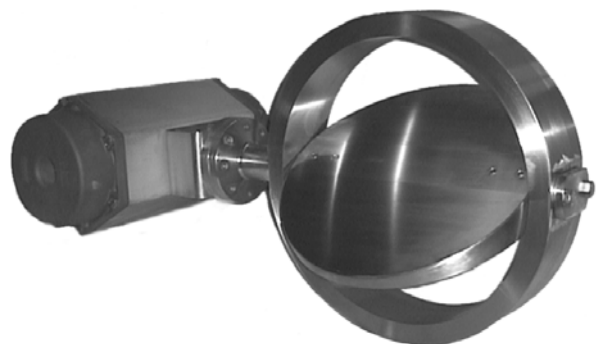

Fig. 2 - Butterfly valve Series 14e with pneumatic rotary actuator Series 31a

Butterfly valve Series 14e

Additional accessories:

The control valves are also available without any accessories or in combination with the following parts:

- Positioner
- Limit switch
- Solenoid valve
- Air sets
- Gauge block

Other special accessories are available on request.

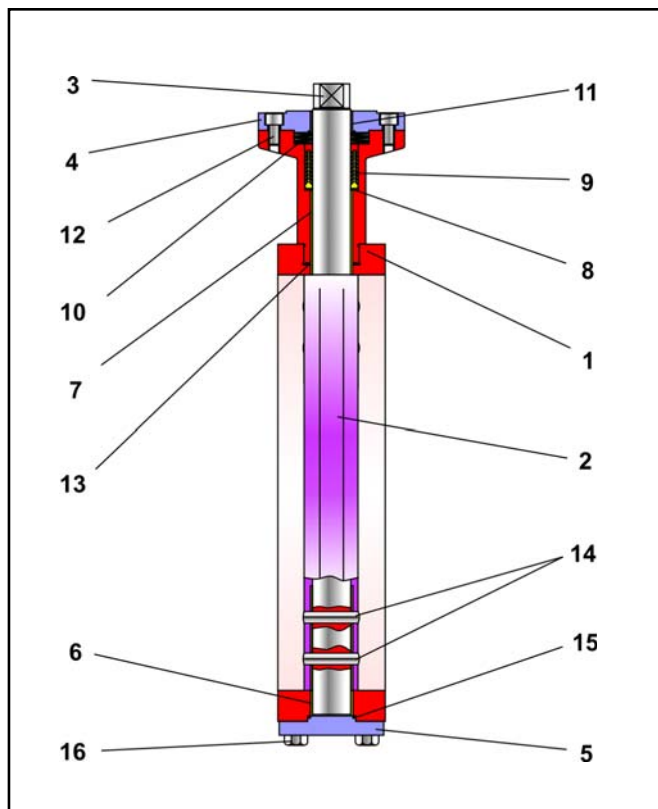

Fig. 3 - Butterfly valve Series 14e

Pos.	Description	Pos.	Description
1	Valve body	9	V-ring packing
2	Valve disc	10	Belleville spring washer
3	Valve shaft	11	Bearing bushing
4	Stuffin box flange	12	Screw
5	Bonnet	13	O-ring
6	Bearing bushing	14	Grooved pin
7	Bearing bushing	15	O-ring
8	Washer	16	Screw

Table 1 - Parts list

Principle of operation:

The process medium can flow through the butterfly valve in either direction.

The position of the butterfly disc (2) determines the flow rate through the free area between the disc and seat (1).



Failure position: In dependance of mounting position of the actuator there are two failure positions, wich take place by pressure relieving or on failure of air supply:

- **Butterfly valve with actuator “ on failure closing “**
on failure of air supply the butterfly valve closes.
The opening of the butterfly valve accures on rising of air supply against the force of the springs.
- **Butterfly valve with actuator “ on failure opening “**
on failure of air supply the butterfly valve opens.
The closing of the butterfly valve accures on rising of air supply against the force of the springs.



Note:

Before using the butterfly valve in hazardous areas, check whether this is possible according to ATEX 94/9/EC.
See **Operating Instructions <BA 14b>**.

General technical data:

Nominal size	DN 50 to DN 300
Nominal pressure	PN 10
End connection	can be mounted between PN 10
Temperature range	see Pressure-Temperature-diagram
Rangeability	50 : 1
Sealing effectiveness	$< 10^{-6}$ mbar l / sec

Table 2 - technical data

Materials:

Valve body	1.4571 / 1.4581
Valve disc	1.4571
Valve shaft	1.4571
Bushing	PTFE
Bearing bushing	PTFE with 25% Carbon
Stuffing box packing	Live-loadet PTFE V-ring packing

Table 3 - Materials

Terms for noise level calculation:

z-values for noise level calculation acc. to VDMA 24422

φ	10°	20°	30°	40°	50°	60°	70°	80°	90°
Z	0.35	0.30	0.25	0.20	0.17	0.14	0.12	0.11	0.10

Table 4 - noise-dependet control valve „z“ according to VDMA 24422

Correction terms:

with liquids

$$\Delta LF = 0,$$

with gases and vapors

$$\Delta LG = 0$$

Terms for control valve sizing:

for control valve sizing acc. to DIN EN 60534 opening angle.

φ	10°	20°	30°	40°	50°	60°	70°	80°	90°
FL	0.95	0.95	0.92	0.83	0.73	0.65	0.58	0.53	0.50
xT	0.75	0.75	0.73	0.58	0.46	0.36	0.29	0.24	0.21

Table 5 – terms for control valve sizing

Pressure-Temperature diagram:

The area of application is determined by the pressure-temperature diagram. Process data and the process medium can affect the values in the diagram.

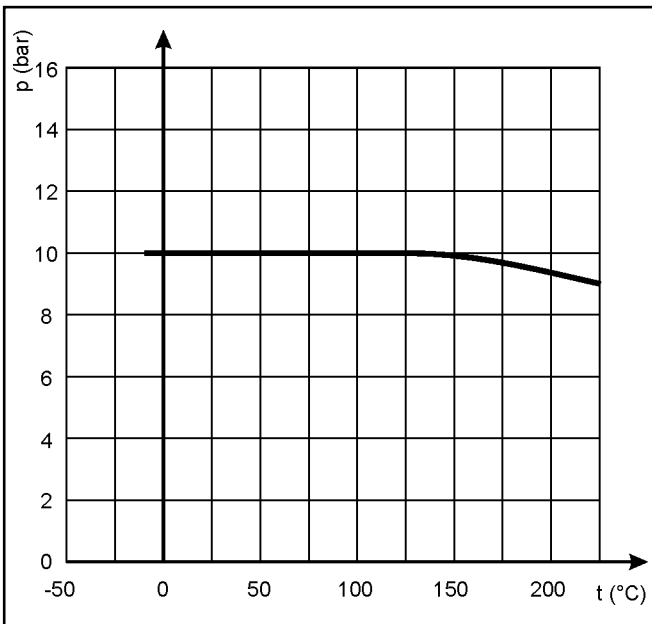

Fig. 4 - pressure-temperature diagram

Torque and breakaway torques:

DN	50	80	100	150	200	250	300
max. zul. Drehmoment in Nm	1.4462	204	204	204	420	420	846
	1.4539	99	99	99	205	205	414
	1.4571	95	95	95	196	196	395
erforderliches Drehmoment in Nm	19	29	46	58	98	125	196

Table 6 - max. permissible torque, required torque and breakaway torque

The breakaway torques specified are average values which were measured with air at 20°C with the corresponding differential pressures. Operating temperature, process medium and long operating times may affect the permissible torques and breakaway torques considerably.

Functional diagram with opening angles:

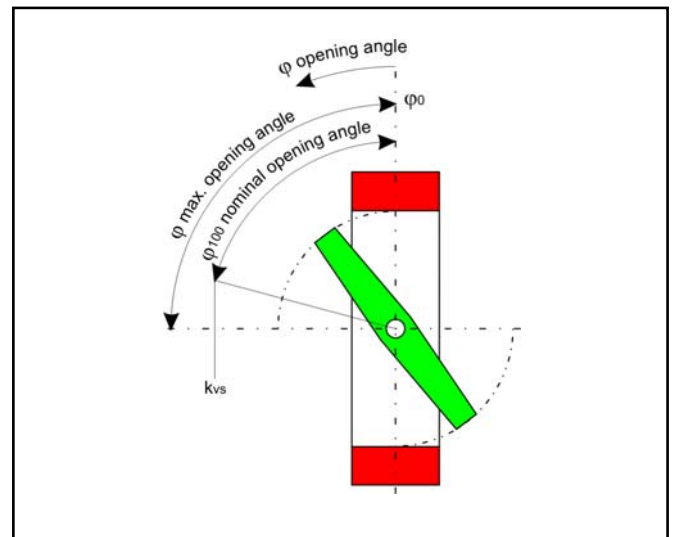

Fig. 5 – functional diagram with opening angles

kv values and associated opening angles:

DN	Opening angle φ								
	10°	20°	30°	40°	50°	60°	70°	80°	90°
50	1.8	7	16	26	44	70	115	175	210
80	3.5	14	33	57	95	146	240	380	510
100	5.5	25	54	95	155	240	395	620	820
150	14.5	52	120	215	342	547	940	1380	1800
200	20.5	95	215	376	590	940	1540	2400	3200
250	33	154	342	607	940	1540	2310	4000	5300
300	49	222	504	855	1455	2310	3760	6000	8000

Table 7 – kv values

Dimensions and weights:

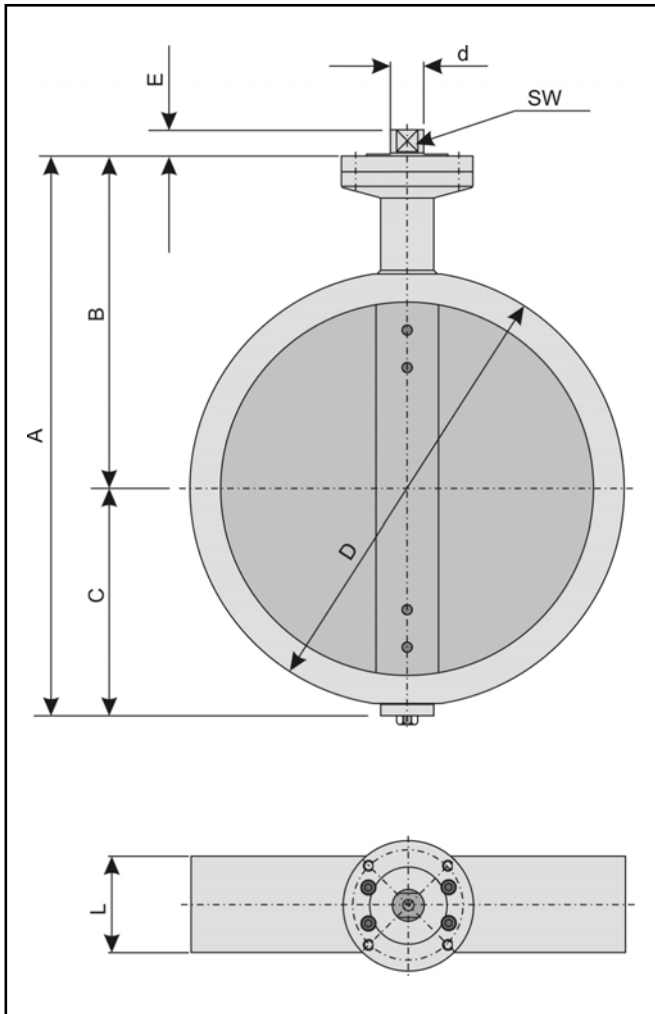

Fig. 6 – dimensional diagram

DN	50	80	100	150	200	250	300
A	170	202	231	297	357	421	488
B	117	127	145	185	214	252	286
C	53	75	86	112	143	169	202
ØD	105	140	160	215	273	328	378
E	19	19	19	23	23	27	32
L	43	46	52	56	60	68	78
SW	12	12	12	16	16	20	25
Ø d	16	16	16	20	20	24	34
DIN ISO Connection	F 05	F 05	F 05	F 07	F 07	F 10	F 10
Weight in kg	3,5	5	8	15	22	45	-

Table 8 - dimensions in mm and wights in kg

Selecting and sizing the butterfly valve:

1. Calculate the appropriate kv value.
2. Select the nominal size and the kvs value from Table 7.
3. Comparing the operation conditions in accordance to the pressure-temperature diagram.
4. Select a suitable actuator.

Ordering text:

Control butterfly valve Series 14e,
 DN / PN , optional special version
 Manual gear actuator or actuator (brand name):
 Supply pressure: bar, fail-safe position:
 Limit switch (brand name):
 Solenoid valve (brand name):
 Positioner:
 Others:



Note: All relevant details regarding the version ordered, which deviate from the specified version in this technical description data, can be taken if required, from the corresponding order confirm.

For your special requirements please contact our technical sales department.

Pfeiffer Chemie-Armaturenbau GmbH

Hooghe Weg 41 • 47906 Kempen • Germany
 Phone: +49 2152 2005 - 0 • Fax: +49 2152 1580

E-Mail: vertrieb@pfeiffer-armaturen.com • Internet: www.pfeiffer-armaturen.com

Values subject to change