

# Rotary Plug Valve Series 23a in stainless steel

## Application:

Stainless steel rotary plug valve with high flow capacity for technical process plants, especially at media with solid parts:

- Diameter from DN 25 up to DN 150.
- Nominal pressure from PN 10 to PN 40.
- Temperature -10°C up to 200°C.

The control equipment consists of a rotary plug valve and a pneumatic quarter-turn actuator or a hand-operated actuator.

The valve is designed according to the modular-assembly principle and has the following features:

- Pocket free design with high flow capacity at low leakage, applicable at media with solid particulates, polluted flow and high viscosity.
- Anticorrosive Stainless steel one-piece valve body.
- Stem sealed by spring-loaded PTFE V-ring packing.
- Electrical conductive plug confirmed.
- Face-to-face dimension acc. to DIN EN 558-1, Series 1 (DIN 3202, Series F1)
- Mounting acc. to DIN ISO 5211.

## Versions:

The Series 23a Rotary Plug Valve is available in the following versions:

- Rotary plug valve with hand-operated actuator.
- Rotary plug valve with pneumatic quarter-turn actuator, (for details see respective data sheet).

## Special design:

- Heating jackets
- Body and ball segment are available in noble metals (e.g. Hastelloy and nickel)
- Latent range regarding diameter and temperature, from -200°C up to 450°C
- Double stuffing box with leakage detecting connection.

**Note:**  
**This series of rotary plug valves  
are no longer in the current  
product range !**

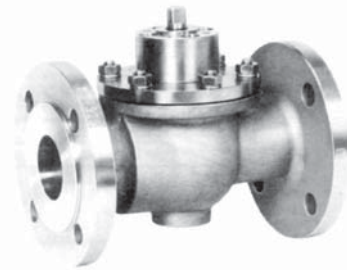

•Fig. 1 - Rotary Plug Valve Series 23a



Fig. 2 - Rotary Plug Valve Series 23a with hand gear box

# Rotary Plug Valve Series 23a

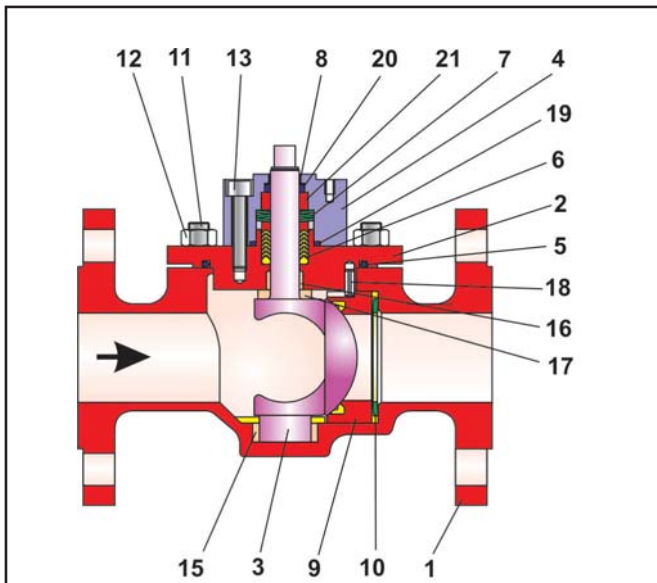

Fig. 3 - Sectional diagram of Series 23b Rotary Plug Valve

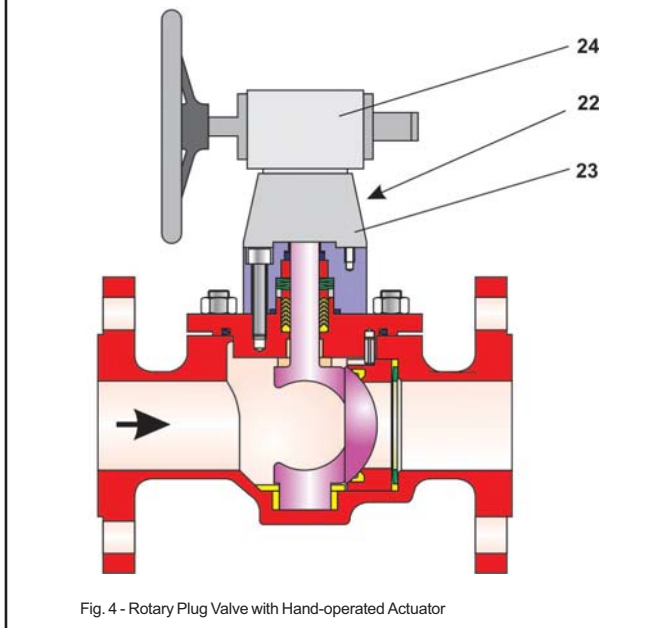

Fig. 4 - Rotary Plug Valve with Hand-operated Actuator

Item	Description	Item	Description
1	Valve body	13	Screw
2	Bonnet flange	15	Bearing bushing
3	Rotary plug with stem	16	Bearing bushing
4	Stuffing box flange	17	Distance washer
5	Bonnet seal	18	Grooved pin
6	V-ring packing	19	O-ring
7	Set of spring washers	20	O-ring
8	Bearing bushing	21	Distance bushing
9	Seat ring	22	Adapter
10	Spring washer	23	Yoke
11	Stud bolt	24	Hand gear box
12	Nut		

Table 1 - List of parts

## Principle of operation:

The media flow is basically in arrow direction. At special application contrary flow direction is possible. Further details on request.

The ball segment ( 3 ) determines the flow through the free area between the ball and seating.

The seating ( 9 ) confirms the tightness of the valve. This construction confirms a higher tightness, higher flow capacity and a more easier interchangeability of the seatings.

The stem is sealed by a maintenance free PTFE - V-ring packing ( 6 ). The spring washers ( 7 ) affect a prestressing of this.



**Note:** Please, pay attention to the usability acc. to the ATEX 94/9/EG in correspondance to the maintenance sheet before using the ball valve in hazardous area!



**Failure position:** In dependance of mounting position of the actuator there are two failure positions, wich take place by pressure relieving or on failure of air supply:

- **Ball valve with actuator “ on failure closing “**  
on failure of air supply the ball valve closes. The opening of the ball valve accures on rising of air supply against the force of the springs.
- **Ball valve with actuator “ on failure opening “**  
on failure of air supply the ball valve opens. The closing of the ball valve accures on rising of air supply against the force of the springs.

## General technical data:

Nominal Diameter	DN 25 up to DN 150
Nominal Pressure	PN 10, PN 16, PN 25 or PN 40
Temperature range	-10°C up to 200°C
Rotary plug seal	soft - sealing
Leakage rate	Leakage rate A acc. to DIN EN 12266-1, P12 (Leakage rate 1 BO acc. to DIN 3230 Part 3)
Basic characteristic	see diagram
Rangeability	50 : 1
Flanges	all DIN versions

Table 2 - Technical data

## Materials:

Body and Rotary plug	1.4581
Seat ring	1.4571
Sealing ring	TFM (PTFE)
Spring washer	1.4401 encapsulated in pure PTFE
Packing	PTFE - V-ring-packing with spring washers in 1.8159, Delta Tone
Bearing	PTFE with 40% glas
Bonnet seal	EPDM O-ring encapsulated in pure PTFE

Table 3 - Materials

### Terms for noise level calculation:

z-values for noise level calculation acc. to VDMA 24422

DN	25	60	80	100	150
z	0.15	0.15	0.1	0.1	0.1

Table 4 - noise-dependent control valve „z“ according to VDMA 24422

### Correction terms:

with liquids

$$\Delta LF = 0,$$

with gase and vapor

$$\Delta LG = 0$$

### Terms for control valve sizing:

for control valve sizing acc. to DIN EN 60534 opening angle.

$\phi$	30°	40°	50°	60°	70°	80°	90°
FL	0.75	0.73	0.72	0.70	0.59	0.55	0.55
$\chi_T$	0.47	0.45	0.44	0.41	0.30	0.26	0.25

Table 5 – Terms for control valve sizing

### Torque and breakaway torques:

DN	perm. torque Mdmax. in Nm	Required torque Md in Nm	req. breakaway torque Mdl in Nm
25	134	10	10
50	134	25	25
80	419	60	60
100	577	90	90
150	1455	250	250

Table 6 - max. permissible torque Mdmax., required torque Md and breakaway torque Mdl

The breakaway torques specified are average values which were measured with air at 20°C with the corresponding differential pressures. Operating temperature, process medium and long operating times may affect the permissible torques and breakaway torques considerably. The listed max. permissible operating torques are valid for the standard materials in table 3.

### Pressure-Temperature diagram:

The area of application is determined by the pressure-temperature diagram. Process data and the process medium can affect the values in the diagram.

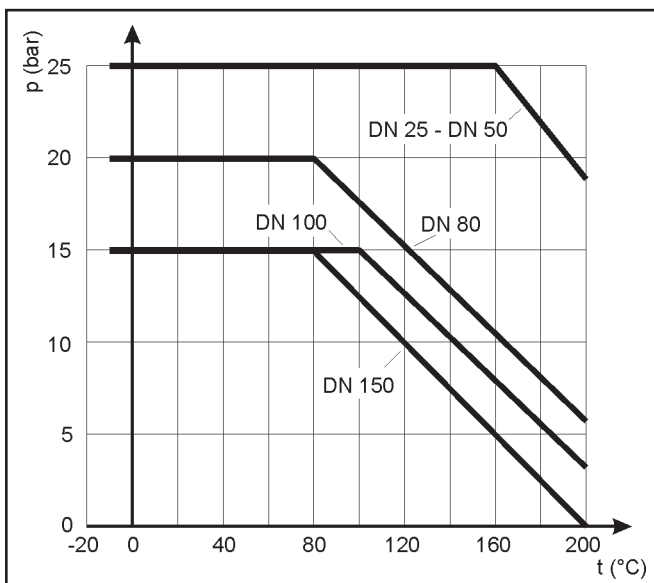

Fig. 5 - Pressure-Temperature Diagram

### Functional diagram with opening angles:

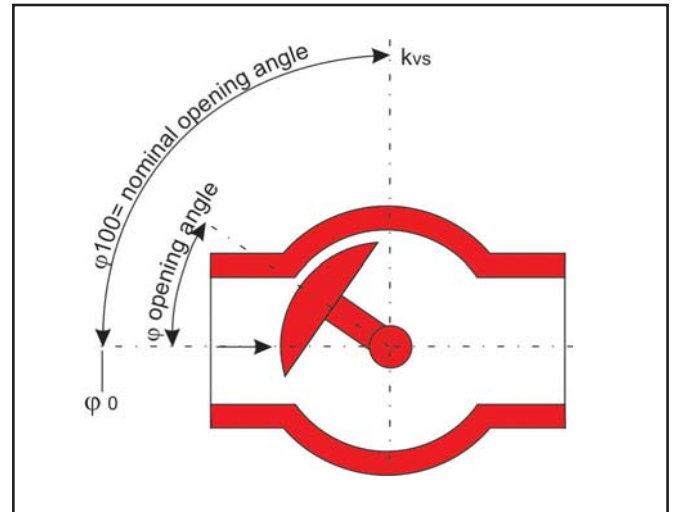

Fig. 6 - Functional diagram with opening angles

### kv - values and associated angles:

DN	opening angle $\phi$									
	10°	20°	30°	40°	50°	60°	70°	80°	90°	
25	kv	0.06	1.4	3	6	10.4	15.5	22.5	27.5	30
	Cv	0.07	1.6	3.5	7	12	18	26	32	35
50	kv	0.25	3.6	13	24	45	68	98	123	130
	Cv	0.29	4.8	15	28	53	80	115	144	152
80	kv	0.65	15	32	64	110	165	240	295	320
	Cv	0.76	18	37	75	129	193	281	345	374
100	kv	1.0	23	50	100	173	260	375	460	500
	Cv	1.2	27	59	117	202	304	439	538	585
150	kv	2.4	56	120	240	416	624	900	1105	1200
	Cv	2.8	66	140	281	487	730	1053	1293	1404

Table 7 - kv-value

### Characteristic curve:

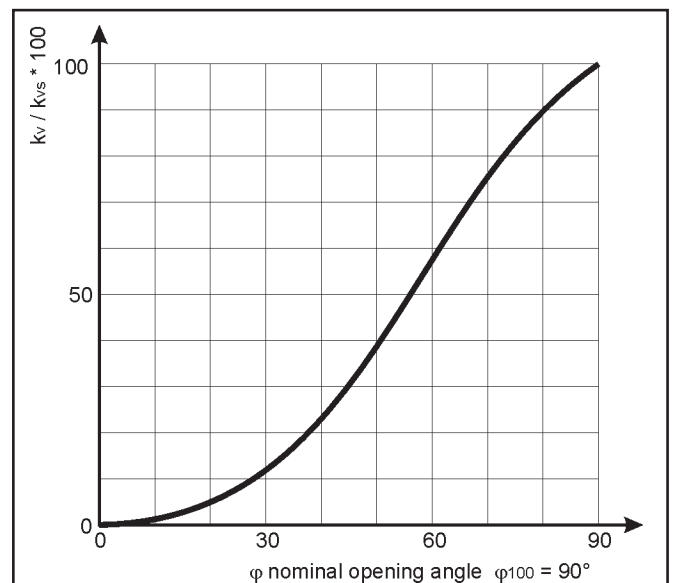

Fig. 7 - Characteristic curve

## Dimensions and weights:

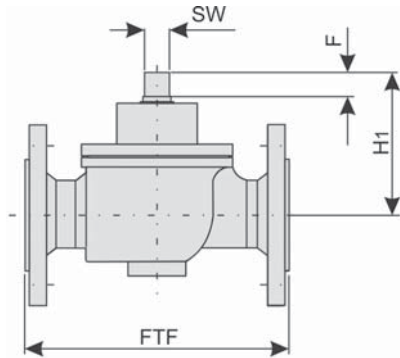

Fig. 8 - Rotary plug valve

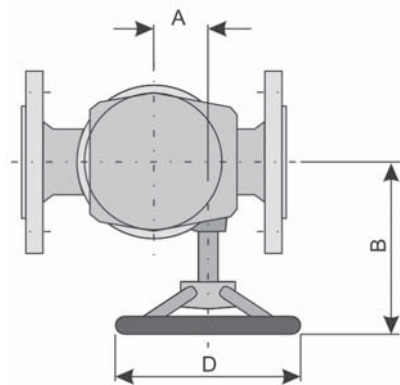
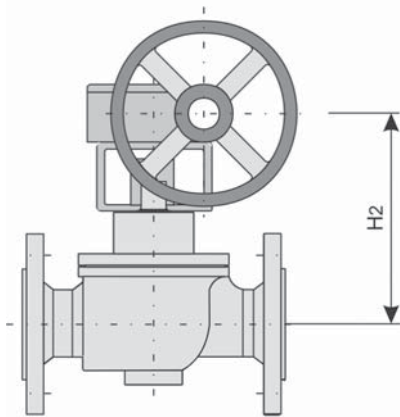

Fig. 9 - Rotary plug valve with hand gear box

DN	25	50	80	100	150
FTF	160	230	310	350	480
F	12	12	12	12	18
DIN/ISO Connection	F05	F05	F07	F07	F10
H <sub>1</sub>	100	118	131	155	230
SW	12	12	16	16	24
Weight of the valve	5	13	26	35	120
H <sub>2</sub>	170	200	220	230	315
A	45	45	45	45	45
B	150	150	150	150	150
D	200	200	200	200	200
complete weight with gear box	8	16	29	38	125

Table 8 - Dimensions in mm and weights in kg

### Selecting and sizing the rotary plug valve:

1. Calculate the appropriate kv value.
2. Select the nominal size and the kvs value from Table 7.
3. Comparing the operation conditions in accordance to the pressure-temperature diagram.
4. Select a suitable actuator.

### Ordering text:

Rotary Plug Valve Series 23a,  
 DN . . . . / PN . . . . , optional special version  
 Manual gear actuator or actuator (brand name): . . . .  
 Supply pressure: . . . . bar, fail-safe position: . . . .  
 Limit switch (brand name): . . . .  
 Solenoid valve (brand name): . . . .  
 Positioner: . . . .  
 Others: . . . .



**Note:** All relevant details regarding the version ordered, which deviate from the specified version in this technical description data, can be taken if required, from the corresponding order confirm.

For your special requirements please contact our technical sales department.

## Pfeiffer Chemie-Armaturenbau GmbH

Hooghe Weg 41 • 47906 Kempen • Germany

Telefon: +49 21 52 20 05 - 0 • Telefax: +49 21 52 15 80

E-Mail: [vertrieb@pfeiffer-armaturen.com](mailto:vertrieb@pfeiffer-armaturen.com) • Internet: [www.pfeiffer-armaturen.com](http://www.pfeiffer-armaturen.com)

Values subject to change