

Rotary Plug Valve Series 23b in stainless steel

Application:

Stainless steel rotary plug valve with high flow capacity for technical process plants, especially at media with solid parts:

- nominal diameters DN 25 to DN 150.
- nominal pressure PN 10 to PN 40.
- Temperature -10°C to 200°C.

The control equipment consists of a stainless steel rotary plug valve and a pneumatic quarter-turn actuator or a hand-operated actuator.

The valve is designed according to the modular-assembly principle and has the following features:

- Pocket free design with high flow capacity at low leakage, applicable at media with solid particulates, polluted flow and high viscosity.
- Anticorrosive Stainless steel one-piece valve body.
- Stem sealed by spring-loaded PTFE V-ring packing.
- Electrical conductive plug confirmed.
- Face-to-face dimension acc. to DIN EN 558-1, Series 1 (DIN 3202, Series F1)
- Mounting acc. to DIN ISO 5211.

Versions:

The Series 23b Rotary Plug Valve is available in the following versions:

- Rotary plug valve with hand-operated actuator.
- Rotary plug valve with pneumatic quarter-turn actuator, (for details see respective data sheet).

Special design:

- Heating jackets.
- Body and ball segment are available in special materials (e.g. Hastelloy or nickel).
- Latent range regarding diameter and temperature, from -200°C up to 450°C.
- Solenoid coupling.
- Double stuffing box with leakage detecting connection.
- High pressure up to PN 160.
- Full bore.
- ANSI - Design.



Fig. 1 - Series 23b Rotary Plug Valve

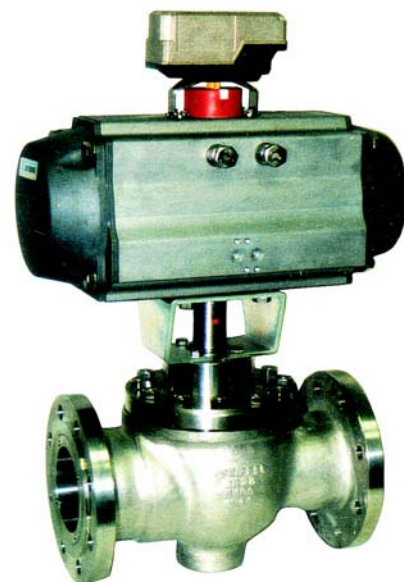

Fig. 2 - Series 23b Rotary Plug Valve with Series 31a Quarter-Turn Actuator

Rotary Plug Valve Series 23b

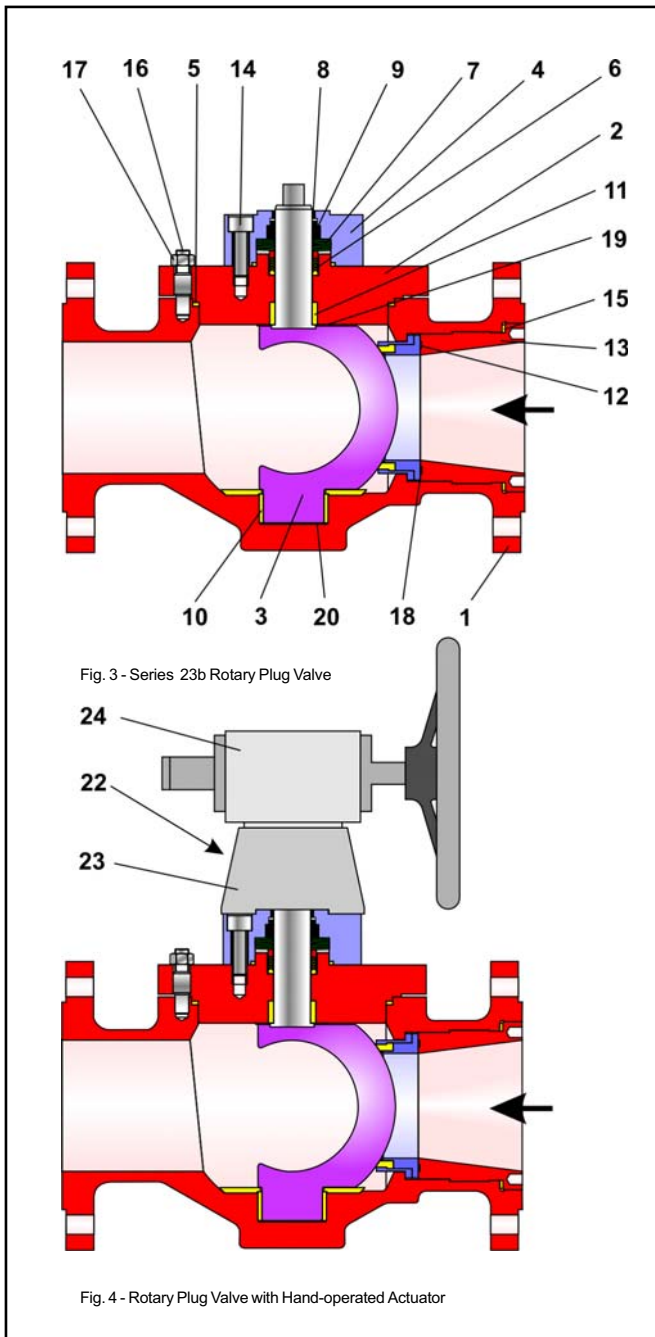

Fig. 3 - Series 23b Rotary Plug Valve

Fig. 4 - Rotary Plug Valve with Hand-operated Actuator

Principle of operation:

The media flow is basically in arrow direction.

The ball segment (3) determines the flow through the free area between the ball and seating.

The seating (12) confirms the tightness of the valve. This construction confirms a higher flow capacity and a more easier interchangeability of the seatings.

The stem is sealed by a maintenance free PTFE - V-ring packing (6). The spring washers (7) affect a prestressing of this.



Note: Please, pay attention to the usability acc. to the ATEX 94/9/EG in correspondence to the maintenance sheet before using the ball valve in hazardous area!



Failure position: In dependance of mounting position of the actuator there are two failure positions, wich take place by pressure relieving or on failure of air supply:

- **Ball valve with actuator “ on failure closing “**
on failure of air supply the ball valve closes. The opening of the ball valve accures on rising of air supply against the force of the springs.
- **Ball valve with actuator “ on failure opening “**
on failure of air supply the ball valve opens. The closing of the ball valve accures on rising of air supply against the force of the springs.

General technical data:

Nominal size	DN 25 to DN 150
Nominal pressure	PN 10, PN 16, PN 25 or PN 40
Temperature range	-10°C to 200°C
Control valve leakage rate	0,001% of the kvs value at $\varphi=90^\circ$
Shut-off valve leakage rate	Leakage rate A acc. to DIN EN 12266-1, P12 (Leakage rate 1 BO acc. to DIN 3230 Part 3)
Rangeability	50 : 1
Enf connections	all DIN versions

Table 2 - Technical data

Materials:

Body	1.4408 / 1.4571
Rotary plug with stem	1.4408 / 1.4571
Seat ring	1.4571
Sealing ring	TFM (PTFE)
Packing	PTFE - V-ring packing loaded by Belleville washers (1.8159)
Bearing bushing	TFM
Bonnet seal	PTFE O-ring

Table 3 - Materials

Pos.	Description	Pos.	Descripton
1	Valve body	13	Spacer
2	Bonnet flange	14	Screw
3	Rotary plug with stem	15	Body sealing
4	Stuffing box flange	16	Stud bolt
5	Bonnet seal	17	Nut
6	V-ring packing	18	Seal
7	Set of disc springs	19	Distance washer
8	Bearing bushing	20	Washer
9	Distance washer	22	Adaptor
10	Bearing bushing	23	Yoke
11	Bearing bushing	24	Hand gear box
12	Seat ring		

Table 1 - List of parts

Terms for noise level calculation:

z-values for noise level calculation acc. to VDMA 24422

DN	25	60	80	100	150
z	0.15	0.15	0.1	0.1	0.1

Table 4 - noise-dependent control valve „z“ according to VDMA 24422

Correction terms:

with liquids $\Delta LF = 0$,
with gase and vapor $\Delta LG = 0$

Terms for control valve sizing:

for control valve sizing acc. to DIN EN 60534 opening angle.

ϕ	30°	40°	50°	60°	70°	80°	90°
FL	0.75	0.73	0.72	0.70	0.59	0.55	0.55
xT	0.47	0.45	0.44	0.41	0.30	0.26	0.25

Table 5 – Terms for control valve sizing

Torque and breakaway torques:

DN	perm. torque M _{dmax.} in Nm	required torque M _d in Nm	req. breakaway torque M _{d1} in Nm
25	168	10	10
50	226	25	25
80	437	60	60
100	749	90	90
150	1497	250	250

Table 6 - max. permissible torque M_{dmax.}, required torque M_d and breakaway torque M_{d1}

The breakaway torques specified are average values which were measured with air at 20°C with the corresponding differential pressures. Operating temperature, process medium and long operating times may affect the permissible torques and breakaway torques considerably. The listed max. permissible operating torques are valid for the standard materials in table 3.

Pressure-Temperature diagram:

The area of application is determined by the pressure-temperature diagram. Process data and the process medium can affect the values in the diagram.

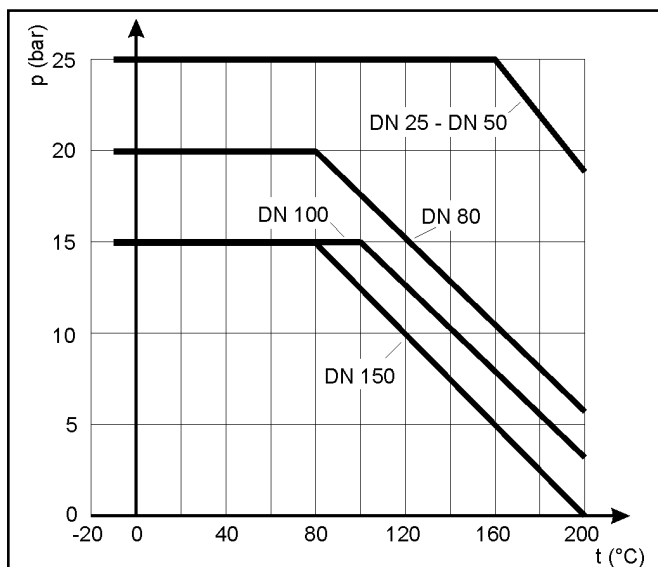

Fig. 5 - Pressure-Temperature Diagram

Functional diagram with opening angles:

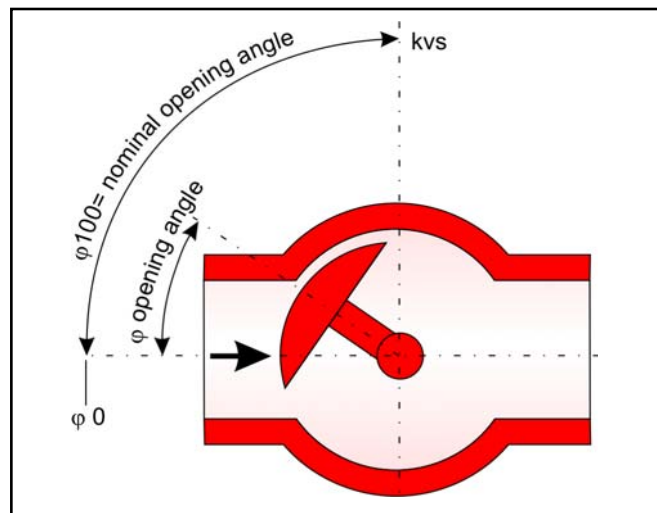

Fig. 6 - Functional diagram with opening angles

kv - values and associated angles:

DN	kv/ Cv	ϕ opening angle								
		10°	20°	30°	40°	50°	60°	70°	80°	90°
25	kv	0.06	1.4	3	6	10.4	15.5	22.5	27.5	30
	Cv	0.07	1.6	3.5	7	12	18	26	32	35
50	kv	0.25	3.6	13	24	45	68	98	123	130
	Cv	0.29	4.8	15	28	53	80	115	144	152
80	kv	0.65	15	32	64	110	165	240	295	320
	Cv	0.76	18	37	75	129	193	281	345	374
100	kv	1.0	23	50	100	173	260	375	460	500
	Cv	1.2	27	59	117	202	304	439	538	585
150	kv	2.4	56	120	240	416	624	900	1105	1200
	Cv	2.8	66	140	281	487	730	1053	1293	1404

Table 7 - kv-value

Characteristic curve:

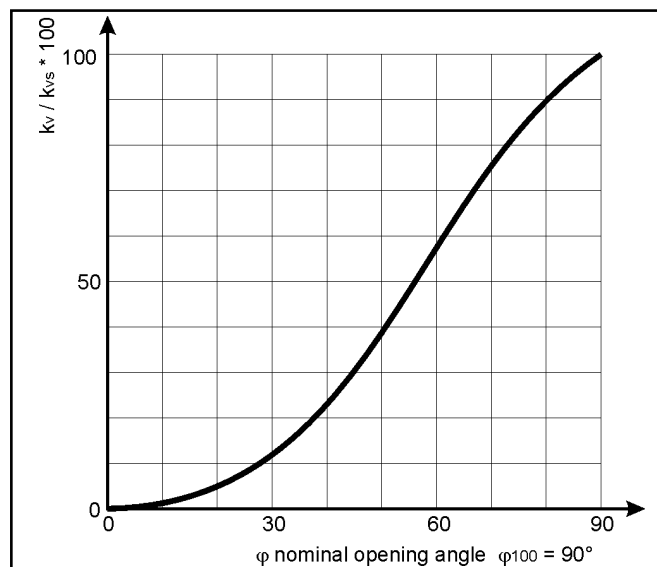

Fig. 7 - Characteristic curve

Dimensions and weights:

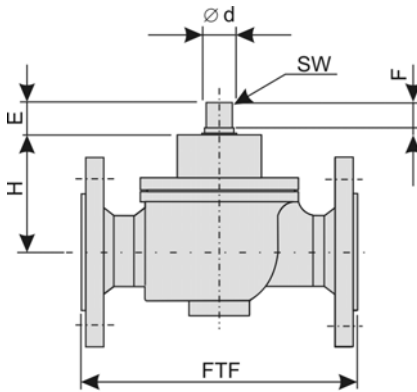

Fig. 8 - Rotary Plug Valve

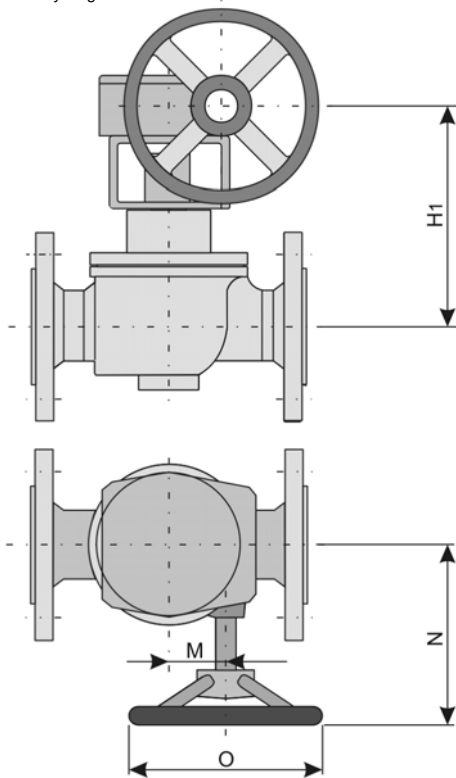

Fig. 9 - Rotary Plug Valve with Hand-operated actuator

DN	25	50	80	100	150
FTF	160	230	310	350	480
E	19	19	23	23	31
F	12	12	16	16	24
$\varnothing d$	16	20	24	28	36
H	81	99	127	134	205
SW	12	12	16	16	24
DIN ISO Connection	F05	F07	F07	F07	F10
Weight Rotary plug valve	5	13	26	35	120

H1	170	200	220	230	315
M	45	45	45	45	45
N	150	150	150	150	150
O	200	200	200	200	200
Weight Gear box	3	3	3	3	3

Table 8 - Dimensions in mm and weights in kg

Selecting and sizing the rotary plug valve:

1. Calculate the appropriate kv value.
2. Select the nominal size and the kvs value from Table 7.
3. Comparing the operation conditions in accordance to the pressure-temperature diagram.
4. Select a suitable actuator from Table 6.
5. Additional equipment

Ordering text:

Rotary Plug Valve Series 23b,
 DN / PN , optional special version
 Manual gear actuator or actuator (brand name):
 Supply pressure: bar, fail-safe position:
 Limit switch (brand name):
 Solenoid valve (brand name):
 Positioner:
 Others:



Note: All relevant details regarding the version ordered, which deviate from the specified version in this technical description data, can be taken if required, from the corresponding order confirm.

Please contact our technical sales team for your special requirements

Pfeiffer Chemie-Armaturenbau GmbH

Hooghe Weg 41 • 47906 Kempen • Germany

Phone: +49 2152 2005-0 • Telefax: +49 2152 1580

E-Mail: vertrieb@pfeiffer-armaturen.com • Internet: www.pfeiffer-armaturen.com

Specifications subject to change without notice.