

Stainless steel Ball valve Series 26a with live - loaded sealing system

Application:

Tight-closing ball valve produced from anti-corrosive material for aggressive media, especially with high process demand in chemical plants:

- Nominal sizes 1/2" to 8" and DN 15 to DN 200,
- Nominal pressures ANSI 150/300 lbs and PN 16, 25, 40,
- Temperatures 14°F to 392°F (-10°C to 200°C).

The control equipment consists of a ball valve and a pneumatic quarter-turn actuator or a hand lever. The valves, which are of modular construction have the following features:

- Seating live-loaded at one side.
- "Open-Close" operation with particularly low leak rate "bubble-tight version".
- Valve body, ball and shaft made of stainless steel, nickel, titanium and other anti-corrosive materials.
- Exchangeable bore seal in TFM.
- Stem sealing by means of a cup spring live-loaded packing.
- Blowout-proof stem.
- Face to face dimensions serie 1 acc. to EN 558-1 and acc. to ASME B16.10-200.
- Attachment options acc. to DIN ISO 5211.

Versions:

Series 26a Ball valve optionally available in the following versions:

- ball valve with hand lever
- ball valve with Manual gear actuator,
- ball valve with pneumatic quarter-turn actuator, (for details see respective data sheet).

Special designs:

- Control ball valve due to characteristic seating.
- Body and further components in special material (e.g. monel, hastelloy).
- Seating not live-loaded.
- Metallic seating.
- Heating jacket in steel or stainless steel.
- Double stuffing box with leakage detecting connection.
- Flange groove according to DIN EN 1092.
- Fire-safe version with test certificate according to British Standard B.S. 6755 Part 2.
- High temperature version.

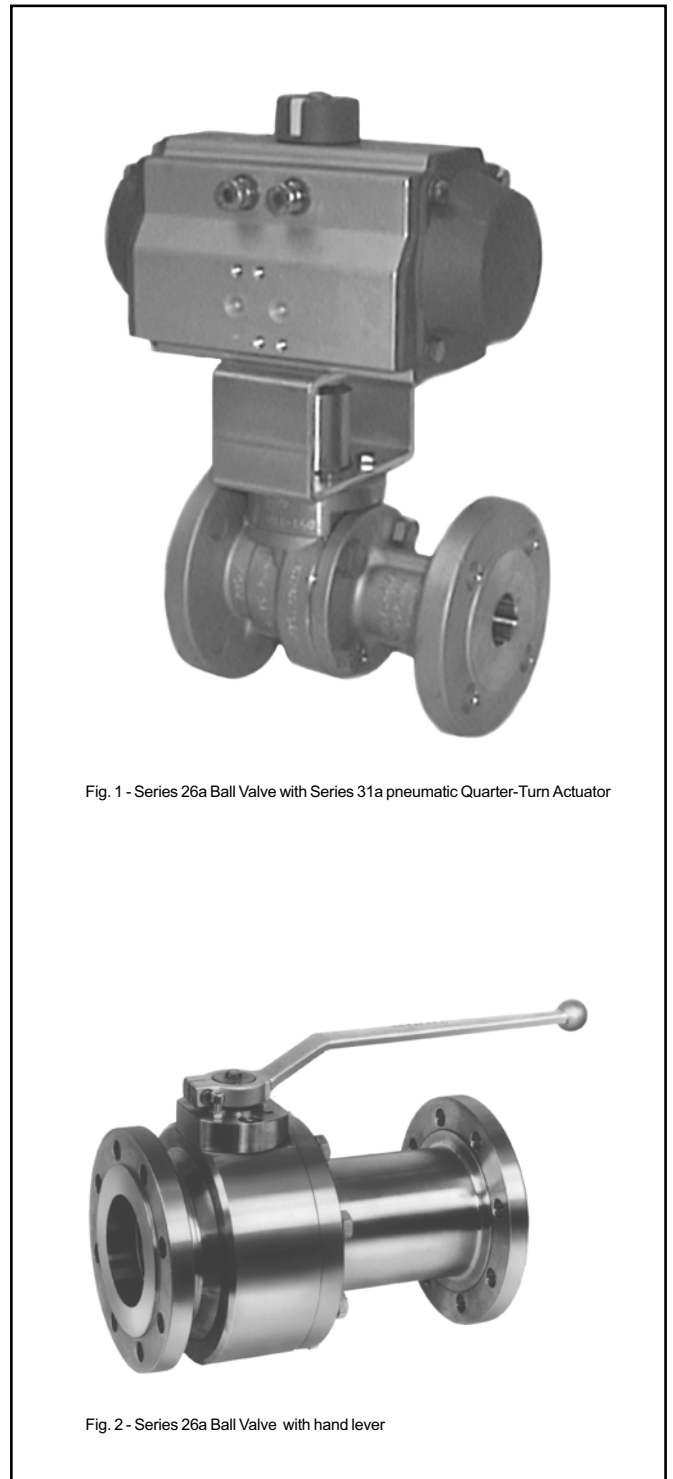

Fig. 1 - Series 26a Ball Valve with Series 31a pneumatic Quarter-Turn Actuator

Fig. 2 - Series 26a Ball Valve with hand lever

Ball valve Series 26a

Additional equipment and add-on pieces:

For the control valves, the following accessories are available either individually or in combination:

- Extension to stem (100mm).
- Pneumatic and electric quarter-turn actuators.
- Exchangeable pneumatic quarter-turn actuator which can be equipped with limit switches and solenoid valves.
- Positioner (with optional control ball valve).
- Limit switches.
- Solenoid valves.
- Filter regulator.

Further accessories are available on request for customer specifications

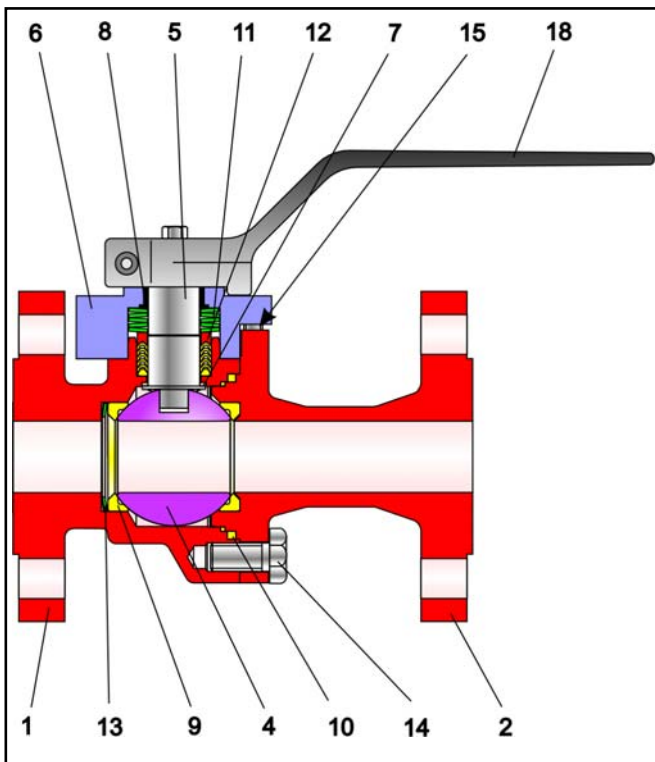
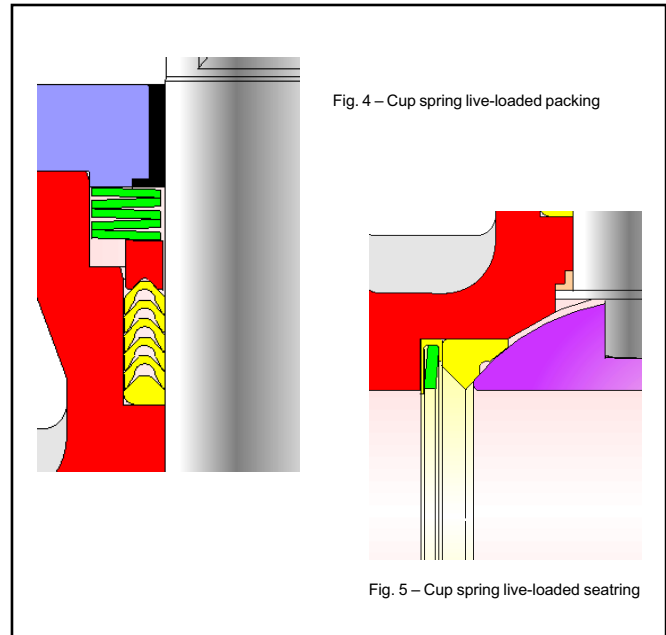

Fig. 3 – Sectional diagram of Series 26a Ball Valve

Pos.	Description	Pos.	Description
1	Main body	11	Set of spring washers
2	Side body	12	V-ring packing
4	Ball	13	Spring washer
5	Control shaft	14	Screw
6	Stuffing box flange	15	Screw
7	Bearing bushing	16	Nut
8	Bearing bushing	17	Screw
9	Set of sealing rings	18	Hand lever
10	Body sealing		

Table 1 - Parts list

Advantages of the cup spring live-loaded sealing system:



- maintenance-free and self-adjustable,
- two active seatings,
- highest level of tightness, even under extreme pressure and temperature fluctuations,
- longer service life,
- reduced increase in torque at increasing temperatures, therefore requiring smaller actuators for automation,
- **all in all: extremely economic!**

Principle of operation:

The ball valves of the series 26a permit full flow through the valve in either direction.

The ball (4) with its cylindrical passage rotates around the middle axis.

The opening angle of the ball determines the flow through the free area between the body (1) and passage.

The stem is externally equipped with a hand-lever (18). Optionally, a pneumatic actuator or gear operator can be fitted.

The sealing of the ball (4) is provided by exchangeable seat rings (9).

The ball stem is sealed by a PTFE V-ring-packing (12). The live-loading is carried out by cup springs (11) positioned above the packing.



Note: The ball valve series 26a also can be used for controlling applications. Please pay attention to the technical data sheet <DB 20a-kd>.



Note: Please, pay attention to the usability acc. to the ATEX 94/9/EG in correspondance to the maintenance sheet before using the ball valve in hazardous area!



Failure position: In dependance of mounting position of the actuator there are two failure positions, wich take place by pressure relieving or on failure of air supply:

- **Ball valve with actuator “ on failure closing “**
on failure of air supply the ball valve closes. The opening of the ball valve accures on rising of air supply against the force of the springs.
- **Ball valve with actuator “ on failure opening “**
on failure of air supply the ball valve opens. The closing of the ball valve accures on rising of air supply against the force of the springs.

General technical data:

Nominal size	1/2" to 8" as well as DN 15 to DN 200
Nominal pressure	ANSI 150 / 300 lbs and PN 16, 25, 40 bar
Temperature range	14°F to 392°F (-10°C to 200°C)
Ball sealing	TFM (PTFE)
Leakage rate	Leakage rate A acc. to DIN EN 12266-1, P12 (Leakage rate 1 BO acc. to DIN 3230 Part 3)
Flanges	acc. ASME B16.34 and B16.5 and DIN EN 1092
Stuffing box packing	live-loadet PTFE - V-ring packing

Table 2 - technical data

Materials:

Main body	A351 CF8M / A182 F316 (1.4408 / 1.4571)
Side body	A351 CF8M / A182 F316 (1.4408 / 1.4571)
Ball	1.4408 / WN 1.4571
Control shaft	1.4571
Seat rings	TFM (PTFE)
Spring washer	1.4404 encapsulated in pure PTFE
V-ring packing	PTFE - V-ring-packing loaded by Belleville washers (1.8159)
upper Bearing bushing	PTFE with 25% glass
lower Bearing bushing	PTFE with 25% carbon
Body sealing	PTFE

Table 3 - Materials

Optional material combinations:

- Stem and ball on request.
- Seatrings in PTFE compounds.
- Metallic seating.
- Sealing in graphit.

Pressure-Temperature diagram:

The area of application is determined by the pressure-temperature diagram. Process data and the process medium can affect the values in the diagram.

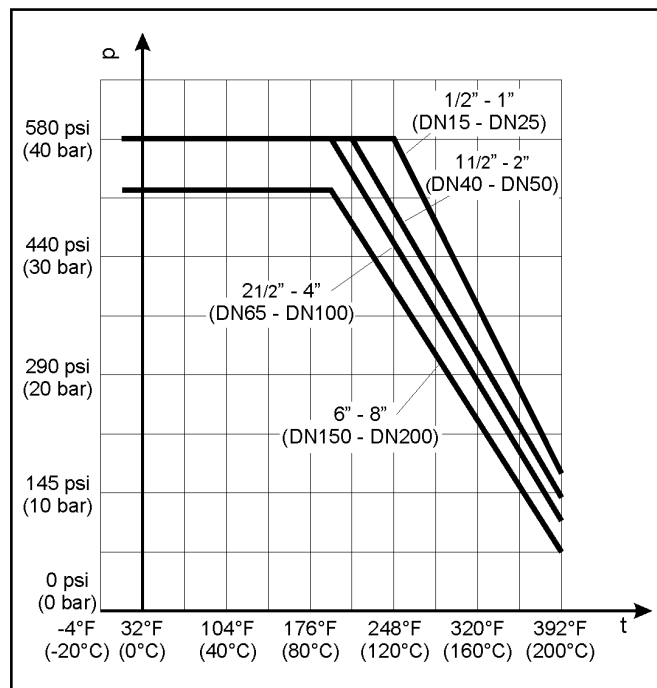

Fig. 6 - Pressure-Temperature diagram

Torque and breakaway torques:

DN	Differential pressure		Δp in bar											
	Δp in bar	Δp in psi	0	2	4	6	8	10	16	25	40			
15 1/2"	80	176	4	6	6	7	7	8	9	11	14			
25 1"	168	369	7	10	10	11	12	13	14	17	21	28		
40 1 1/2"	182	400	14	20	22	24	27	29	32	39	50	68		
50 2"	226	497	17	25	28	32	36	40	43	55	71	100		
65 2 1/2"	437	961	42	60	66	72	79	85	91	110	139	186		
80 3"	437	961	49	70	79	89	98	108	118	146	190	262		
100 4"	749	1647	77	110	125	140	155	170	185	230	297	-		
125 5"	898	1975	119	170	187	219	244	269	294	368	480	-		
150 6"	1497	3293	161	230	263	297	330	364	398	498	650	-		
200 8"	1497	3293	280	400	440	516	574	633	692	866	-	-		

Table 4 - max. permissible torque, required torque and breakaway torque

The breakaway torques specified are average values which were measured with air at 20°C with the corresponding differential pressures. Operating temperature, process medium and long operating times may affect the permissible torques and breakaway torques considerably.

Dimensions and weights:

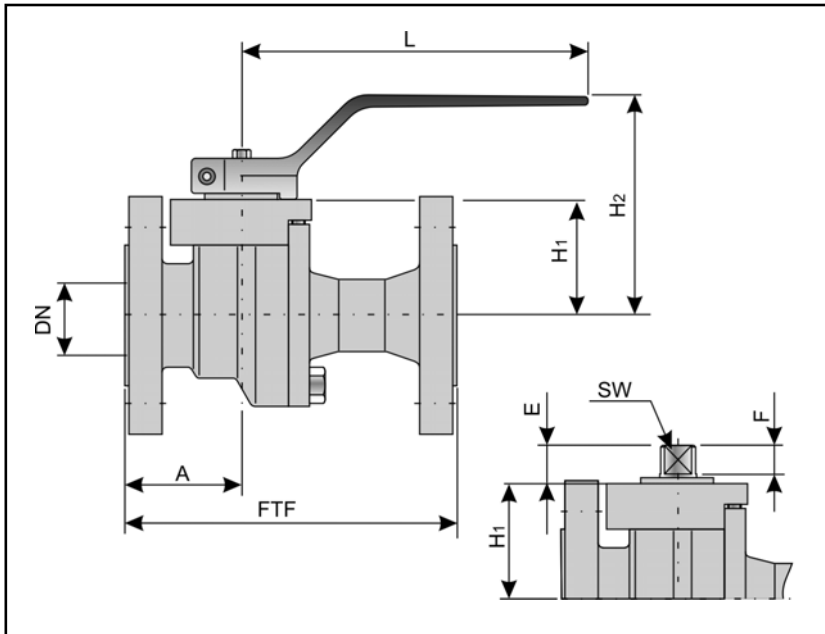

Fig. 7 - Dimensional drawing

DN	15 / 1/2"	25 / 1"	40 / 1 1/2"	50 / 2"	65 / 2 1/2"	80 / 3"	100 / 4"	125 / 5"	150 / 6"	200 / 8"	
FTF (DIN)	series 1	130	160	200	230	290	310	350	400	480	600
	series 27	-	-	-	150	170	180	190	325	350	400
FTF (ANSI)	class 150	108	127	165	178	190	203	229	356	394	457
	class 300	140	165	191	216	241	283	305	381	403	502
A	54	56	59	65	75	85	98	120	165	190	
H1	47	58	72	73	95	110	126	180	180	229	
H2	113	124	136	137	163	178	194	246	-	-	
L	144	144	207	207	350	350	350	350	-	-	
E	13	19	19	19	23	23	27	31	37	37	
F	8	12	12	12	16	16	20	24	30	30	
SW	9	12	12	12	16	16	20	24	30	30	
DIN ISO Connection	F03	F05	F05	F05	F07	F07	F07	F10	F14	F14	
Weight in kg	3	6	12	15	28	30	48	72	110	195	

Table 5 - Dimensions in mm and weights in kg

Selection and sizing of the ball valve:

1. Calculation of the required nominal diameter
2. Selection of the valve in accordance with table 2, table 3 and the Pressure-Temperature diagram
3. Selection of the appropriate actuator with the assistance of table 4
4. Additional equipment

Ordering text:

Ball valve in stainless steel Series 26a,
DN / PN , optional special version

Manual gear actuator
or actuator (brand name):
Supply pressure: bar
fail-safe position:

Limit switch (brand name):
Solenoid valve (brand name):
Positioner:

Others:



Note: All relevant details regarding the version ordered, which deviate from the specified version in this technical description data, can be taken if required, from the corresponding order confirm.

For your special requirements please contact our technical sales department.

Pfeiffer Chemie-Armaturenbau GmbH

Hooghe Weg 41 • 47906 Kempen

Telefon: +49 21 52 20 05 - 0 • Telefax: +49 21 52 15 80

E-Mail: vertrieb@pfeiffer-armaturen.com • Internet: www.pfeiffer-armaturen.com

Values subject to change