

# Control Valve made of special metals Series 40a / Series 41a

## Application:

Tight-closing globe control valve produced from anti-corrosive material for severely aggressive or corrosive media, especially for chemical processes:

- Nominal sizes DN 15 to DN 150 as well as 1/2" to 6"
- Nominal pressure PN 10 to 160 and ANSI Class 150 to 1500 lbs
- Temperatures depending on version from -40°C to 400°C

The control valve consists of a single-seated globe valve and either a pneumatic actuator or hand operated actuator.

The valve is designed according to the modular-assembly principle and has the following features:

- Stem sealing with metal bellows and backup packing, **Series 40a** with double packing, **Series 41a**
- Streamlined valve body.
- Exchangeable PTFE seat and PTFE plug.
- Test connection for monitoring of the bellow primary seal.
- Exchangeable actuator.
- Additional equipment can be added in acc. to DIN EN 60534 and Namur recommendations.
- Face-to-face dimensions for DIN version acc. to DIN EN 558-1, Series 1.
- Face-to-face dimensions for ANSI version acc. to DIN EN 558-2, Series 1.

## Versions:

The Series 40a / 41a Globe Valve is available optionally in the following versions:

- Samson pneumatic actuator (Fig. 1).
- Samson hand-operated actuator.
- Actuators of other manufacturers on request.

## Special designs:

- Tracement: valve body with heating jacket.
- Bellows and Plug stem made of special material (e.g. hastelloy).
- Guided V-port plug
- Flange Groove acc. to DIN EN 1092.



Fig. 1 - Series 1a Control Valve with Samson actuator

# Control Valve Series 40a / 41a

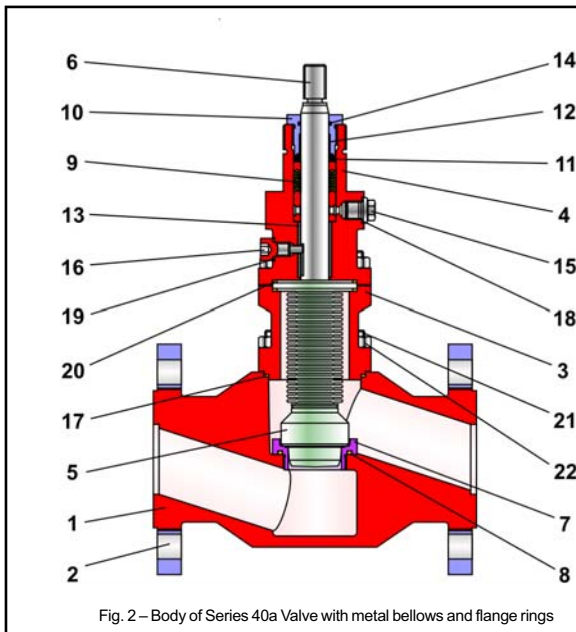

Fig. 2 – Body of Series 40a Valve with metal bellows and flange rings

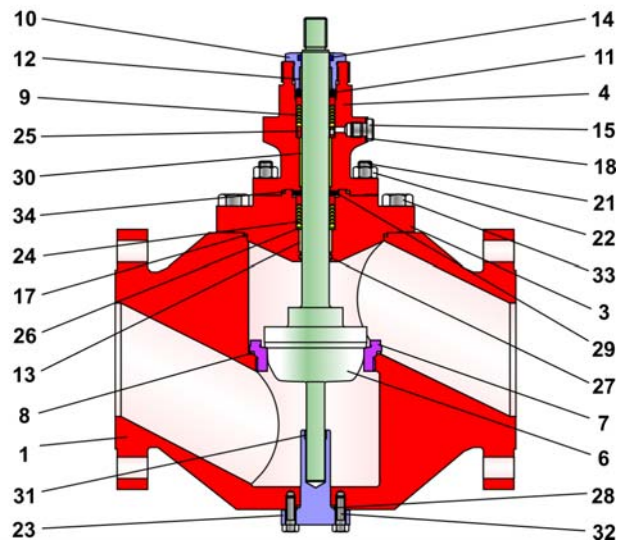

Fig. 3 – Body of Series 41a Valve with safety packing and bottom stem guide

Item	Description	Item	Description
1	Valve body	16	Locking screw
2	Flange ring	17	Body sealing
3	Intermediate flange	18	Gasket
4	Bonnet flange	19	Gasket
5	Plug with Bellows (Series 40a)	20	Gasket
		21	Screw
	Plug without Bellows (Series 41a)	22	Nut
6	Spindle	23	Trunnion
7	Seat	24	V-ring packing
		25	Distance bushing
8	O-ring	26	Washer
9	V-ring packing	27	O-ring
10	Stuffing box	28	PTFE-ring
11	Set of Belleville washers	29	Set of Belleville washers
12	Bearing bushing	30	Bearing bushing
13	Bearing bushing	31	Bearing bushing
14	O-ring	32	Screw
15	Locking screw	33	Screw
		34	Body sealing

Table 1 - List of parts

## Principle of operation:

The process medium flows through the valve in the flow-to-open direction. The position of the plug determines the cross-sectional area of flow between the plug and seat ( 7 ). The plug is connected over the stem ( 6 ) to the actuator stem.

The metal bellows ( 5 ) seals the **Series 40a** Valve between the valve body and the stem.

The packing ( 9 ) is used as an additional stem sealing. A test connection port ( 15 ) allows the bellows ( 5 ) to be monitored for leakage, e.g. by connecting a suction line or inert gas line.

The stem of the **Series 41a** Valve is sealed by a V-ring packing live-loaded by Belleville washers ( 24 and 29 ). The double packing ( 9 and 11 ) serves as an additional stem sealing.

Its sealing performance can also be monitored in conjunction with a test connection port ( 15 ).



**Note :** In the event that cavitation may occur, we recommend the use of a guided plug for differential pressures over 3 bars and differential pressure ratio  $p_2 < \Delta p$ , !



**Note:** Before using the valve in hazardous areas, check whether this is possible according to ATEX 94/9/EG by referring to the Operating Instructions < BA 40a >.



**Fail-safe position:** Depending on how the pneumatic actuator is mounted to the valve, the valve has two fail-safe positions which become effective when the air pressure in the actuator is relieved or when the supply air fails:

- **Control valve with actuator “ Spring closes “**  
Upon air failure, the valve is closed. The valve opens when the signal pressure increases, acting against the force of the springs.
- **Control valve with actuator “ Spring opens “**  
Upon air failure, the valve is opened. The valve closes when the signal pressure increases, acting against the force of the springs.

### Additional equipment and add-on pieces:

For the control valves, the following accessories are available either individually or in combination:

- Positioner
- Limit switch
- Solenoid valves
- Supply air pressure regulator/filter
- Pressure gauge mounting blocks

Further accessories are available on request for customer specifications

### General Technical Data:

Nominal size	DN 15 to DN 150 and 1/2" to 6"
Nominal pressure	PN 10 to 160 and Class 150 to 1500 lbs
Temperature range	Depending on valve version
Characteristic	Equal percentage / linear
Leakage rate	Leakage rate A acc. to DIN EN 12266-1, P12 (Leakage rate 1 BO acc. to DIN 3230 Part 3)
Rangeability	30 : 1 / 50 : 1
End connections	All DIN and ANSI dimensions

Table 2 – technical data

### Materials:

Body	Corrosion-resistant materials on request
Valve plug and seat	
Bellows	
Spindle	
Packing	PTFE V-ring packing, live-loaded with stainless steel Belleville washers

Table 3 - materials

### Permissible differential pressures $\Delta p$ :

Signal pressure range			0.2...1.0 (0.2..0.8)	0.3...1.1	0.4...1.2 (0.4..1.0)	0.4...2.0 (0.4..1.6)	0.6...3.0 (0.5..1.7)	0.2...1.0 (0.4...1.0)		
Required supply pressure			1.3	1.4	1.4	2.3	3.3	1.2	1.4	1.6(1.5)
DN	Seat $\phi$ in mm	Actuator in cm <sup>2</sup>	$\Delta p$ with $p_2 = 0$							
25 / 1"	2	240	> 16	-	-	-	-	> 16	-	-
	6	240	> 16	-	-	-	-	> 16	-	-
	13	240	8.0	> 16	-	> 16	-	8.0	> 16	-
	24	240	-	3.5	-	7.6	15.8	-	7.6	15.8
		350	3.2	-	15.2	15.2	-	3.2	15.2	-
40 / 1 1/2"	30	240	-	1.1	-	3.9	9.3	-	3.9	9.3
		350	0.9	-	8.9	8.9	> 16	0.9	8.9	-
50 / 2"	38	240	-	-	-	1.5	4.9	-	1.5	4.9
		350	-	-	4.7	4.7	9.7	-	4.7	9.7
80 / 3"	55	700	1.2	-	5.2	5.2	-	1.2	5.2	-
80-100 / 3"-4"	65	700	0.5	-	4.1	4.1	7.7	0.5	4.1	7.7
100 / 4"	85	700	-	-	1.9	1.9	4.0	-	1.9	4.0
150 / 6"	110	1400	(0.7)	-	(3.3)	(3.3)	(4.6)	(0.7)	(3.3)	(4.6)
	120	1400	(0.5)	-	(2.7)	(2.7)	(3.7)	(0.5)	(2.7)	(3.7)

Table 5a - Valves with spring closing actuator  
Valve with signal pressure 0 bar closed.

Table 5b - Valves with spring opening actuator  
Valve with required signal pressure closed..

The shaded columns of the table show the standard values. The differential pressures in the white columns of table 5a apply to pre-loaded springs. The values in brackets in the column "control pressure range" refer to the differential pressure values in brackets. The permissible differential pressures quoted are only valid for soft-sealing valves.

### z-values depending on kvs-value and nominal sizes:

DN	25 / 1"				40 / 1 1/2"		50 / 2"		80 / 3"		100 / 4"		150 / 6"	
Seat- $\phi$ in mm	2	6	13	24	30	38	55	65	65	85	110	120		
Travel in mm	15						30						30 / 45	
kvs	Cv	Acoustical valve coefficient z												
0.005	0.006	0.85												
0.01	0.01													
0.05	0.06													
0.1	0.12	0.65												
0.25	0.29													
0.63	0.74													
1.0	1.17													
1.6	1.9	0.6												
2.5	2.9													
4	4.7		0.55		0.55									
6.3	7.4			0.45	0.5	0.5								
10	12			0.4	0.45	0.45								
16	19				0.4	0.4	0.45							
25	29					0.35	0.4		0.4					
40	47						0.35		0.35		0.4			
63	74							0.3		0.3	0.35			
80	94								0.25	0.25	0.3			
100	117									0.25	0.3			
125	146										0.2	0.2		
150	175											0.2		
260	304												0.2	

Table 4 – acoustically determined valve parameter "z" in acc. with VDMA



### Note:

Trims with guided plugs partly have reduced kvs value

### Terms for noise level calculation:

according to VDMA 24422. z = acoustical valve coefficient.

### Terms for control valve sizing:

according to DIN EN 60534-2-1:

$$FL = 0,95 \quad xT = 0,75$$

### Correction terms:

For gases and vapours :  $\Delta LG = 0$ ,

For liquids:  $\Delta LF = 0$

**Dimensions and weights:**

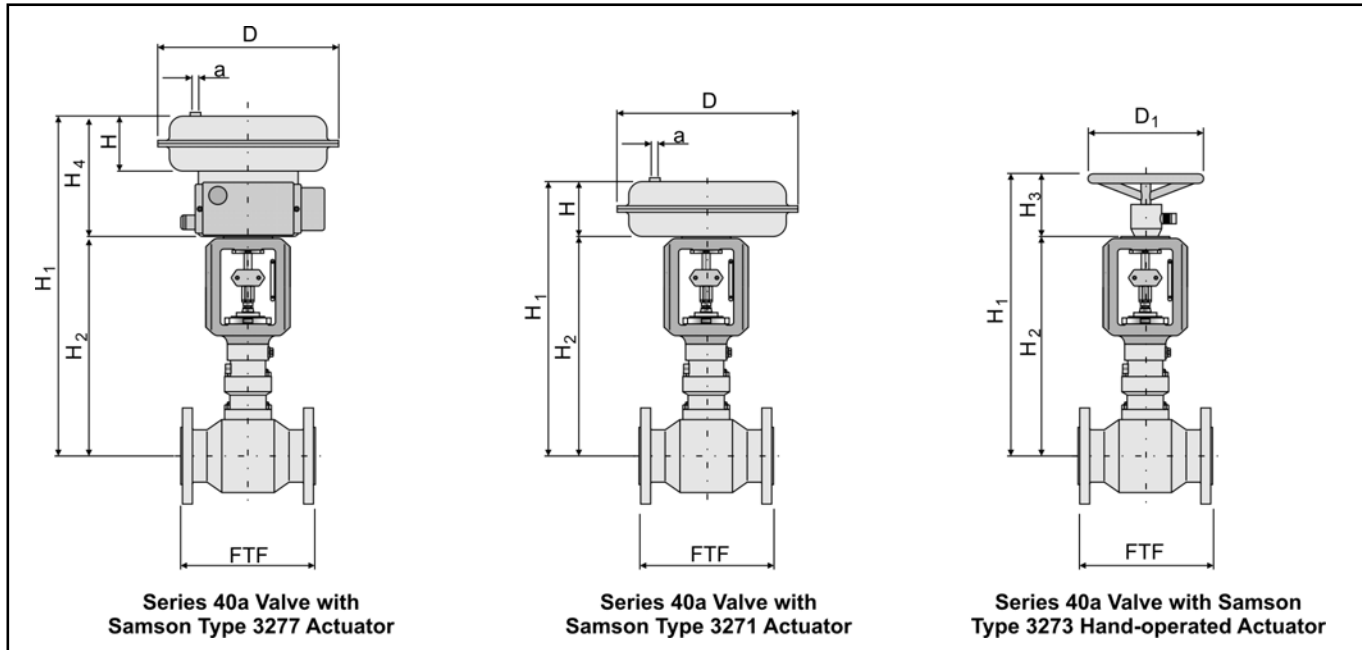

Fig. 5 – dimensional drawing

DN	15 / 1/2"	20 / 3/4"	25 / 1"	32 / 1 1/4"	40 / 1 1/2"	50 / 2"	80 / 3"	100 / 4"	150 / 6"
FTF Series 1	130	150	160	180	200	230	310	350	480
H1	Depending on valve body style and version on request								
Actuator	240cm <sup>2</sup>	x	x	x	x	x			
	350cm <sup>2</sup>		x	x	x	x			
	700cm <sup>2</sup>					x	x	x	x
	1400cm <sup>2</sup>								x
D1	180	180	180	180	180	180	250	250	250
H3	110	110	110	110	110	110	115	115	115
Weight Type 3273 in kg	2	2	2	2	2	2	2.5	2.5	2.5
Actuator in ccm		240		350		700		1400	
		240		280		390		530	
H		65		85		135		197	
H4		166		186		236		-	
a		G1/4"			G3/8"				
Weight Actuator Type 3271 in kg		5		8		22		70	
Weight Actuator Type 3277 in kg		9		12		26		-	

Table 6 - dimensions in mm and weights in kg



**Note:** All relevant details regarding the version ordered, which deviate from the specified version in this technical description data, can be taken if required, from the corresponding order confirm.

**Selection and sizing of the control valve:**

1. Calculation of the appropriate kvs-value in acc. with DIN EN 60534
2. Selection of DN and kvs-value in acc. with table 4
3. Determination of the Dp occurring, selection of the appropriate actuator in acc. with tables 5a and 5b.
4. Checking the application in view of the pressure-temperature diagram.
5. Additional equipment

**Order text:**

Series 40a/41a Control Valve,  
 DN....., PN....., kvs .....

Basic characteristic curve: equal percentage / linear  
 Body: .....  
 Flange design: .....  
 Special design  
 Actuator: Samson Type.....,..... cm<sup>2</sup>,  
 Control pressure range : ..... bar,  
 Connection of a pneumatic / electro-pneumatic positioner,  
 a pneumatic / electric limit switch and / or a solenoid valve

**Please contact our technical sales team for your special requirements**

## Pfeiffer Chemie-Armaturenbau GmbH

Hooghe Weg 41 • D 47906 Kempen  
 Phone: +49 2152 2005 - 0 • Fax: +49 2152 1580  
 E-mail: vertrieb@pfeiffer-armaturen.com • Internet: www.pfeiffer-armaturen.com

**Specifications subject to change without notice.**