

# Maintenance and repair instructions

## Butterfly valve Series 14a



Fig 1 - Control- and shut off butterfly valve, Series 14a



This equipment may only be dismantled and disassembled by skilled personal, who are familiar with the assembly, start-up and operation of this product.

Skilled personal in the sense of these repair and assembly instructions are persons, who as a result of their training, experience and knowledge of the relevant standards, are able to judge the tasks assigned to them, and to reconise possible dangers.

### 1. Design, operation and dimensions

Design, operation and dimensions, also all further technical details can be found in the **Data sheet** < TB 14a\_EN >.

### 2. Installation, start-up and maintenance

Guidelines for the installation, start-up and maintenance can be found in the **Operating instructions**.

< BA 14b-01\_EN > for automatic butterfly valves, i.e.

< BA 14b-02\_EN > for manually operated valves.

### 0. Introduction

These instructions are intended to support the user in the assembly and repair of control- and shut-off valves for series 14a.

Technical details, as a result of further development of the valves mentioned in these instructions are subject to modification without notice.

The text and illustrations do not necessarily display the scope of supply, or an eventual order of spare parts. Drawings and graphics are not to scale. Customer related designs, which are not in accordance with our standard offer are not shown.

The transfer of these instructions to third parties is only allowed with written approval of Pfeiffer Chemie-Armaturenbau GmbH. All documents are protected according to the laws of the German Copyright Act. The transmission and / or duplication of documents, even in abstracts, also the exploitation and communication of contents is not permitted unless expressly granted.

Violations are an offence and liable to claims for damages. We reserve all rights for the exercise of industrial property rights.

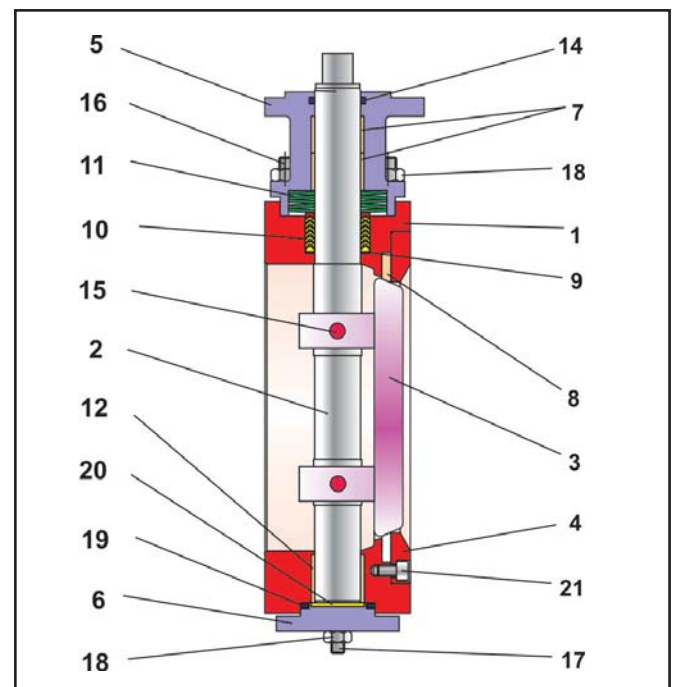

Fig 2 - Sectional view of a butterfly valve, Series 14a => Parts list, see page 2

# Control - Shut-off valve Series 14a

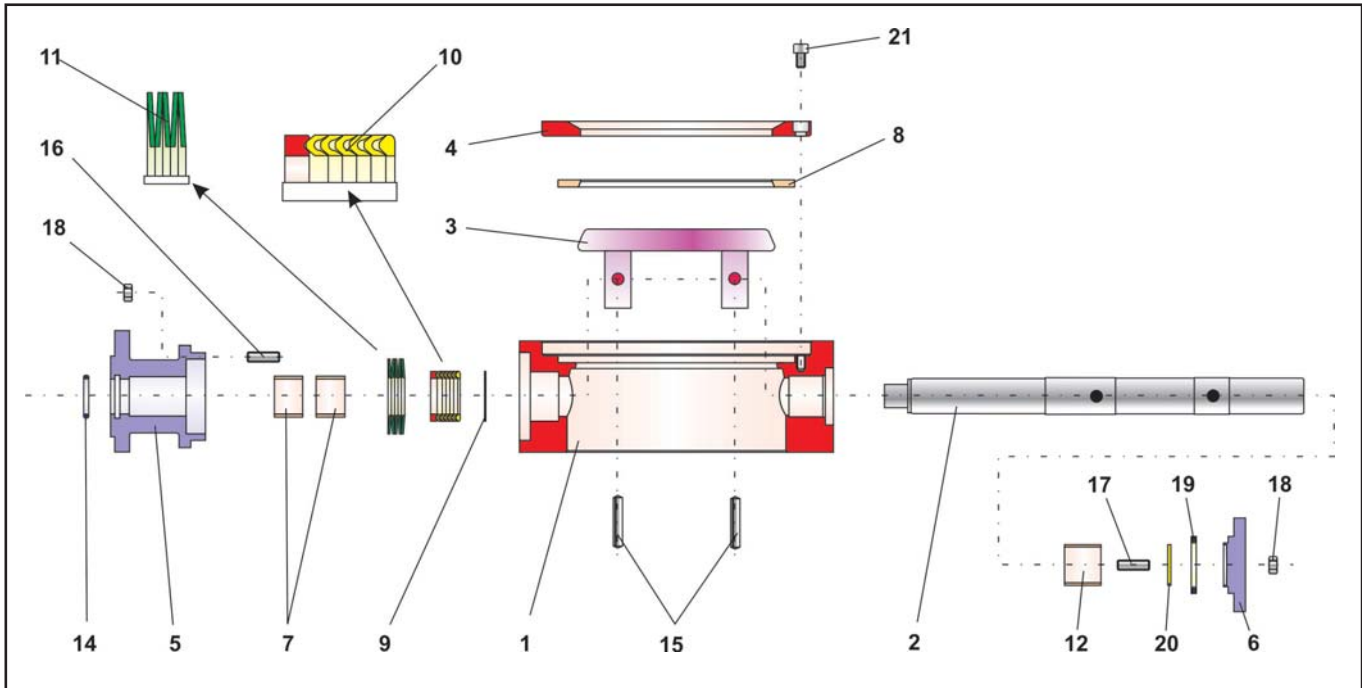

Fig 3 - Explosion drawing of butterfly valve, Series 14a

Pos.	Description	Material
1	Body	1.4581
2	Shaft	1.4571
3	Disc	1.4581
4	Mounting ring	1.4581
5	Bonnet flange	1.4571
6	Bonnet	1.4571
7	Bearing bush	Glycodur
8	Sealing ring	PTFE with glass
9	Thrust washer	1.4571
10	V-ring packing	1.4305 / PTFE
11	Spring washer set	1.8159 / Delta Tone
12	Bearing bush	PTFE with glass
14	O-ring	Viton
15	Grooved pin	DIN 1472, 1.4571
16	Stud screw	DIN 938, A2-70
17	Stud screw	DIN 938, A2-70
18	Hexagon nut	DIN 934, A2-70
19	Body sealing	PTFE / Viton
20	Counter washer	PTFE
21	Cylinder head screw	DIN 912, A2-70

Table 1 - Parts list

## 3. Assembly of the Butterfly valve

### 3.1 Preparation for assembly

To assemble the butterfly valve, first clean all parts thoroughly, and lay them carefully on a soft padded surface ( rubber mat or similar. )

Take into consideration, that parts made of plastic are generally soft and sensitive, in particular the sealing surfaces must be handled with care and not be damaged.



**Attention:** To avoid cold corrosion of the screws in the bodies, the manufacturer has used a high performance lubricating grease (i.e. Gleitmo 805. from Fuchs).

This grease however may not be applied to valves, which are used in an oxygen environment. Valves which must be free of grease, especially for use in oxygen, an appropriate lubrication must be used.



**Note:** The position and arrangement of the individual parts shown in the explosion drawing (Fig 3) must be observed when assembling the valve.

### 3.2 Pre-assembly of the bonnet flange

The bonnet flange ( 5 ) is placed with shaft opening surface facing downwards, and positioned for easy working access.

With means of a mandrel, the glycodur-sleeves ( 7 ) are placed in the shaft opening.

To continue the assembly, the bonnet flange is placed on the flange side, so the top opening is accessible.  
Insert the O-ring ( 14 ) in the recess of the bonnet flange ( 5 ).

### 3.3 Pre-assembly of the Butterfly disc

The disc body ( 1 ) is placed with sealing side on a clean surface, and positioned for easy working access to the bearing area of the shaft.

The bearing bush ( 12 ) is placed over the shaft and pressed as far as possible into the bore bearing in the body ( 1 ).

The stud screws ( 17 ) are screwed into the body.  
The body sealing ring ( 19 ) is pressed onto the bonnet ( 6 ).  
Place the washer ( 20 ) in the intended recess in the bonnet.

Insert the pre-assembled bonnet in the bore bearing, align the bonnet with stud screws.  
Now tighten the bonnet with the nuts ( 18 ) evenly and in alternating pattern.

The butterfly disc ( 3 ) is placed in the body, so that the bearing bores of the disc are aligned with the bearing bores of the body .



**Note:**  
Pay attention to the eccentricity of the butterfly disc.

Now, guide the shaft ( 2 ) through the bearing bore of the body and the disc.

Push the thrust washer ( 9 ) over the shaft end, and press into the respective position in the body ( 1 ).  
The PTFE - V-ring packing ( 10 ) is placed over the shaft, and with a mounting sleeve pressed into the bore of the body. Refer to the explosion drawing ( Fig 3 ) for positioning the V-ring packing.

Push the spring washer set ( 11 ) over the shaft and place in respective position on the packing. Refer also the explosion drawing ( Fig 3 ) for positioning the spring washers.

Screw the stud screws ( 16 ) in the body.

The pre-assembled bonnet flange ( see section 3.2 ) is carefully pushed over butterfly disc onto the body, align with the stud screws. Now tighten the bonnet with the nuts ( 18 ) evenly and in alternating pattern.

Now turn the body 180° so the sealing surface is facing upwards.

The butterfly disc aligns, when the disc is rotated in the body in clockwise direction.



**Attention:**  
Do not damage the sealing surfaces

The flats of the shaft are positioned parallel to the butterfly disc and then secured to prevent further turning.



**Note:** Make sure, that the shaft is against the counter washer ( 20 ).

To connect the shaft and the disc together, drill fitting bores, following this, the disc and shaft are fitted with dowel pins. ( 15 )

### 3.4 Final assembly of the butterfly disc der

Turn the butterfly disc in the „Closed“ position.  
Now insert the sealing ring ( 8 ) in the body.



**Attention:**  
Cleanliness is very important.

The mounting ring ( 4 ) is placed on the sealing ring, and is aligned with the screws ( 21 ). Following this, the screws are tightened evenly and in alternating pattern.

### 3.5 Notice for attaching actuator elements



**Attention:** The closed position for double eccentric control valves is always with the shaft in a clockwise rotation of the valve shaft!

It is therefore important to observe the direction of rotation when attaching the actuator!

A label plate on the butterfly control valve indicates the direction of rotation.

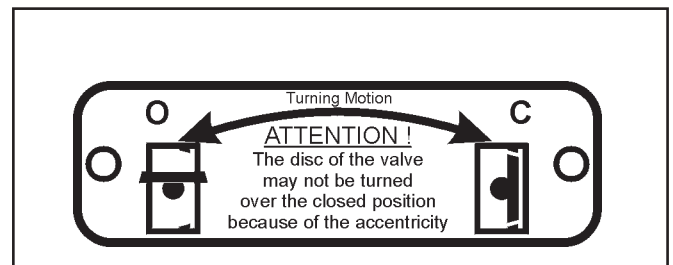

Fig 4 - Indicating plate for the direction of rotation

**The assembly of the valve is now completed.**

## 4. Malfunction and their elimination

Assistance in the case of malfunction is provided in the **Operating instructions**

< BA 14b-01\_EN > for automatic butterfly valves, i.e.

< BA 14b-02\_EN > for manually operated butterfly valves, under section 7.

## 5. Repairing the butterfly valve

### 5.1 Replacing the V-ring packing

If leakage is located at the shaft-lead through of the disc, the V-ring packing ( 10 ) may be defect.

It is therefore recommended to check the condition of V-ring packing.

To dismantle the V-ring packing, proceed in reverse order as described in section 3.

As with all other plastic parts, check the PTFE-packing rings for damage, and if necessary replace these parts.

### 5.2 Replacing the sealing rings

If leakage is located at the through flow of the disc, the sealing ring ( 8 ) may be defect.

It is therefore recommended to check the condition of the sealing ring.

To dismantle the sealing ring, proceed in reverse order as described in section 3.

As with all other plastic parts, check the sealing ring for damage, and if necessary replace these parts.

### 5.3 Further repair work

In case of further more serious damage, we recommend the repair work to be carried out in our factory by our skilled staff.

## 6. Customer inquiries

( bei Rückfragen bitte angeben )

1. Commission nummer ( embosed on type plate)
2. Type, manufacturing no., nominal diameter and control valve version.
3. Pressure and temperature of the media flow.
4. Through flow in m<sup>3</sup>/h
5. Possible circuit diagram.

For your special requirements, please contact our technical sales department.

**Pfeiffer Chemie-Armaturenbau GmbH**

Hooghe Weg 41 • 47906 Kempen

Telefon: 02152 / 2005-0 • Telefax: 02152 / 1580

E-Mail: [vertrieb@pfeiffer-armaturen.com](mailto:vertrieb@pfeiffer-armaturen.com) • Internet: [www.pfeiffer-armaturen.com](http://www.pfeiffer-armaturen.com)

Specifications and versions are subject to change without notice