

Maintenance

Globe Control Valve Series 1a

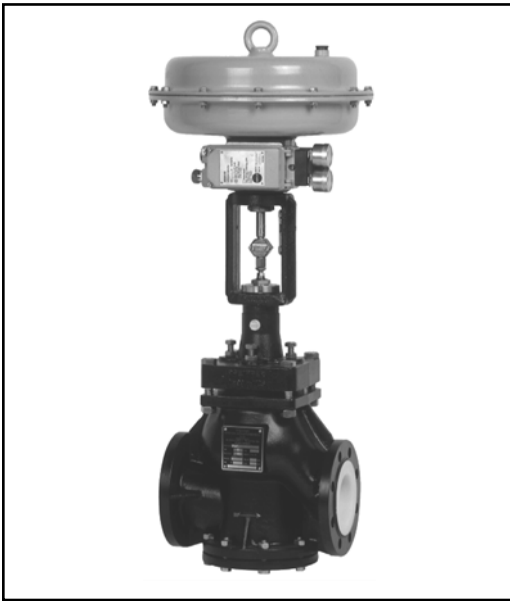

Fig. 1 – Series 1a Globe Valve with Samson Actuator

are subject to alteration without notice. The text and illustrations do **not necessarily** display the scope of supply or any ordering of spare parts. Drawings and graphics are not to scale. Customer related special designs, which are not in accordance with our standard range, are not shown. All documents are protected by German copyright laws. The transmission and/or duplication of documents, even excerpts, as well as the use and communication of their content are not permitted unless expressly granted. Offenders will be liable for payment of damages. All rights to exercise industrial property rights are reserved.

0. Contents

1. Introduction	1
2. Design, operation and dimensions	2
3. Installation, start-up and maintenance	2
4. Assembly of the control valve	2
4.1 Assembly of the valve in DIN version	2
4.2 Assembly of the valve in ANSI version	6
4.3 Stroke adjustment	10
5. Troubleshooting	11
6. Repair of the control valve	11
6.1 Replacing the bellows	11
6.2 Replacing the bellows and packing	11
6.3 Readjustment of the stuffing box (option)	11
6.4 Further repair work	12
7. Customer inquiries	12

1. Introduction

These instructions are intended to assist the user on assembly and repair of Series 1a Control Valves. Technical details, as a result of further development of valves mentioned in these instructions

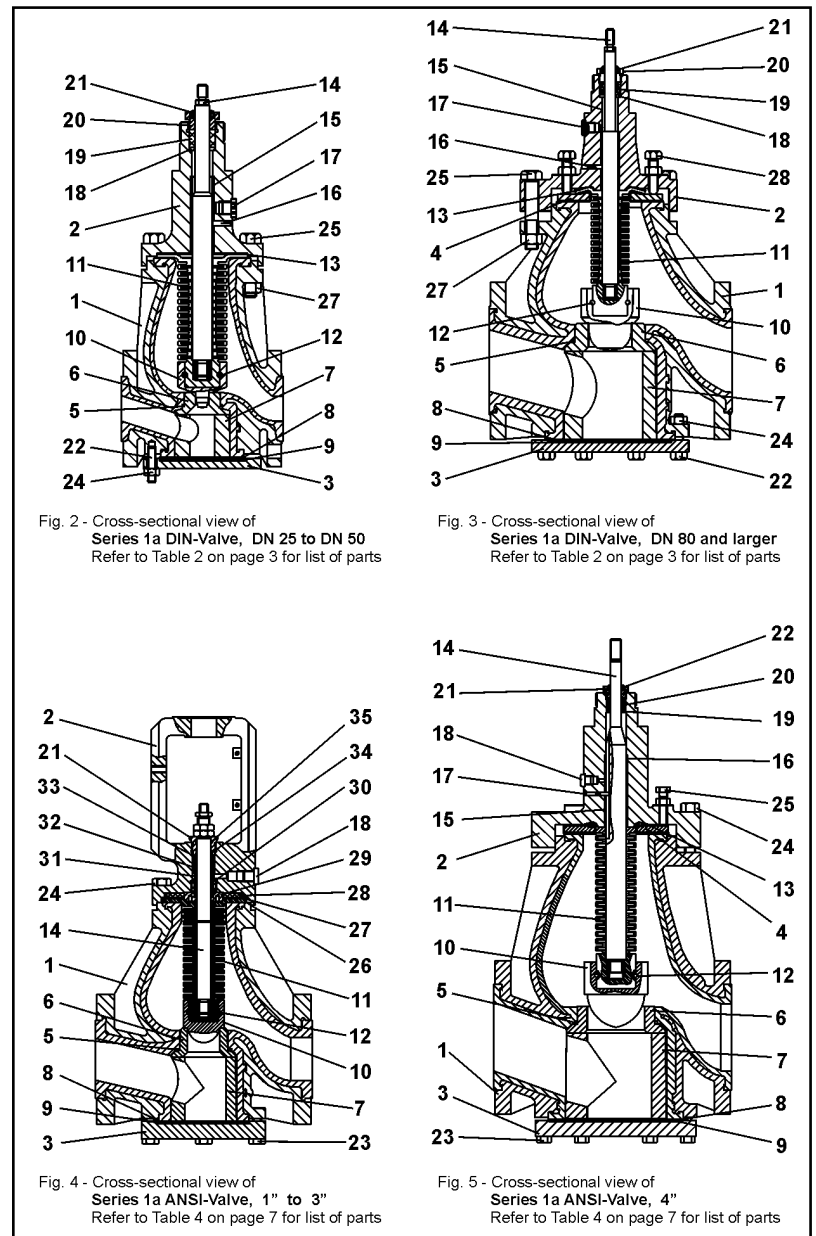

Fig. 2 - Cross-sectional view of Series 1a DIN-Valve, DN 25 to DN 50 Refer to Table 2 on page 3 for list of parts

Fig. 3 - Cross-sectional view of Series 1a DIN-Valve, DN 80 and larger Refer to Table 2 on page 3 for list of parts

Fig. 4 - Cross-sectional view of Series 1a ANSI-Valve, 1" to 3" Refer to Table 4 on page 7 for list of parts

Fig. 5 - Cross-sectional view of Series 1a ANSI-Valve, 4" Refer to Table 4 on page 7 for list of parts

Globe Control Valve Series 1a



The equipment may only be dismantled and disassembled by skilled staff who are familiar with the assembly, start-up, and operation of this product.

In these maintenance and assembly instructions, the term skilled staff refers to individuals who are able to judge the responsibilities assigned to them as well as recognize potential hazards due to their specialized training, knowledge, and experience as well as their special knowledge of the relevant standards.



Note! A high-performance grease paste is used during manufacturing to prevent the screws from cold welding in the bodies (e.g. Gleitmo 805 by Fuchs).

Do not use this lubricant with valves intended for oxygen service. Use a lubricant suitable for valves that are free of grease, especially for oxygen service.



Note! The position and arrangement of the individual parts shown in the detail drawing (Fig. 6) are to be observed during assembly.

2. Design, operation and dimensions

Design, operation, and dimensions as well as all further details and technical data can be found in **Data Sheet**

<TB 01a_EN> for control valves in **DIN version**

<TB 01a-an_EN> for control valves in **ANSI version**.

3. Installation, start-up and maintenance

Instructions for the installation, start-up and maintenance are to be found in **Operating Instructions**

< BA 01a-01_EN > for pneumatic valves,

< BA 01a-02_EN > for manually operated valves.

4. Assembly of the control valve

The **current DIN versions** of the Series 1a Control Valves have a different stem sealing design compared to the **current ANSI version**, meaning that they cannot be covered by the same instructions.

The **DIN valve** version is first described from **page 2** onwards. Refer to the **page 6** for the description of the **ANSI valve** version.

4.1 Assembly of the valve in DIN version

4.1.1 Preparation for assembly

Before assembling the valve, carefully clean all parts and place them on a soft surface (rubber mat or similar). Please note that plastic parts are nearly always soft and very sensitive. Take particular care when handling the sealing surfaces to ensure that they do not get damaged.

4.1.2 Preassembling the valve body

Place the valve body (1) with the bonnet flange facing downwards on a flat, clean working surface to allow easy working access to the bearings in the seat.

Clean the PTFE lining of the body with a cleaning agent. Place PTFE O-ring (5) into the groove of the valve body.



Note! Depending on the temperature, it may be necessary to shrink it slightly by either using a cooling spray or by placing it in the refrigerator.

Push the seat (6) into the body.
Press spacer (7) into the body and onto the seat (6).



Note! Make sure that the through hole in the spacer is aligned properly with inlet port of the valve. Similarly, the top of the spacer must lie flat with the facing of the body flange.

Drill a 5 mm hole approx. 10 mm deep into the spacer at an angle from the facing. Thread a piece of PTFE cord (12) into this drilled hole to secure the spacer against twisting.

Place the PTFE washer (8) on the spacer in the body. Then place the elastomer inlay (9) onto the PTFE washer. Carefully place the bottom flange (3) on the body, making sure the washer (8) and inlay (9) fit centrally.

Insert bolts (22) through the bonnet and use the nuts (24) to position them correctly. Tighten the bolts evenly in an alternating pattern.



Note! Observe the tightening torques in Table 1.

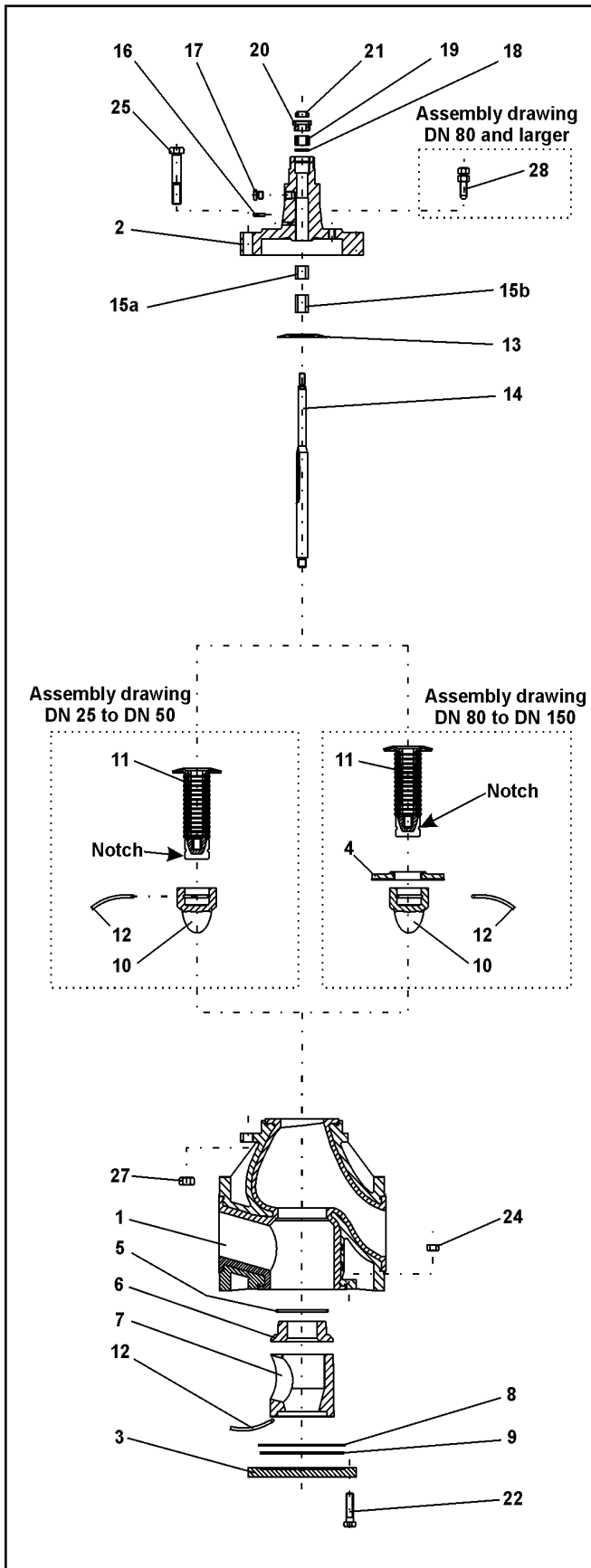

Fig. 6 - Detailed drawing of Series 1a Valve

Nominal size	DN 25	DN 40	DN 50	DN 80	DN 100	DN 150
Torques	10 Nm	15 Nm	25 Nm	30 Nm	30 Nm	40 Nm

Table 1 - Tightening torques

4.1.3 Preassembling the stem

Apply lubricant to the bottom of the thread of the one-piece stem (14).



Note! Some versions have a stem consisting of three parts with the guide ready-mounted to the stem with a snap ring.

Screw tight the bellows (11) ready-mounted with washer and Ensat bushing onto the greased thread of the stem (14).



Note! Due to the sliding property of PTFE, we recommend using emery cloth to prevent the bellows from slipping when screwing it onto the stem.

Item	Description	Material
1	Valve body	1049 / PTFE
2	Bonnet flange	1049
3	Bottom flange	1049
4	Bordered flange	St 37 / PTFE
5	O-ring	PTFE
6	Seat	PTFE
7	Spacer	PTFE
8	Washer	PTFE
9	Inlay	Uniseal 3400
10	Plug	PTFE
11	Bellows	PTFE
12	Cord	PTFE
13	Washer	Uniseal 3400
14	Stem	1.4571
15	Bushing	Glycodur F
16	Grooved pin	1.4301
17	Blanking plug	St, yellow zinc-plated
18	Washer	1.4571
19	Packing	PTFE-graphite
20	Stuffing box	1.4301
21	Wiper ring	Buna
22	Hex bolt	A2-70
24	Hex nut	A2-70
25	Hex bolt	A2-70
27	Hex nut	A2-70
28	Hex screw	A2-70

Table 2 - List of parts

Globe Control Valve Series 1a

4.1.3.1 Assembling the stem for DN 25 to DN 50

To neatly push the plug onto the stem, make a small notch in the bellows to let air escape.

Push the plug (10) onto the bellows (11). Secure the connection between plug and bellows with PTFE cord (12) inserted as far as it will go.

To complete the stem assembly, thoroughly grease the groove of the stem.

4.1.3.2 Assembling the stem for DN 80 to DN 150 / (6")

To reduce corrosion, apply grease to the metal side of the bordered flange (4). Push the bordered flange over the bellows as far as it will go.

To neatly push the plug onto the stem, make a small notch in the bellows to let air escape. Push the plug (10) onto the bellows (11).

Secure the connection between plug and bellows with PTFE cord (12) inserted as far as it will go.

To complete the stem assembly, thoroughly grease the groove of the stem.

4.1.4 Preassembling the bonnet flange

Prior to mounting, grease the inside of the bonnet flange (2). Thread in the screws (28) slightly so that they do not jut out inside of the bonnet.



Note! Control valves in nominal sizes DN 25 to DN 50 are mounted without the screws (28).

To continue mounting, clamp the bonnet flange with the stem guide facing downwards in a vise.

Insert the Glycodur bushings. If these have different lengths, insert the shorter bushing (15a) into the stem guide as far as it will go with Loctite using a suitable mandrel.

Push the longer bushing (15b) until it is flush with the inside surface of the bonnet, also with Loctite using a suitable mandrel.

Hammer in the grooved pin (16). Screw in the blanking plug (17). Insert the washer (13) into the groove of the bonnet flange intended for it. Place the ready-assembled stem into the bonnet.

4.1.5 Final assembly of the valve (stuffing box in standard version)

Carefully place the ready-mounted valve body on the bonnet flange.



Note! The pneumatic connection (17) in the bonnet flange and the nameplate on the valve body (1) must face in the same direction.

Insert the screws (25), align and position them using the nuts (27). Tighten the screws evenly in an alternating pattern.



Note! Tightening the screws causes the position of the plug to change. Therefore, make sure that the plug remains centric. When tightening the screws, move the stem (14) to check that it can still move easily. If the stem gets jammed, the plug, seat and guide could be damaged as a result.

Mount the stuffing box by first positioning the washer (18) and then insert the packing rings (19) into the bonnet using a special mandrel.



Note! Make sure that the packing rings are inserted offset to ensure the divisions of packing rings do not become aligned.

Press the wiper ring (21) into the gland nut (20).

Screw the ready-assembled stuffing box (20) into the bonnet. After tightening it manually, unscrew it by half a turn and retighten it again.



Note! Make sure that the packing is pressed neatly and does not bulge through the stuffing box.

4.1.6 Final assembly of the valve (version with optional adjustable backup stuffing box)

For the final assembly of the valve, proceed as described in section 4.1.5.

However, do not unscrew the stuffing box (20) and retighten it. Instead, unscrew it completely and remove it from the valve.



Note!

Clean the removed stuffing box to ensure it is free of grease.

Apply Loctite 668 to the thread of the stuffing box (20).
Screw the stuffing box back into the bonnet flange.



Caution! Do not screw tight the stuffing box. The distance between the collar of the stuffing box and the bonnet must be 3 mm!

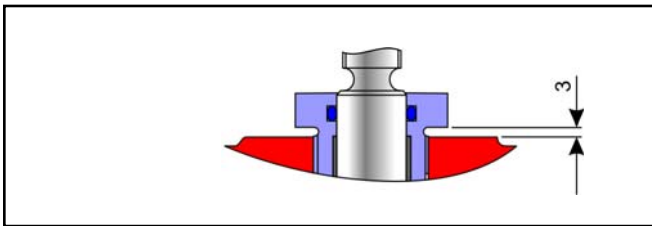

Fig. 7 - Adjustable packing

Seal the stuffing box with a dot of red point.

4.1.7 Assembly of the valve is now complete

When the valve and Samson actuator are delivered separately, the stroke needs to be adjusted. Refer to section 4.3 for details.

Globe Control Valve Series 1a

4.2 Assembly of the valve in ANSI version

4.2.1 Preparation for assembly

Before assembling the valve, carefully clean all parts and place them on a soft surface (rubber mat or similar).

Take into consideration, that parts made of plastic are generally soft and sensitive. In particular, the sealing surfaces must be handled with care to ensure that they are not damaged.



Note! To avoid cold corrosion of the screws in the bodies, the manufacturer has used a high-performance lubricating grease (e.g. Gleitmo 805 from Fuchs).

Do not use this lubricant with valves intended for oxygen service. Use a lubricant suitable for valves that are free of grease, especially for oxygen service.



Note! The position and arrangement of the individual parts shown in the detail drawing (Fig. 8) are to be observed during assembly.

4.2.2 Preassembling the valve body

Place the valve body (1) with the bonnet flange facing downwards on a flat, clean working surface to allow you to easily access the bearings in the seat.

Clean the PTFE lining of the body with a cleaning agent. Place the PTFE O-ring (5) into the groove of the valve body.



Note! Depending on the temperature, it may be necessary to shrink it slightly by either using a cooling spray or by placing it in the refrigerator.

Push the seat (6) into the body.
Press spacer (7) into the body and onto the seat (6).



Note! Make sure that the through hole in the spacer is aligned properly with inlet port of the valve. Similarly, the top of the spacer must lie flat with the facing of the body flange.

Drill a 5 mm hole approx. 10 mm deep into the spacer at an angle from the facing.
Thread a piece of PTFE cord (12) into this drilled hole to secure the spacer against twisting.

Place the PTFE washer (8) on the spacer in the body. Place the elastomer inlay (9) onto the PTFE washer.

Carefully place the bottom flange (3) on the body, making sure the washer (8) and inlay (9) fit centrally.

Insert bolts (23) through the bonnet and, depending on the type, use the nuts (37) to position them correctly, or screw them directly into the valve body.

Tighten the bolts evenly in an alternating pattern.



Note! Observe the tightening torques in Table 3.

Nominal size	1"	1 1/2"	2"	3"	4"	6"
Torques	10 Nm	15 Nm	25 Nm	30 Nm	30 Nm	40 Nm

Table 3 - Torques for bottom flange

4.2.3 Preassembling the stem

Apply lubricant to the bottom of the thread of the one-pieced stem (14).



Note! Some versions have a stem consisting of three parts with the guide ready-mounted to the stem with a snap ring.

Screw tight the bellows (11) ready-mounted with washer and Ensat bushing onto the greased thread of the stem (14).



Note! Due to the sliding property of PTFE, we recommend using emery cloth to prevent the bellows from slipping when screwing it onto the stem.

4.2.3.1 Assembling the stem for 1" to 3"

To neatly push the plug onto the stem, make a small notch in the bellows to let air escape.

Push the plug (10) onto the bellows (11).
Secure the connection between plug and bellows with PTFE cord (12) inserted as far as it will go.

To complete the stem assembly, thoroughly grease the groove of the stem.

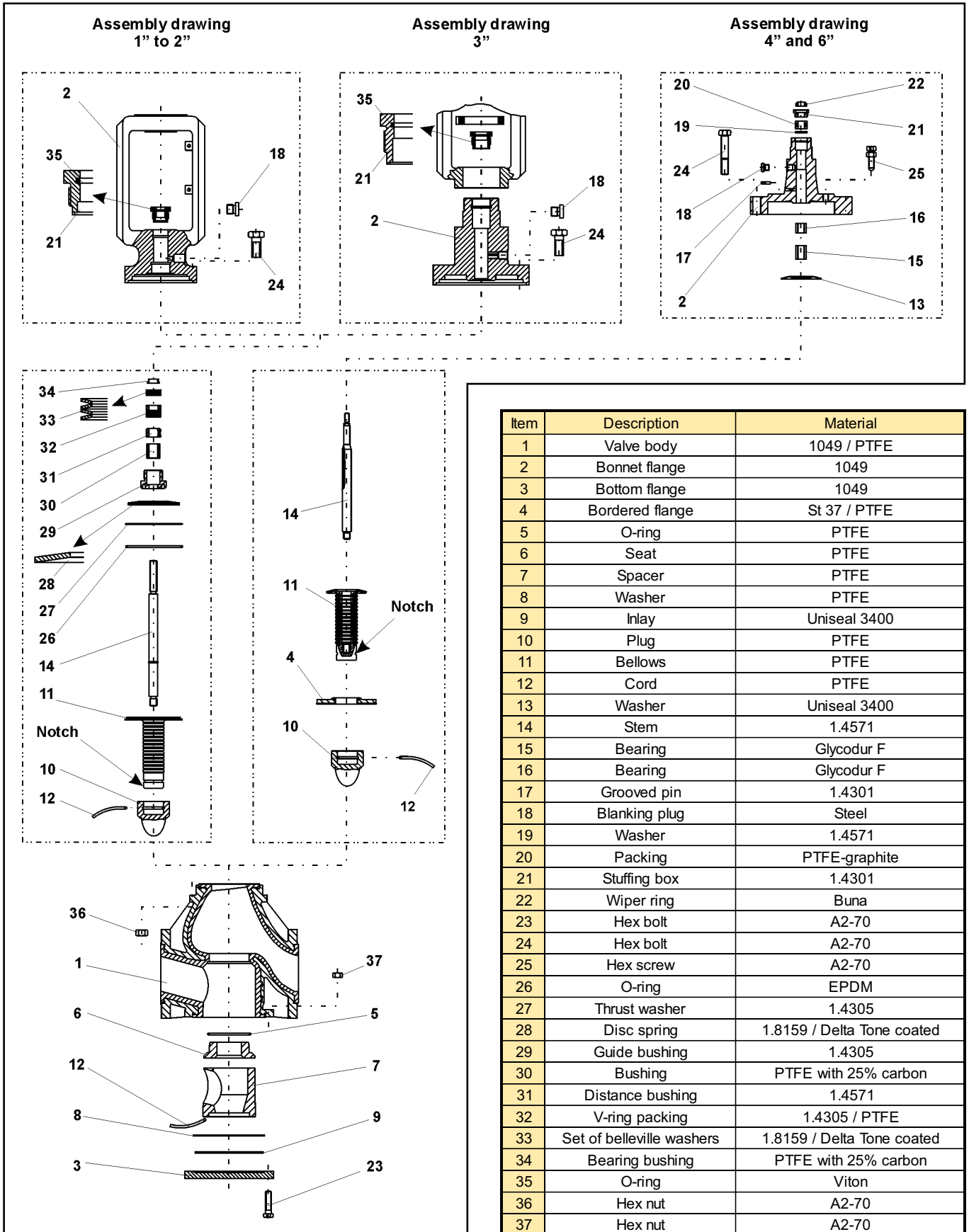

Fig. 8 - Detailed drawing of series 1a valve

Table 4 - List of parts

Globe Control Valve Series 1a

4.2.3.2 Assembling the stem for 4" and 6"

Apply grease to the metal side of the bordered flange (4) to reduce corrosion. Push the bordered flange over the bellows as far as it will go.

To neatly push the plug onto the stem, make a small notch in the bellows to let air escape.

Push the plug (10) onto the bellows (11).

Secure the connection between plug and bellows with PTFE cord (12) inserted as far as it will go.

To complete the stem assembly, thoroughly grease the groove of the stem.

4.2.4 Preassembling the bonnet flange

4.2.4.1 Assembly of bonnet flanges 1" to 2"

Place the O-ring (35) in the inside groove of the stuffing box (21).

Press the top bearing bushing (34) into the bottom part of the stuffing box (21).

Screw the greased thread of the stuffing box (21) into the top thread of the bonnet flange (2), ensuring that the external groove is still visible.



Note!

Do not screw the stuffing box (21) as far as it will go into the bonnet flange.

Clamp the bonnet flange (2) at the yoke in a vise with the flange opening facing upwards.

Place the set of Belleville washers (33) into the borehole intended for it. Refer to the exploded view diagram (Fig. 8) for the arrangement.

Insert the final ring, PTFE V-rings (32) and distance bushing (31) one after the other.

Press the bottom bearing bushing (30) into the bore of the guide bushing (29).

Screw the guide bushing (29) lubricated at the thread into the bonnet flange (2) as far as it will go.



Note!

Make sure that the guide bushing does not get jammed on screwing it into the bonnet flange.

Insert the disc spring (28), thrust washer (27) and O-ring (26) in the bonnet flange (2). Refer to the exploded view diagram (Fig. 8) for the arrangement.

Place the ready-assembled stem (refer to section 4.2.3.1) into the bonnet and press the flange of the bellows into the groove of the bonnet flange.

To complete the bonnet flange assembly, screw in the blanking plug (18).

4.2.4.2 Assembly of bonnet flange 3"

Assembly of the bonnet flange for 3" is identical to the assembly described in section 4.2.4.1 for the bonnet flange 1" to 2".

The difference is that the bonnet flange described does not have an integrated yoke. As a result, to assemble the bonnet flange (2), clamp the shaft of the stem guide in a vise.



Note! Make sure that the bonnet flange and particularly the thread at the end of the shaft do not get damaged.

After completing the bonnet flange assembly, push the yoke onto the bonnet flange and fasten it with the slotted round nut.

4.2.4.3 Assembly of bonnet flanges 4" and 6"

Prior to mounting, grease the inside of the bonnet flange (2).

Thread in the screws (25) slightly, ensuring they do not jut out inside of the bonnet.

To continue assembly, clamp the bonnet flange with the stem guide facing downwards in a vise.



Note! Make sure that the bonnet flange and particularly the thread at the end of the shaft do not get damaged.

Insert the Glycodur bushings.

If these have different lengths, insert the shorter bushing (16) into the stem guide as far as it will go with Loctite using a suitable mandrel.

Push the longer bushing (15) until it is flush with the inside surface of the bonnet, also with Loctite using a suitable mandrel.

Hammer in the grooved pin (17).Screw in the blanking plug (18).

Insert the washer (13) into the groove of the bonnet flange intended for it.

Place the ready-assembled stem into the bonnet.

4.2.5 Final assembly of the valve (stuffing box in standard version)

4.2.5.1 Final assembly of valve 1" to 3"

Clamp the ready-assembled valve body (section 4.2.2) with the bonnet opening facing upwards in a vise.

Carefully place the bonnet flange assembled in section 4.2.4.1 or 4.2.4.2 onto the body.



Note! The pneumatic connection (18) in the bonnet flange and the nameplate on the valve body (1) must face in the same direction.

Insert the bolts (24) through the bonnet flange (2). Depending on the type, use the nuts (36) to position them or directly screw them into the valve body.



Note! To prevent the plug from becoming jammed, pull the plug upwards as far it will go before tightening the bolts.

Fasten bolts evenly in an alternating pattern.
After adjusting the valve, screw tight the stuffing box (21).

Screw the lock nuts on the stem. Position the nuts as described in section 4.3.

4.2.5.2 Final assembly of valve 4" and 6"

Carefully place the ready-assembled valve body (section 4.2.2) onto the pre-assembled (section 4.2.4.3) bonnet flange.



Note! The pneumatic connection (18) in the bonnet flange and the nameplate on the valve body (1) must be facing in the same direction.

Insert the bolts (24) through the bonnet flange (2).

Depending on the type, use the nuts (36) to position them or directly screw them into the valve body.

Fasten bolts evenly in an alternating pattern.



Note! Tightening the bolts causes the position of the plug to change. Therefore, make sure that the plug remains centric. Move the stem (14) while tightening the bolts to test whether it can still move easily. If the stem gets jammed, the plug, seat and guide could be damaged as a result.

Mount the stuffing box by first positioning the washer (19) and then insert the packing rings (20) with a special mandrel into the bonnet.



Note! Make sure that the packing rings are inserted offset to ensure that the divisions of packing rings do not become aligned.

Press the wiper ring (22) into the gland nut (21).

Screw the ready-assembled stuffing box (21) into the bonnet.

After tightening it manually, unscrew it by half a turn and retighten it again.



Note! Make sure that the packing is pressed neatly and does not bulge through the stuffing box.

4.2.6 Final assembly of the valve (version with optional adjustable backup stuffing box)

For the final assembly of the valve, proceed as described in section 4.2.5.

However, do not unscrew the stuffing box (20) and retighten it. Instead, unscrew it completely and remove it from the valve.



Note! Clean the removed stuffing box to ensure it is free of grease.

Apply Loctite 668 to the thread of the stuffing box (20).
Screw the stuffing box back into the bonnet flange.

Globe Control Valve Series 1a



Caution! Do not screw tight the stuffing box. The distance between the collar of the stuffing box and the bonnet must be 3 mm!

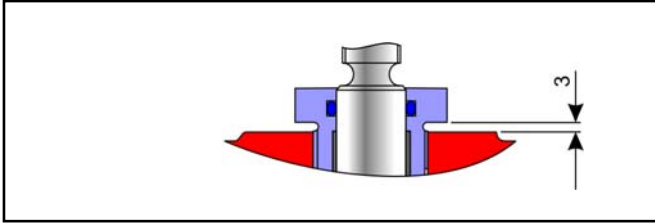

Fig. 9 – Adjustable stuffing box

Seal the stuffing box with a dot of red point.

4.2.7 Assembly of the valve is now complete

If the valve and Samson actuator are delivered separately, the stroke needs to be adjusted. Refer to section 4.3 for details.

4.3 Stroke adjustment

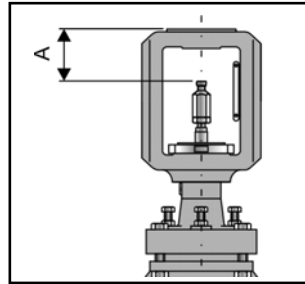

Fig. 10 - Stroke adjustment

If the valve and Samson actuator are delivered separately, set the dimension A from the top of the stem connector nut to the top of the yoke as specified in Table 5. Check the dimension when assembling the valve and actuator together.

Stroke adjustment with Samson actuators (valve closed)	
DN	A
25 to 80 and 1" to 3"	75 ± 0.1
100 to 150 and 4" to 6"	90 ± 0.1

Table 5 – Stroke adjustment

4.3.1 Stroke limited to 10 mm with fail-safe action “Actuator stem retracts – STEF”

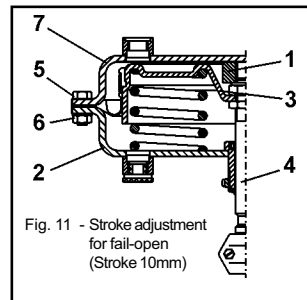

Fig. 11 - Stroke adjustment for fail-open (Stroke 10mm)

The stroke for fail-safe action “Actuator stem retracts” can be limited using a spacer (1) with a female thread. It is screwed and cemented onto the actuator stem (4) and situated between diaphragm case (7) and diaphragm plate (3). This keeps the springs under tension during the assembly.

- To limit the stroke, loosen the bolts (5) and nuts (6) and remove the top diaphragm case (7).
- Screw the spacer (1) onto the actuator stem (4) and cement with Loctite.
- Fasten the top diaphragm case (7) by tightening the bolts (5) and nuts (6) evenly in an alternating pattern.

4.3.2 Stroke limited to 15 or 30 mm with fail-safe action “Actuator stem retracts – STEF”

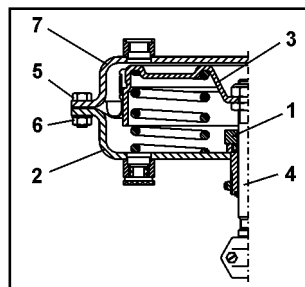

Fig. 12 - Stroke adjustment for fail-open (15/30mm)

The stroke for fail-safe action “Actuator stem retracts” can be limited using a spacer (1), which is pushed onto the actuator stem (4) and situated between the bottom diaphragm case (7) and diaphragm plate (3).

This spacer is manufactured to size during the assembly of the valve and actuator.

The dimensions listed in Table 6 provide sufficient pretensioning of the actuator to achieve tight shut-off between the seat and plug.

Stroke 15 mm	Actual stroke 16 to 17 mm
Stroke 30 mm	Actual stroke 31 to 32 mm

Table 6 – Actual stroke

- To limit the stroke, unscrew nuts (6) and bolts (5) and lift off the top diaphragm case (7).
- Carefully take the diaphragm plate (3) together with the actuator stem (4) out of the actuator.
- Slide the spacer (1) over the actuator stem (4).
- Place the diaphragm plate (3), actuator stem (4) with spacer (1) back in the actuator.
- Put back on the top diaphragm case (7) and tighten (6) and bolts (5) evenly and in an alternating pattern.

4.3.3 Stroke limited to 10 mm with fail-safe action “Actuator stem extends – STAF”

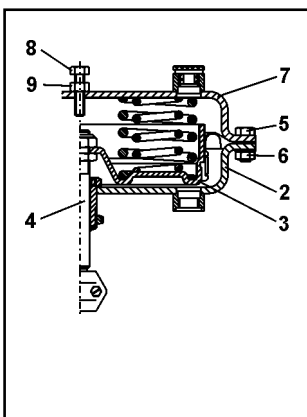

Fig. 13 - Stroke adjustment for fail-close

The use of spacer screw (8) is used to limit the stroke for the fail-safe action “Actuator stem extends” with Kvs 0.005, 0.01, 0.05 and a seat bore of 2 mm. The maximum stroke of 10 mm must not be exceeded. Otherwise, the plug is not guided in the seat anymore when the valve opens and would be damaged or break off when the valve closes again, as guidance in the seat cannot be ensured.

- To limit the stroke, drill a hole in the top diaphragm case (7) with a corresponding thread for an M10x1 screw.
- After mounting the actuator on the valve, screw the M10x1 screw (8) into position with the lock nut (9).
- The screw (8) is used for exact adjustment of the limit stroke. After adjustment, lock the position with the lock nut (9).

5. Troubleshooting

Refer to section 7 of **Operating Instructions**

< BA 01a-01_EN > for pneumatic valves or
< BA 01a-02_EN > for manually operated valves.

6. Repair of the control valve

6.1 Replacing the bellows

If a leak is detected at the leak-off connection (18/17), the bellows (11) may be defective. We recommend checking the condition of the bellows.

To remove the bellows, disassemble the valve in reverse order to the assembly instructions in section 3. Check the bellows and all plastic parts for damage. In case of doubt, replace the parts with new ones.

6.2 Replacing the bellows and packing

If the valve leaks at the packing, the packing and the bellows may be defective. We recommend checking the condition of all the seals and the bellows.

To remove the packing and the bellows, disassemble the valve in reverse order to that described in section 3. Check the packing and bellows including all plastic parts for damage. In case of doubt, replace the parts with new ones

6.3 Readjustment of the stuffing box (option)

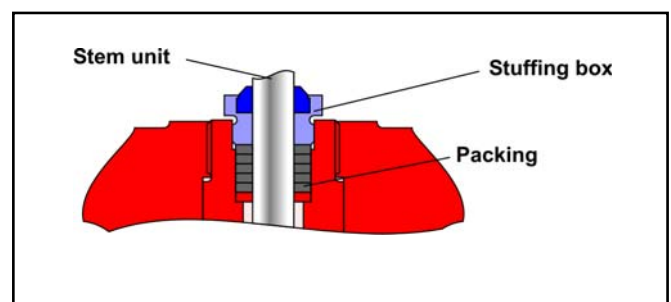

Fig. 14 – Version with adjustable backup stuffing box

This version does not have a leak-off connection on the bonnet.

The backup stuffing box:

- Not gas tight from around 2 bar in the delivered state
- Stuck in position with Loctite 668
- Seal with red paint as a marking.
Adjustment YES/NO
- Can be tightened approximately 3 mm further, making it gas tight up to 16 bar.

The glued connection:

- Constantly stuck, but the stuffing box can still be tightened with a tool
- Designed for a temperature range between
-10 to +200 °C

If the valve leaks at the stuffing box, the bellows is defective.



Caution! All necessary safety measures must be taken to avoid any possible accidents. Always take into account that you are nearly always dealing with dangerous medium.

Tighten the stuffing box.



Caution! The valve no longer leaks, however, it should be repaired as quickly as possible, as there is no primary sealing. The sealing through the stuffing box should only be for a short period.

The repair work is described in section 6.1.

6.4 Further repair work

In case of severe damage, we recommend the repair work to be carried out by Pfeiffer.

7. Customer inquiries

(Should you have any inquiries, please submit the following details:)

1. Order number (embossed on the nameplate)
2. Type, product number, nominal size, and version of the valve
3. Pressure and temperature of the process medium
4. Flow rate in m³/h
5. Installation drawing, if possible

For your special requirements please contact our technical sales department.

Pfeiffer Chemie-Armaturenbau GmbH

Hooghe Weg 41 • 47906 Kempen

Phone: +49 21 52 20 05 - 0 • Fax: +49 21 52 15 80

E-mail: vertrieb@pfeiffer-armaturen.com • Internet: www.pfeiffer-armaturen.com

Specifications subject to change without notice.