

Maintenance and repair instructions

Shut-off valve Series 17z



Fig 1 - Shut-off valve Series 17z

0. General:

These instructions are intended to assist the user in the assembly and operation of the shut-off valve series 17z. It is therefore important to follow these instructions.



This equipment may only be dismantled and disassembled by skilled personal, who are familiar with the assembly, start-up and operation of this product. All personal should be equipped with necessary tools and appropriate protective clothing. If the valve is not intended for immediate use, store in the original packing with the disc slightly open.

The valves are designed to customer specifications for a specific function. For this reason, they should only be used for that purpose. In compliance to these requirements, the valve, if applicable is then identified according to 97/23/EG.



Note: Important construction parts of the valve should be checked in regular intervals regarding their application function.

1. Design, operation and dimensions:

The design, operation, dimensions and all further technical details can be found in **Data sheet < TB 17z-wz_EN >**.

2. Assembly in the pipeline and operation of the valve:

2.1 Flange connection

The dimensions of these shut-off valves are so designed, that they can be fitted to all known DIN- and ANSI- flanges.

If the valve is used as an end valve instead of being fitted between pipings, ensure that there is no danger when draining. Dimensions for flanges and flange connections screws must be according to the operating instructions. Ensure, that control valves, which are designed for a certain flange norm, do not fit other flanges (other ND-bore holes).

Ensure also, that the flanges are parallel to each other, the surfaces have been carefully mached and are not damaged and stressed relieved when connecting. For the layout of the flanges see fig. 3 at the end of these instructions.



Note: The use of flange sealings on flanges with flange rubber is not permissible. Flange sealings should only be applied to metal sealing valves.

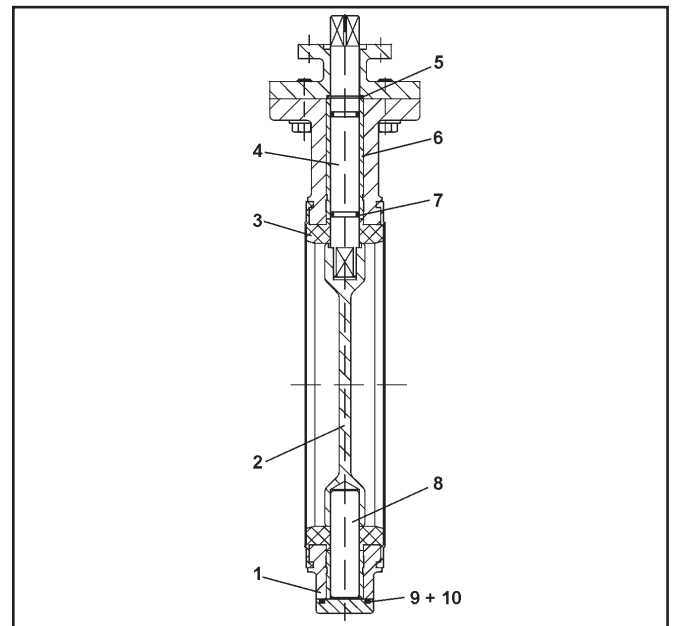

Fig. 2 - Sectional view of a disc, Series 17z -type WZ

Pos.	Description	Pos.	Description
1	Valve body	6	Guiding sleeve
2	Valve disc	7	O-Ring
3	Sealing gasket	8	Bearing pin
4	Valve shaft	9	O-Ring
5	Retaining ring	10	End-plate

Table 1 - Parts list

Shut-off valve Series 17z

2.2 Installation

Before installing, check the valve for functional efficiency. Especially the sealing lips to the flange sealing should be in a faultless condition.

Check the gearing i.e. the drive on the valve for easy movement, on no account use force!!

Furthermore, check if the valve corresponds to the required specifications.

The sleeve, valve disc and the shaft must show sufficient consistency and durability to the flow media.

The pressure and temperature levels stated on the valve must be above the operating specifications. Central shut-off valves are suitable for through flow in both directions. This has no effect on the sealing tightness or on the flow through characteristics.

Prior to installing, force the piping apart with an appropriate tool - on no account should the valve be misused for this purpose.

In the case of a vertical installation, especially by large nominal diameters, install the shaft with the shaft in a horizontal position.

By closing the bottom half of the valve disc in flow direction, a self-cleaning effect is achieved.

After the valve is vertically installed and the correctly aligned in the piping first insert the screws in the bottom half of the flange.

If the flanges do not have flange rubber, apply graphite or similar to both flange sealings by pushing between the flanges.

Position the valve and the flange sealings in a central position to the pipe cross-section and tighten lightly the bottom flange connecting screws.

Insert the remaining connecting screws and tighten in alternating pattern to avoid the body twisting or distorting.



Note: Avoid any welding work near the flange when the valve is installed. The heat caused through the welding process will inevitably lead to the sealing being damaged.

When working outside, make sure that, electrical components are not directly exposed to weather conditions – if necessary install a folding plate.



Important: After installing, check the valve for functional operation.

2.3 Actuator

Depending on the valve design, the valve can be operated by hand-lever, hand gear, pneumatic actuator, or an electrical actuator.

After disassembly/reassembly of the actuator, check the actuator setting adjustments.

Pneumatic operated shut-off valves should be "slightly pre-set" to allow an easy opening, i.e. in order to maintain a sealing reserve in case of wear.



In general, the following applies for valves:
turn to the right = valve closes
turn to the left = valve opens.

Depending on the flow media (especially by fluids) the shut-off valves open and close slowly, in order to avoid shocks in the piping system.

3. Technical operation :

The shut-off valves are designed as intermediate valves with central, also eccentric bearing valve disc.

The body is cast in a single piece, only the stainless steel bodies are made in a welding construction. The lining of the body and the flange rubber are designed in one piece, and can be fixed i.e. galvanised or detachable. The dimensions of the flange rubber are such, that a complete sealing in the through flow and at the flange connection is assured without an additional flange sealing, enabling the valve to function completely efficiently.

4. Maintenance and repair:

Apart from the regular inspections to be carried out, it is not necessary to perform an additional service, e.g. lubricating the valve.

With regards to the inspection of the actuator, the manufacturer's maintenance instructions must be observed.

4.1 Stuffing box

Valves used for hot gases (temperature over 200°C) use the stuffing box instead of O-rings for sealing the shaft. Leakage at the stuffing box packing can usually be eliminated by adjusting the stuffing box screw.

If this is not possible any more, the stuffing box packing must be replaced.



Note:
Avoid adjusting too firmly.

4.2 Parts subject to wear

The main part subject to wear in the shut-off valve is the V-ring packing. Depending on the particular application, a regular check for wear must be carried out, (necessary if used as end-pipe). By loosening the sealing elements, the replacement can be carried out by the customer in the factory without any problems. The replacement of hard vulcanised sealing gaskets is only possible at the manufacturer's works.

Complete sealing- and part-sets for abrasion are available for pneumatic actuators.



Important:
Only use original spare parts when assembling.

5. Dismantling the valve from the piping:

Before dismantling, approval must first be obtained from the authorised factory management (depending on the local regulations).



Important: If there is a pressure discharge in the piping, i.e. by dangerous media, this must be drained off and cleaned with an appropriate substance.



Important: For safety reasons, the power and air supply must first be shut off by an authorised and qualified person before assembly, disassembly, or any maintenance work on the valve can be carried out.

It is only possible to remove the valve from the piping system when the disc is closed.

6. Safety instructions and dangers:

Before working on the shut-off valve, the pressure in the pipeline must be switched off.



Attention: Never reach in a open valve disc with the hand, or any other part of the body, if the electric- and compressed air have not been switched off. Caution must be observed, especially by cleaning work.



Attention: If the valve is used with products with temperatures above +50°C this can lead to the valve body becoming intensely warm. Therefore, preventive measures must be taken to avoid skin burning by contact. Especially with manually operated valves, operating personal must wear adequate protective clothing i.e. protective gloves.



Attention: If there is a danger of explosion through an electrostatic charge, the valve must be earthed. If required, the shut-off valve can also be delivered as a special design with the valve disc directly earthed. In addition to this, electrical conductive sealings are also available (specific resistance less than 10⁴ Ohm) – however, only in black quality. The wiring of electrical parts can be taken from the relevant electrical installation data, and should only be installed by authorised qualified personal.

7. Dimensions of the connecting flange:

Fig A shows the **wrong** form for connecting the flange. The sealing sleeve bears the main force of the screws.

Fig B shows the **correct** form for connecting the flange. The sealing area of the connecting flange bears the main force of the screws.

8. Customer inquiries

(should you have any inquiries, please state the following:)

1. Commission number (embossed on the valve body)
2. Type, Product number, nominal diameter and valve version
3. Pressure and temperature of the process media
4. Flow rate in m³/h
5. Installation drawing, if possible

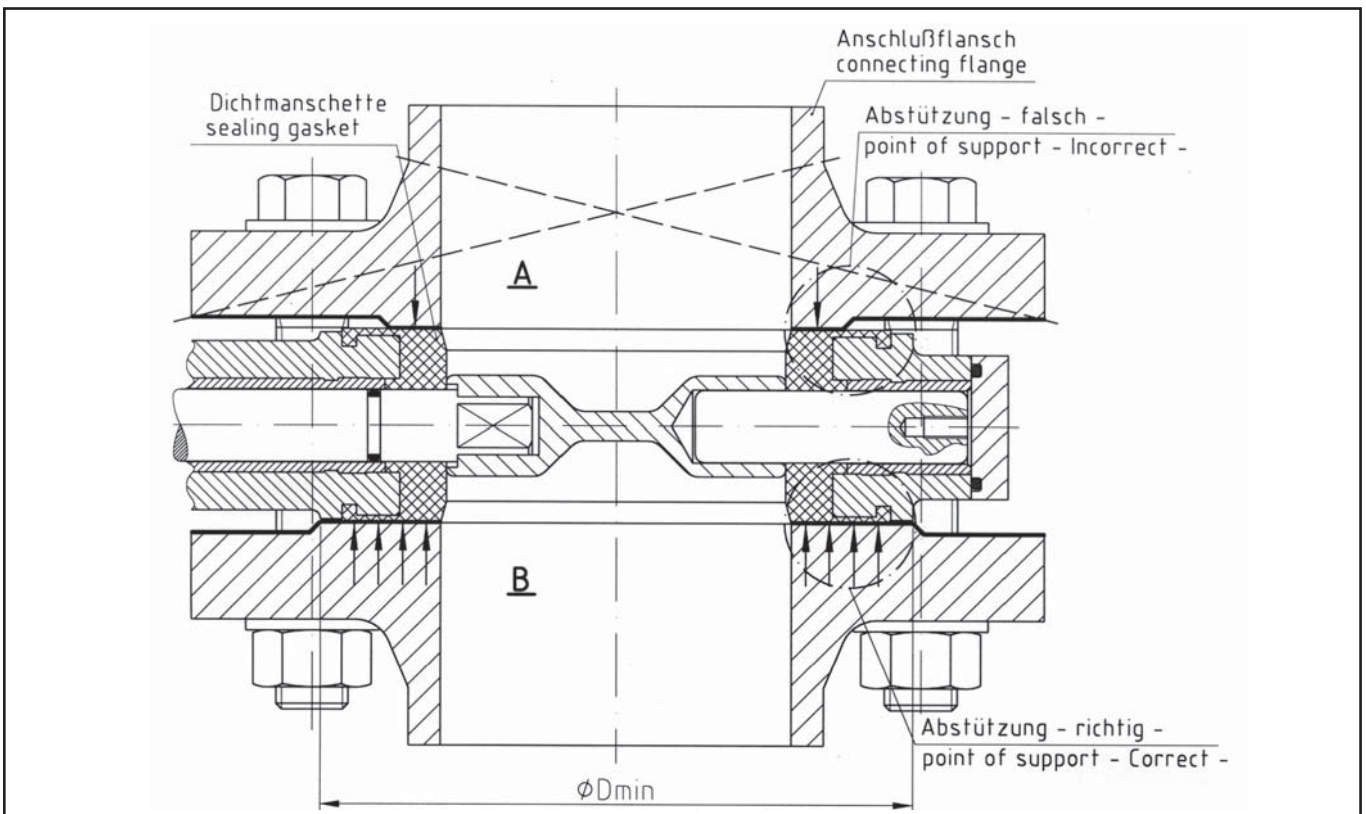

Fig 3 - Flange connections

DN	50	65	80	100	125	150	200	250	300	350	400	500	600	700	800	900	1000
ØDmin.	102	122	138	158	188	212	268	320	370	430	482	585	685	800	905	1005	1110

Table 2 - Connecting dimensions

Please contact our technical sales department for your
special requirements.

Pfeiffer Chemie-Armaturenbau GmbH

Hooghe Weg 41 • 47906 Kempen
Telefon: 02152 / 2005-0 • Telefax: 02152 / 1580
E-Mail: vertrieb@pfeiffer-armaturen.com • Internet: www.pfeiffer-armaturen.com

Specifications and versions are subject to change without notice