

# Operating, assembly and maintenance instructions for discontinuous sampling valve BR 27d



Fig. 1 - Sampling valve Series 27d

## 0. Introduction

These instructions are intended to support the user in the assembly and repair of sampling valves of the Series 27d.

Technical details, as a result of the further development of the valves mentioned in these instructions, are subject to alteration. The text and illustrations do not necessarily display the scope of supply or an eventual order of spare parts. Drawings and graphics are not to scale. Customer-related special designs, which are not in accordance with our standard offer, are not shown.

The transfer of these instructions to third parties is only allowed with the written approval of Pfeiffer Chemie-Armaturenbau GmbH. All documents are protected according to the laws of the German Copyright Act.

The transmission and/or duplication of documents, even in abstracts, as well as the exploitation and communication of their content is not permitted, unless expressly granted.

Violations are an offence and liable to claims for damages. We reserve all rights for the exercise of industrial property rights.



The equipment may only be dismantled and disassembled by skilled staff who are familiar with the assembly, the start-up and the operation of this product.

Skilled staff in the sense of these repair and assembly instructions are persons who, as a result of their training, their knowledge and their experience, as well as their knowledge of the relevant standards, are able to judge the tasks assigned to them and are able to recognize possible dangers.

## 1. Design, operation and dimensions

Design, operation and dimensions as well as all further details and technical data may be found in the **data sheet** < TB 27d\_EN >.

## 2. Installation, start-up and maintenance

Guidelines for the installation, start-up and maintenance are to be found in the **operating instructions** < BA 27d-01\_EN > for pneumatic sampling valves, resp. < BA 27d-02\_EN > for hand-operated sampling valves.

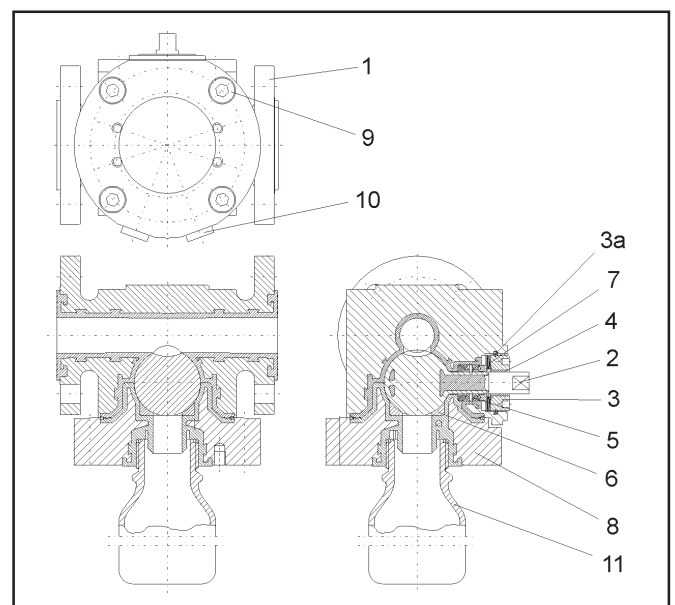

Fig. 2 - Sectional view of Series 27d Sampling valve => for parts list see table 1 on page 2

# Sampling Valve Series 27d

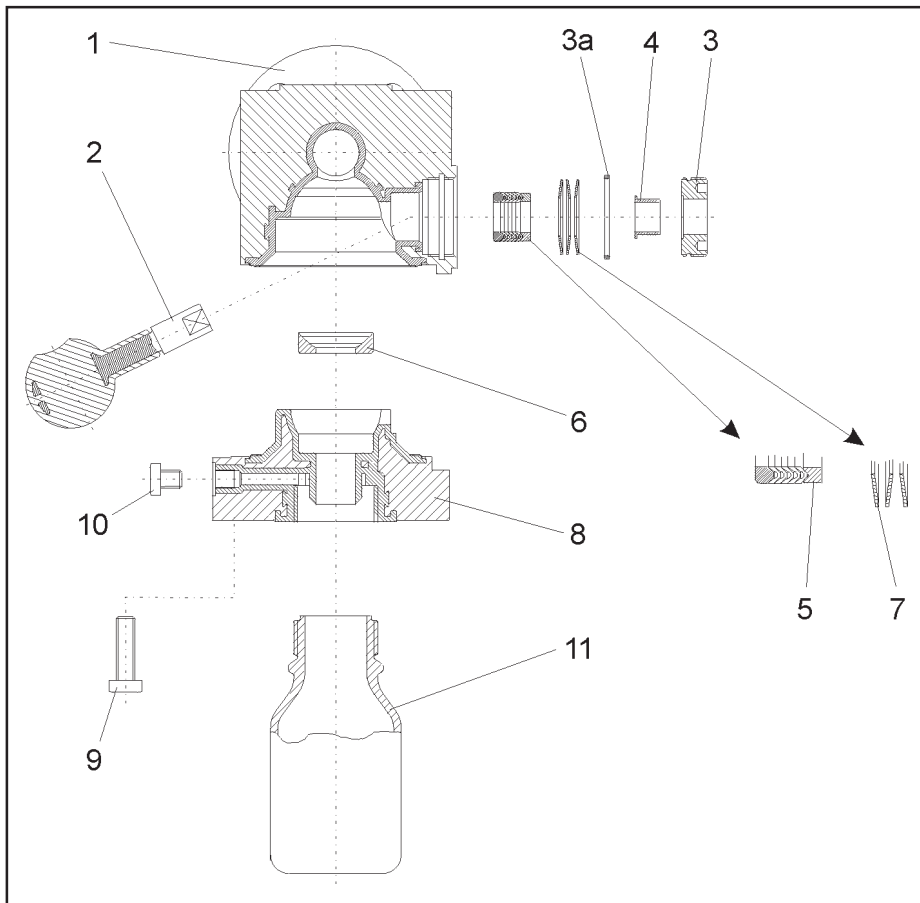

Fig. 3 – Exploded view of BR 27d Sampling Valve

Item	Qty.	Description	Material
1	1	Valve body	C22.8 / PFA
2	1	Ball	WN 1.4021 / PTFE
3	1	Stuffing box	WN 1.4305 / Peek
3a	1	Retaining ring	Peek
4	1	Bearing bushing	PTFE with 25% Carbon
5	1	V-ring packing	WN 1.4305 / PTFE
6	1	Sealing ring	PTFE
7	3	Spring washer	WN 1.8159 - Delta Tone
8	1	Bonnet	St 52-3 / PFA
9	4	Screw	A2-70
10	2	Locking screw	PTFE
11	1	Sample bottle	Glass

Table 1 - Parts list

## 3. Assembling the sampling valve

### 3.1 Preparation for assembly

To assemble the sampling valve, thoroughly clean all parts and lay them on soft padding (rubber mat, etc.). Take into account that parts made of plastic are nearly always soft

and very sensitive and that especially the sealing surfaces must not be damaged.



**Note:** The position and arrangement of the individual parts shown in the exploded view diagram must be strictly adhered to on assembling the valve.

### 3.2 Initial assembly of bonnet for the support

Insert the sealing ring ( 6 ) into the bonnet ( 8 ). Apply silicone grease (e.g. Wacker Silicone Grease 400 Medium or equivalent) to the sealing area of the ball.

### 3.3 Initial assembly of packing gland

Insert the bearing bushing ( 4 ) into the packing gland ( 3 ).

### 3.4 Assembling the ball valve body

Place the body ( 1 ) with sealing area of the ball facing upwards on a soft surface.

Apply silicone grease to the sealing area.

Insert the ball ( 2 ) into the body.

Apply grease (e.g. Gleitmo 805 from Fuchs or equivalent) to the cheese-head screws ( 9 ).

Place the ready-assembled bonnet on the body and align over the cheese-head screws. Tighten the screws evenly in an alternating pattern.

Turn the body in such a way that the shaft of the ball points upwards and the opening to mount the packing is easily accessible.

Apply silicone grease to all the V-rings of the packing ( 5 ). Insert the bottom V-ring first into the body bore using a blunt piece of piping.

Following this, insert each V-ring separately finishing with the stainless steel packing follower. Refer to the exploded view diagram (Fig. 3) for the exact arrangement of the packing.

Separate the Peek ring ( 3a ) on one side and insert it into the groove intended for it in the body.

Insert the set of Belleville spring washers ( 7 ). Refer to the exploded view diagram (Fig. 3) for the exact arrangement. Use a special wrench to put the ready-assembled packing gland into the body.

**The assembly of the sampling valve is now completed.**

## 4. Troubleshooting

The action to be taken in the event of malfunction is described in the operating instructions of the sampling valve. You can also contact Pfeiffer Chemie-Armaturenbau GmbH directly if you require help.

## 5. Repairing the valve

### 5.1 Replacing the V-ring packing

Should the ball valve leak at the packing, the V-ring packing ( 5 ) needs replacing as follows:

- Use a special wrench to undo the packing gland ( 3 ) and remove it.
  - Check the bearing bushing ( 4 ) and retaining ring ( 3a ) for any damage and replace with new parts, if necessary.
  - Remove the set of Belleville spring washers ( 7 ).
  - Take out the packing follower.
  - Carefully remove the PTFE V-rings ( 5 ) out of the packing chamber of the valve body.
  - Check the V-rings for damage, and, in case of doubt, replace with new ones.
- Reassembling the valve
  - Proceed in the reverse order to reassemble the valve. Refer to the instructions ( section 3 ) for any missing details or descriptions.

### 5.2 Replacing the sealing ring and ball

If the ball valve does not shut-off tightly, remove the sealing ring ( 6 ) and ball ( 2 ) as described in following to check them:

- Removing the sealing ring.
  - Unscrew the cheese-head screws ( 9 ).
  - Carefully lift off bonnet ( 8 ).
  - Remove sealing ring ( 6 ), check it for damage and replace it with a new one, if necessary.
- Removing the ball
  - Use a special wrench to undo the packing gland ( 3 ) and remove it.
  - Remove the set of Belleville spring washers ( 7 ).
  - Remove the packing follower.
  - Carefully remove the PTFE V-rings ( 5 ) out of the packing chamber of the valve body.
  - The ball ( 2 ) is now accessible in the body and can be carefully removed. Check ball for damage and replace with a new one, if necessary.
- Reassembling the valve
  - Proceed in the reverse order to reassemble the valve. Refer to the instructions ( section 3 ) for any missing details or descriptions.

## 6. Operating the sampling valve

### 6.1 Important general instructions



It may be necessary to clean the sampling chamber and the blind hole after a sample has been taken depending on the process medium used. The user must decide whether this action is necessary.

- Make absolutely sure that only vessels adapted to the medium temperature are used!
- Safety precautions need to be taken when the medium temperature exceeds 60 °C since a risk of scalding exists.
- On taking samples, strictly adhere to the generally valid precautions to be taken to prevent accidents!

### 6.2 Sampling valve with lever

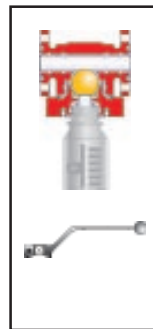

- Screw on the sample bottle tightly as far as it will go by hand.
- Turn lever by 180° to open the valve.
- Turn back the lever and let the sample flow into the bottle.
- Repeat this procedure until the required quantity of medium has been collected in the bottle.
- Unscrew the sample bottle, and seal with lid, if necessary.

### 6.3 Sampling valve with lever and protective case



- Open protective case.
- Screw on the sample bottle tightly as far as it will go by hand.
- Close protective case.
- Turn lever by 180° to open the valve.
- Turn back the lever and let the sample flow into the bottle.
- Repeat this procedure until the required quantity of medium has been collected in the bottle.
- Open protective case, remove sample bottle, and seal with lid, if necessary.
- Close protective case.

# Sampling Valve Series 27d

## 6.4 Sampling valve with lever and protective case with support

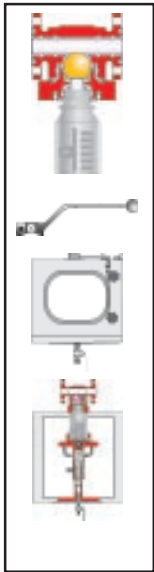

- Open protective case.
- Use grip to pull down the support.
- Place the sample bottle into the PTFE seat of the support.
- Guide the support upwards.
- Close protective case.
- Turn lever by 180° to open the valve.
- Turn back the lever and let the sample flow into the bottle.
- Repeat this procedure until the required quantity of medium has been collected in the bottle.
- Open protective case, guide the support downwards, remove sample bottle, and seal with lid, if necessary.
- Close protective case.

## 6.5 Sampling valve with automated 180° rotary actuator and protective case

### 6.5.1 General automated sampling

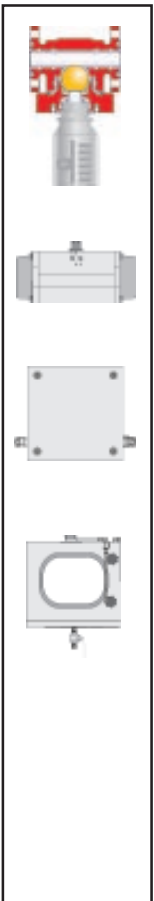

- Open protective case.
- Screw on the sample bottle tightly as far as it will go by hand.
- Close protective case.
- Open the supply air valve at the automation unit.
- **Note:** Refer to the operation of the corresponding automation unit in its instructions section 7 ( operation of automation units ).
- Close the supply air valve at the automation unit.
- Open protective case, remove sample bottle, and seal with lid, if necessary.
- Close protective case.

### 6.5.2 Automated sampling with back pressure indication

- Operation of this type of sampling is identical to the operating instructions described in section 6.5.1
- In addition to the above mentioned version, it features the following function:
  - The automation is switched off and no further sample can be taken when the sample level in the glass bottle reaches the back pressure tube.



On attaching the bottle, make sure that the back pressure tube is not bent!

### 6.5.3 Automated sampling with pneumatic barrier

- Operation of this type of sampling is identical to the operating instructions described in section 6.5.1
- In addition to the above mentioned version, it features the following function:
  - The automation is switched off and no further sample can be taken when the protective case is opened while sampling is taking place.

## 6.6 Sampling valve with automated 180° rotary actuator and protective case with support

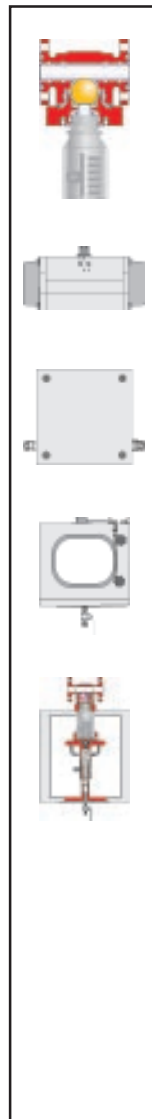

### 6.6.1 General automated sampling

- Open protective case.
- Use grip to pull down the support.
- Place the sample bottle into the PTFE seat of the support.
- Guide the support upwards.
- Close protective case.
- Open the supply air valve at the automation unit.
- **Note:** Refer to the operation of the corresponding automation unit in its instructions section 7 (operation of automation units).
- Close the supply air valve at the automation unit.
- Open protective case, remove sample bottle, and seal with lid, if necessary.
- Close protective case.

### 6.6.2 Automated sampling with back pressure indication

- Operation of this type of sampling is identical to the operating instructions described in section 6.6.1
- In addition to the above mentioned version, it features the following function:
  - The automation is switched off and no further sample can be taken when the sample level in the glass bottle reaches the back pressure tube.



On attaching the bottle, make sure that the back pressure tube is not bent!

### 6.6.3 Automated sampling with pneumatic barrier

- Operation of this type of sampling is identical to the operating instructions described in section 6.6.1
- In addition to the above mentioned version, it features the following function:
  - The automation is switched off and no further sample can be taken when the protective case is opened while sampling is taking place.



Note! Activate the emergency button in the event a fault should occur during sampling.

### 7.3 Automation with counter and time switch

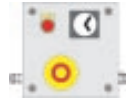

Note: The pulse timing of actuation as well as the timing for filling the actuator with air or venting it are default settings. Any alterations to these settings may only be made after consulting Pfeiffer Chemie-Armaturenbau GmbH first!

- Set the interval between each actuation cycle at the time switch.

## 7. Operation of automation units

### 7.1 Automation with ON/OFF switch

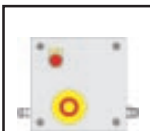

Note: The pulse timing of actuation as well as the timing for filling the actuator with air or venting it are default settings.

Any alterations to these settings may only be made after consulting Pfeiffer Chemie-Armaturenbau GmbH first!

- Press the start button. A complete actuating cycle to take a sample is performed.
- Repeat this procedure until the required quantity of medium has been collected in the bottle.

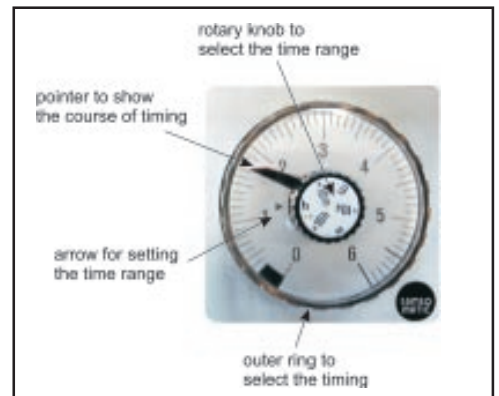

Fig. 4 - Samsomatic – Time Switch 3970

- Select time range. Switch over the time range at the rotary knob located in the center of the time dial by setting the arrow to the required range.

Selection	Time range
s	0,3 bis 6 seconds
x10s	3 bis 60 seconds
m	0,3 bis 6 minutes
x10m	3 bis 60 minutes
h	0,3 bis 6 hours
x10h	3 bis 60 hours

Table 2 – Time ranges

- Determine which timing you require. Turn the outer ring to set the required timing. A pointer shows the course of time.
- Set the number of actuation cycles at the counter.



Note: Select the number of actuating cycles appropriate to the sample bottle's volume.

### 7.2 Automation with counter

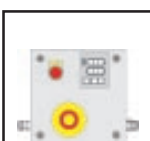

Note: The pulse timing and intervals between actuation cycles as well as the timing for filling the actuator with air or venting it are default settings.

Any alterations to these settings may only be made after consulting Pfeiffer Chemie-Armaturenbau GmbH first!

- Set the number of actuating cycles at the counter.



Note: Select the number of actuating cycles appropriate to the sample bottle's volume.

- Press the start button. The selected number of actuating cycles to take samples are performed.
- The sampling finishes automatically after the selected number of actuating cycles have been completed.

## Sampling Valve Series 27d

- Press the start button.  
The selected number of actuating cycles to take samples with the selected intervals in-between are performed.
- The sampling finishes automatically after the selected number of actuating cycles have been completed.



**Note!** Activate the emergency button in the event a fault should occur during sampling.



## 9. Customer inquiries

Details as per the check list for repairs and inquires.

Check list for repairs and inquires for the Sampling Valve Series 27d	
<b>General</b>	Order number (embossed on the type plate) _____ Customer: _____ Phone: _____ Fax: _____
<b>Medium</b>	Medium: _____ Temperature: _____ °C op. pressure: _____ bar Viscosity: <input type="checkbox"/> like water <input type="checkbox"/> like honey <input type="checkbox"/> like oil <input type="checkbox"/> others: _____ Property: <input type="checkbox"/> toxic <input type="checkbox"/> caustic <input type="checkbox"/> corrosiveness <input type="checkbox"/> abrasiv <input type="checkbox"/> foaming <input type="checkbox"/> others: _____
<b>Valve</b>	Nominal size: <input type="checkbox"/> DN 25 <input type="checkbox"/> DN 50 <input type="checkbox"/> sampling volume 1 to 13 ml _____
<b>Option</b>	Ball: <input type="checkbox"/> nickel alloys <input type="checkbox"/> titanium <input type="checkbox"/> others: _____ <input type="checkbox"/> zirkonium oxid <input type="checkbox"/> titanium 0,2% Pd others: <input type="checkbox"/> heating jacket <input type="checkbox"/> others: _____
<b>Garniture</b>	Bottle connection: <input type="checkbox"/> DURAN GL45 <input type="checkbox"/> adaption for: _____ <input type="checkbox"/> others: _____
<b>Add-On Components</b>	Protection box: <input type="checkbox"/> standard <input type="checkbox"/> 1"venting <input type="checkbox"/> support (not for bayonet locking) <input type="checkbox"/> others: _____ Automation: <input type="checkbox"/> with counter <input type="checkbox"/> on / off <input type="checkbox"/> time switch Operation: <input type="checkbox"/> multi-turn actuator (DAP60-180° or DAP100-180°) <input type="checkbox"/> hand-lever <input type="checkbox"/> actuator brand name: _____ type: _____ Sample bottle: <input type="checkbox"/> sample bottle DIN 4796 GL45 DURAN clear glass <input type="checkbox"/> will disposed by the cultomer <input type="checkbox"/> others: _____ others: _____ _____ _____

Table 3 – Check list

For your special requirements please contact our technical sales department

# Pfeiffer Chemie-Armaturenbau GmbH

Hooghe Weg 41 • 47906 Kempen  
Telefon: +49 21 52 20 05 - 0 • Telefax: +49 21 52 15 80  
E-Mail: vertrieb@pfeiffer-armaturen.com • Internet: www.pfeiffer-armaturen.com

Specifications subject to change without notice