

Continuous Sampling valve Series 27f

Application

Tight-closing inline sampling valve designed for continuous sampling of liquids from flowing media with variable sample volume.

Particularly suitable for media in over-pressure range:

- nominal diameters DN 25 to DN 100,
- nominal pressure PN 10 / 16
- temperatures -20°C to 200°C.

The valve consists of a continuous stainless steel sampling valve and a star grip for actuation.

The modular design has the following characteristics:

- body of stainless steel (1.4571),
- plug of stainless steel (1.4571),
- sampling with a variable sample volume from a material flow,
- representative sampling due to direct installation in the pipeline,
- no fore- and no after-running,
- plug shaft sealing by means of a cup spring pre-loaded PTFE packing with a tightenable stuffing box,
- face to face as per DIN EN 558-1, row 1 (DIN 3202, F1)



Fig. 1 - Series 27f Sampling Valve (DN 25)

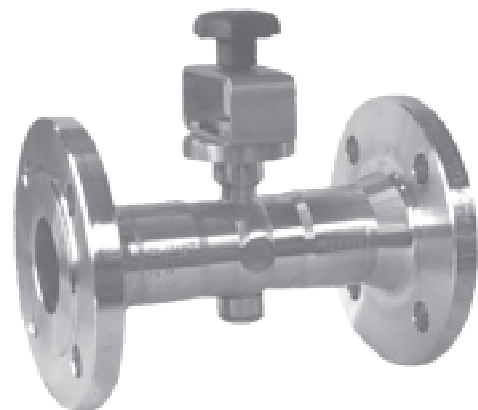

Fig. 2 - Series 27f Sampling Valve (DN 50)

Sampling Valve Series 27f

Special designs

- body, seat and plug of special materials (e.g. Hastelloy etc.),
- special face to face sizes
- heating jacket

Designs:

Continuous stainless steel sampling valve BR 27f available in the following designs:

- stainless steel sampling valve with star grip
- stainless steel sampling valve with dead man's handle

Options and add-on components:

For the control devices, the following accessories are available individually or in combinations:

- dead man's handle,
- protective box in stainless steel, also available with special gas chamber exhaust,
- support in protective box for an easy change of bottles,
- special flushing devices,
- sampling vessel connection as per ISO 4796,
- adapter for locally employed sample containers,
- pneumatic overflow control

other add-on parts are available as per specification on request

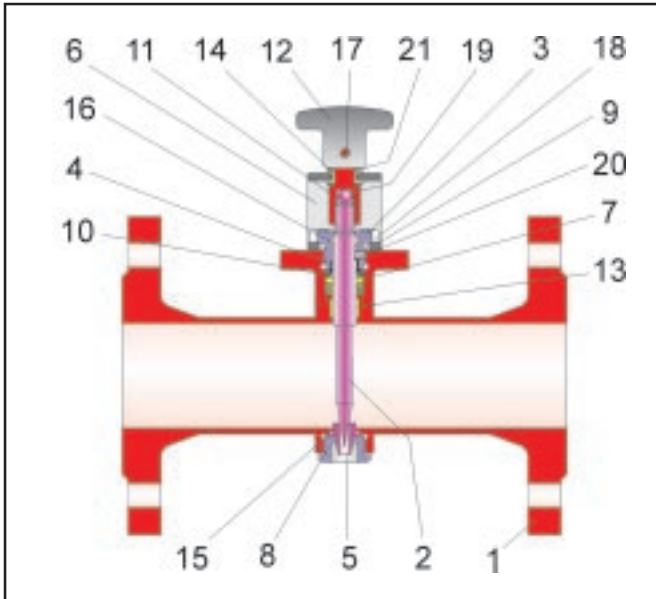

Fig. 3 - Series 27f Sampling Valve (DN 50)

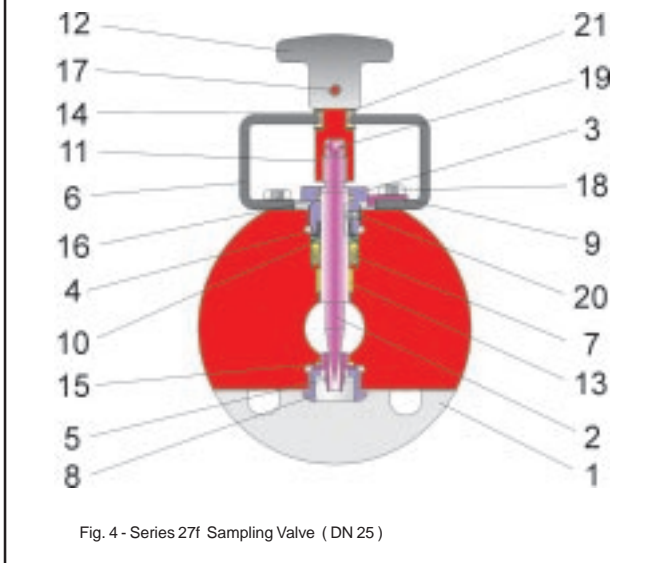

Fig. 4 - Series 27f Sampling Valve (DN 25)

Item	Description	Item	Description
1	Valve body	12	Star grip
2	Spindle	13	Bearing bushing
3	Stuffing box	14	Beating bushing
4	Bearing bushing	15	PTFE-ring
5	Seat	16	O-ring
6	Yoke	17	Threaded pin
7	V-ring packing	18	Screw
8	Threaded bushing	19	Ball
9	Locking piston	20	Threaded pin
10	Spring washer	21	Springwasher
11	Threaded guide		

Table 1 - List of parts

General technical data:

Nominal size	DN 25 to DN 100
Nominal pressure	PN 10 / 16
Temperature range	-20°C to 200°C
Leakage rate	Leakage rate A acc. to DIN EN 12266-1, P12 (Leakage rate 1 BO acc. to DIN 3230 Part 3)
Flanges	DIN-Versions and welding ends
Flange connection	free funnel

Table 2 - Technical data

Materials:

Valve body	1.4571
Plug	1.4571
Seat	1.4571
Stuffing box packing	PTFE
Lower bearing bushing	PTFE with 25% glass
Upper bearing bushing	PTFE with carbon

Table 2 - Materials

Description of the valve:

The sampling valve of the Series 27f is designed for continuous sampling.

By means of a star grip (12), a spindle (2) is lifted out of the seat (5) and the medium can flow through the annular gap into the sampling vessel held below.

The sealing in the seat is metallic.

The spindle sealing is by means of a cup spring pre-loaded PTFE packing (7) with an additional tightenable stuffing box (3).

The sampling valve is suitable for liquid media in the range of over-pressure.
(In the case of underpressure, please ask for the BR27a)

All materials employed are of 1.4571.

The sampling valve is supplied as standard with flanges or optionally with welding socket pieces.



Caution: Particular attention must be paid to the fact that only temperature-adapted vessels are employed for sampling!



Caution: In case of media temperatures above 60°C, safety precautions are to be taken due to the risk of scalding.



Note: The generally valid regulations for prevention of accidents when taking samples are to be strictly observed!



Note: Please, pay attention to the usability acc. to the ATEX 94/9/EG in correspondance to the maintenance sheet before using the ball valve in hazardous area!



Note: Due to the fact off continuous sampling there is a rish to overfill the sample bottle. This demands the use of death man´s handle to operate the valve. This secures to stop flow off product immedietly with end off manual operation.

Pressure - Temperature - Diagram:

The operating range is determined by the pressure - temperature – diagram. Process data and media can influence the values of the diagram. For process data outside the limits of application, please consult us.

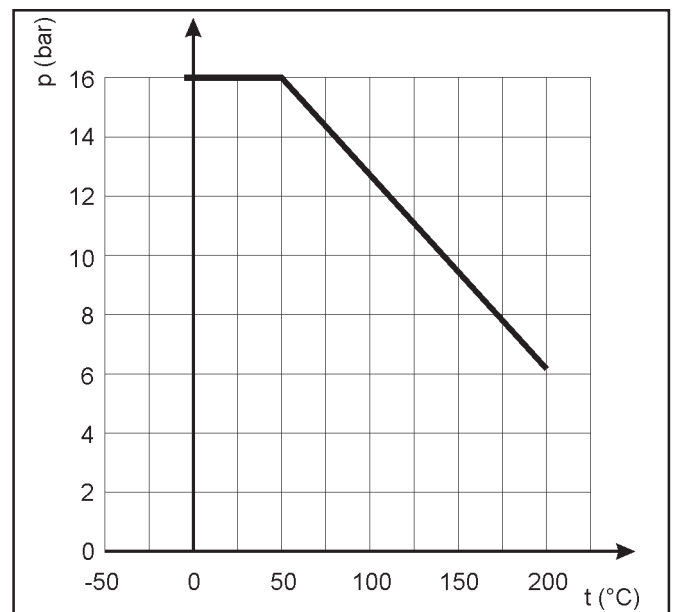

Fig. 5 - Pressure-Temperature-Diagram

Dimensions:

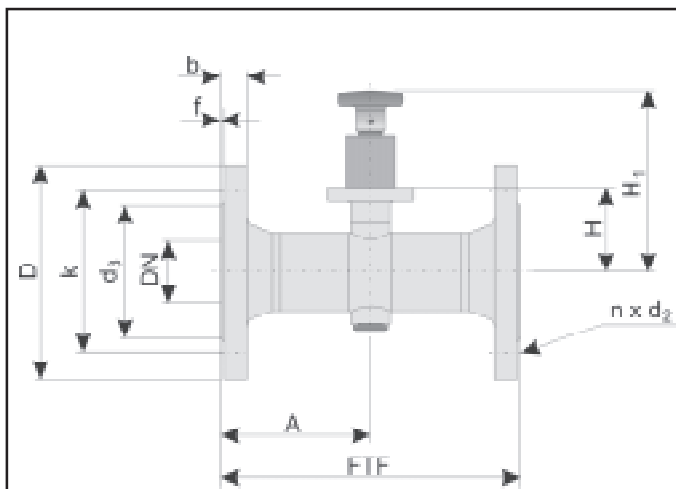

Fig. 6 – Dimensional drawing of the sampling valve (from DN 50)

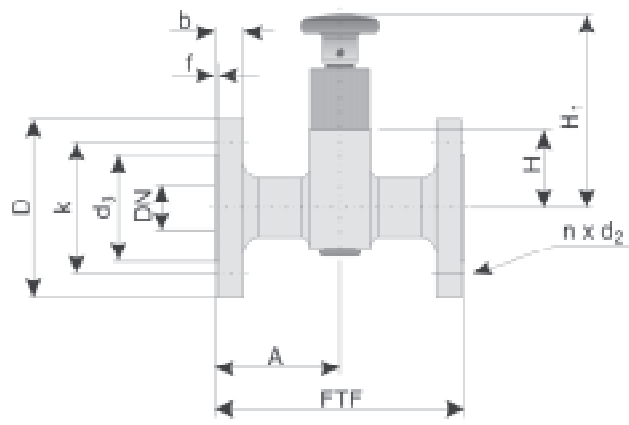

Fig. 7 – Dimensional drawing of the sampling valve (DN 25)

DN	25	50	80
FTF	160	230	310
A	80	115	155
D	115	165	200
k	85	125	160
d3	68	102	138
b	18	20	20
f	2	3	3
n x d2	4 x 14	4 x 18	4 x 18
H	50	65	80
H1	125	140	155

Table 4 - Dimensions in mm

Selection and sizing of the sampling valve:

1. Determination of the required nominal diameter
2. Selection of the valve in accordance with table 1, table 2 and the pressure-temperature-diagram.
3. Additional equipment.

Order text:

Sampling valve type: Series 27f,
DN / PN poss. special design
Star grip or dead man's handle,
Medium , temperature , viscosity ,
Property , sampling vessel connection ,
Additional equipment ,
Other ,

For your special requirements please contact our technical sales department

Pfeiffer Chemie-Armaturenbau GmbH

Hooghe Weg 41 • 47906 Kempen • Germany
Telefon: +49 2152 2005 - 0 • Telefax: +49 2152 1580
E-Mail: vertrieb@pfeiffer-armaturen.com • Internet: www.pfeiffer-armaturen.com

Specifications subject to change without notice