

# Stainless Steel Sampling Valve Series 27g

## Application

Tight-closing cavity-free inline valve for vertical installation designed to sample liquids from flowing media. Particularly suitable for aggressive media in process plants:

- nominal diameters DN 25 and DN 50,
- nominal pressure PN 10/16 ( PN 40 on request )
- temperatures -20°C to 200°C.

The **discontinuous** sampling valve **Series 27g** has the following characteristics:

- sampling with a defined sample volume from a material flow,
- diverse sample volumes
- in the case of liquid media, depressurised sampling and therefore sampling at high pressures and from vacuum permissible,
- no fore- and no after-running,
- no risk of overflow as the sample volume is determined per stroke,
- no direct connection to the environment,
- no false operation due to long opening times.

The valve consists of a sampling valve and a pneumatic quarter-turn actuator or a hand-lever. This modular design has the following characteristics:

- body of stainless steel ( 1.4571 ),
- ball / shaft of stainless steel ( 1.4571 ),
- representative sampling due to the direct installation in the pipeline,
- no abrasion of the pipeline during sampling,
- venting resp. control connection 1/8"
- sealing shells for a sampling without cavity,
- the sampling valve has a connection as per ISO 4796 DIN thread GL 45,
- ball stem sealing by means of a cup spring pre-loaded PTFE packing.
- connection as per DIN / ISO 5211
- continuous sampling optionally available

The optional **continuous** sampling valve **Series 27g** has the following characteristics:

- sampling with a variable sample volume from a material flow,
- sampling also possible under pressure to 16 bar,
- as standard with dead man's handle



Fig. 1 - Series 27g Sampling Valve with heating jacket

# Sampling Valve Series 27g

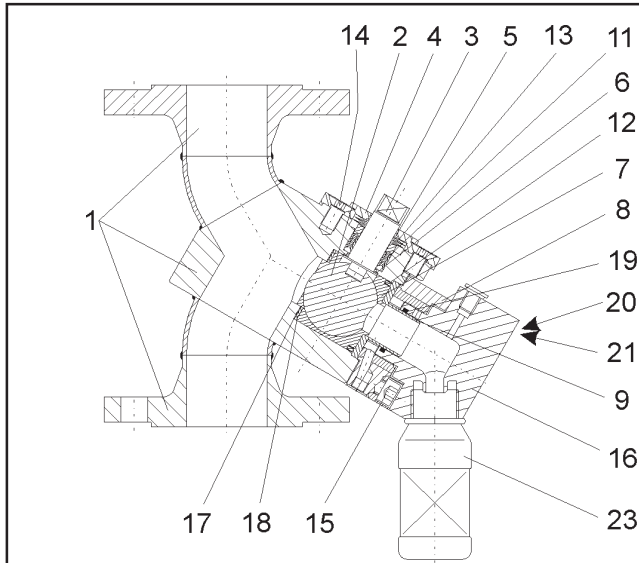

Fig. 2 – Discontinuous sampling valve BR 27g

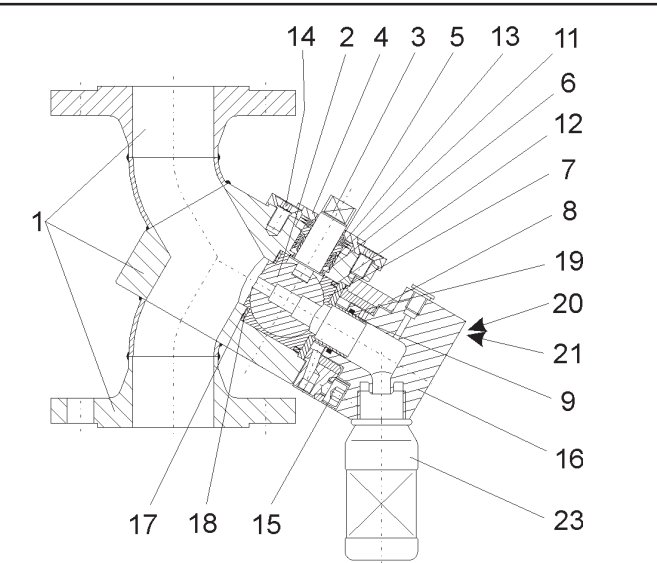

Fig. 3 – Continuous sampling valve BR 27g

Item	Description	Item	Description
1	Valve body	13	Set of spring washers
2	Ball	14	Screw
3	Control shaft	15	Screw
4	Stuffing box flange	16	Sample adapter
5	Bearing bushing	17	Washer
6	Bearing bushing	18	Spring washer
7	Sealing ring	19	O-ring
8	Bonnet	20	Screw
9	Funnel	21	Washer
11	V-ring packing	23	Sample bottle
12	O-ring		

Table 1 – Parts list

## Designs:

Stainless steel sampling valve available in the following designs:

- with hand lever ( discontinuous ),
- automatic with 180° quarter-turn actuator ( discontinuous ),
- with dead man's handle ( continuous ),
- automatic with 90° quarter-turn actuator ( continuous ),  
(for details see respective data sheet).

## Options and add-on components:

For the sampling valve, the following accessories are available individually or in combinations:

- protective box in stainless steel,
  - special gas chamber exhaust,
  - pneumatic switchbox for automation,
  - support in protective box for an easy change of bottles,
  - pneumatic timer,
  - counter
  - special flushing devices,
  - pneumatic overflow control,
  - adapter for locally employed sample containers,
- Other add-on parts are available on request

## Special designs

- body and ball of special materials ( e. g. Hastelloy ),
- special face to face sizes
- heating jacket,
- high pressure version
- high temperature version

## General technical data:

Nominal size	DN 25 and DN 50
Nominal pressure	PN 10 / 16
Temperature range	-20°C to 200°C
Leakage rate	Leakage rate A acc. to DIN EN 12266-1, P12 (Leakage rate 1 BO acc. to DIN 3230 Part 3)
Flange connections	all DIN - Versions
Bottle connection	GL 45 acc. ISO 4796

Table 2 – Technical data

## Materials:

Body	1.4571
Ball with shaft	1.4571
Sealing ring	TFM (PTFE)
Sealing ring inlet	TFM (PTFE)
Stuffing box packing	PTFE - V-ring-packing with cup springs of WN 1.8159, Delta Tone
Lower bearing bushing	PTFE with glass
Upper bearing bushing	PTFE with carbon
Body sealing	Viton O-ring
Sample bottle	Glass

Table 3 - Materials

### Description of the valve:

The sampling valve is installed in the vertical product pipeline by means of flanges.

Due to the concave milling-out of the ball ( 2 ), there is no necking in the area of the medium flow.

The ball is surrounded on all sides by tight-closing sealing ( 7 ) elements.

The sealing of the ball is by means of an exchangeable PTFE sealing ring. This can also be specially adapted to the medium.

The ball (2) is bearing-mounted and rotatable around the shaft. The outward-leading stem is fitted as standard with a hand lever resp. dead man's handle. The connection according to DIN-ISO 5211 permits the fitting of an actuator.

The sealing of the stem is ensured by means of a PTFE packing ( 11 ). The packing is maintenance-free pre-loaded via cup springs ( 13 ).

The glass vessel ( 23 ) has a connection in accordance with ISO 4796 thread GL 45. Customer-specific adapters for other connections can also be offered.



**Caution:** Particular attention must be paid to the fact that only temperature-adapted vessels are employed for sampling!



**Caution:** In case of media temperatures above 60°C, safety precautions are to be taken due to the risk of scalding.



**Note:** The generally valid regulations for prevention of accidents when taking samples are to be strictly observed!



**Note:** Please, pay attention to the usability acc. to the ATEX 94/9/EG in correspondance to the maintenance sheet before using the ball valve in hazardous area!



**Note:** Due to the fact of continuous sampling there is a risk to overflow the sample bottle. This demands the use of death man's handle to operate the valve. This secures to stop flow off product immediately with end off manual operation.

### Pressure - Temperature - Diagram:

The operating range is determined by the pressure - temperature - diagram. Process data and medium can influence the values of the diagram.

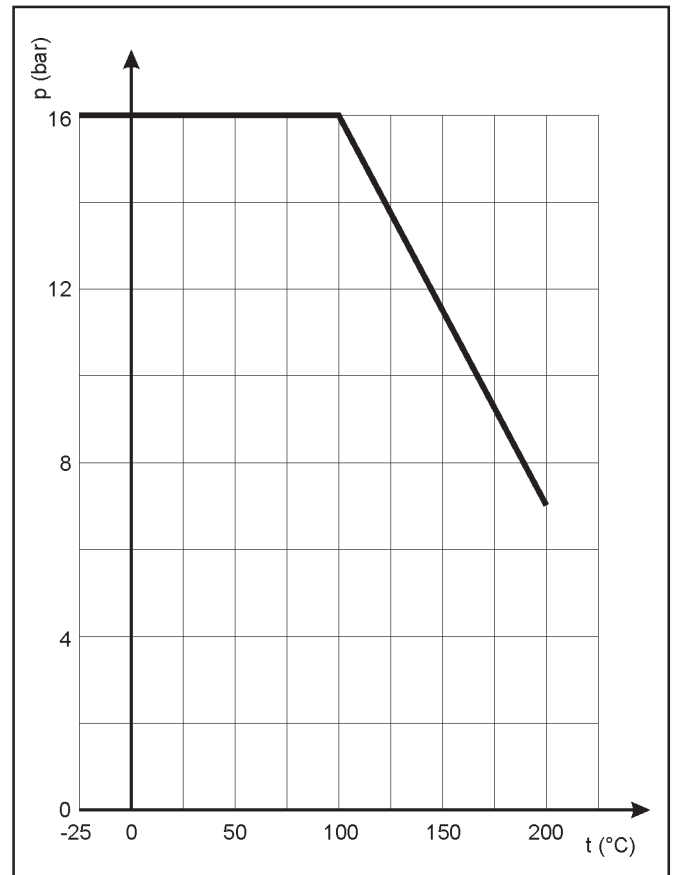

Fig. 4 - Pressure-Temperature-Diagram

### Operating and breakaway torques:

Differential pressure $\Delta p$ in bar		0	5	10	15	20	25	30	40
DN	perm. operating torque $M_{dmax}$ in Nm	breakaway torque $M_{di}$ in Nm							
25 up to 50	226	15	22	29	36	43	50	56	68

Table 4 - Max. permissible operating torque, required operating torques and breakaway torques.

The breakaway torques indicated are average values which were measured at the appropriate differential pressures with air at 20°C. Operating temperature, medium as well as longer periods of operation can lead to a notable change in breakaway and operating torques.

The listed max. permissible operating torques are valid for the standard materials in table 3.

## Dimensions and weights:

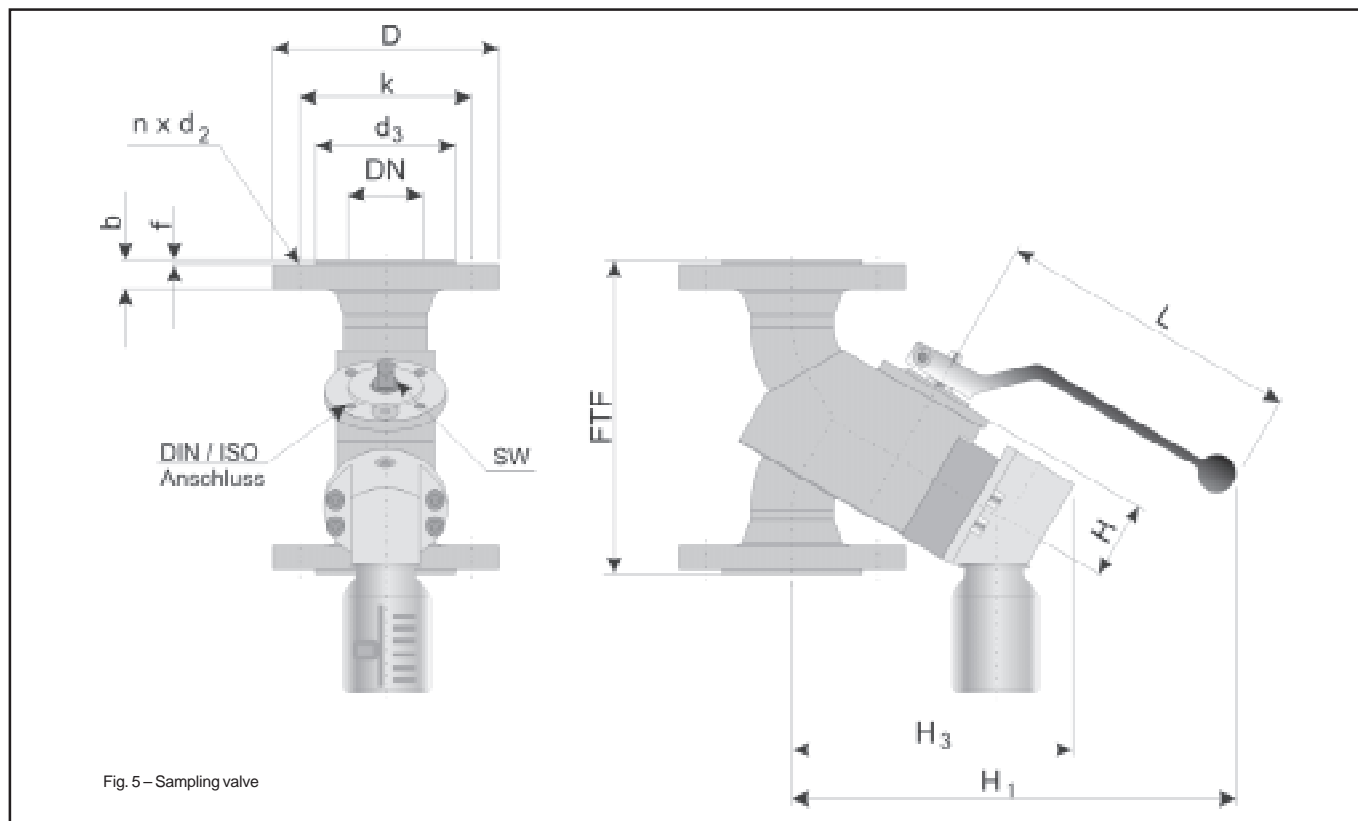

Fig. 5 – Sampling valve

DN	25	50
FTF	230	230
D	115	165
k	85	125
d3	68	102
b	18	20
f	2	3
n x d2	4 x 14	4 x 18
H	57,5	57,5
H1	321	321
H3	206	206
L	220	220
SW	12	12
DIN ISO Connection	F07	F07
Weight in kg	11	14

Table 5 - Dimensions in mm and weights in kg

### Selection and sizing of the ball valve:

1. Determination of the required nominal diameter
2. Selection of the valve in accordance with table 2, table 3 and the pressure-temperature-diagram.
3. Choice of the appropriate actuator in accordance with table 4.
4. Additional equipment.

### Order text:

Sampling valve Series 27g  
 DN . . . . . / PN . . . . . poss. special design  
 Possible sampling volumes. . . . .,  
 Hand lever resp. dead man's handle or automation,  
 Medium . . . . ., temperature . . . . ., viscosity . . . . .,  
 Property . . . . ., sampling vessel connection . . . . .,  
 Additional equipment . . . . .,  
 Other . . . . .,

For your special requirements please contact our technical sales department

## Pfeiffer Chemie-Armaturenbau GmbH

Hooghe Weg 41 • 47906 Kempen • Germany  
 Phone: +49 2152 2005 - 0 • Fax: +49 2152 1580

E-Mail: [vertrieb@pfeiffer-armaturen.com](mailto:vertrieb@pfeiffer-armaturen.com) • Internet: [www.pfeiffer-armaturen.com](http://www.pfeiffer-armaturen.com)

Specifications subject to change without notice