

PFA – lined Sampling Valve Series 271 / Series 27m

Application

Tight-closing cavity-free endline PFA-lined valve designed to sample liquids from flowing media without bypass. Particularly suitable for aggressive media in process plants:

- nominal diameters DN 25 and DN 50,
- nominal pressure PN 10/16
- temperatures -10°C to 200°C.

The **discontinuous** sampling valve **Series 271** has the following characteristics:

- sampling with a defined sample volume,
- diverse sample volumes
- in the case of liquid media, depressurised sampling and therefore sampling from pressures to 16 bar and from vacuum permissible,
- no fore- and no after-running,
- no risk of overflow as the sample volume is determined per stroke,
- no direct connection to the environment,
- no false operation due to long opening times.

The **continuous** sampling valve **Series 27m** offers the following features:

- sampling with a variable sample volume,
- sampling also possible under pressure to 16 bar,
- as standard with dead man's handle

Both valves consist of a sampling valve and a pneumatic quarter-turn actuator or a hand-lever resp. dead man's handle.

This modular design has the following characteristics:

- body of EN-JS 1049 with PFA lining,
- ball and stem one-piece in stainless steel, 1.4313 / PFA-jacket
- representative sampling due to the direct installation in the pipeline,
- venting resp. control connection 1/4"
- sealing shells for a sampling without cavity,
- the sampling valve has a connection as per ISO 4796 DIN thread GL 45,
- ball stem sealing by means of a cup spring pre-loaded PTFE packing.
- connection as per DIN ISO 5211



Fig. 1 - Series 271/27m Sampling Valve

Sampling Valve Series 27I / 27m

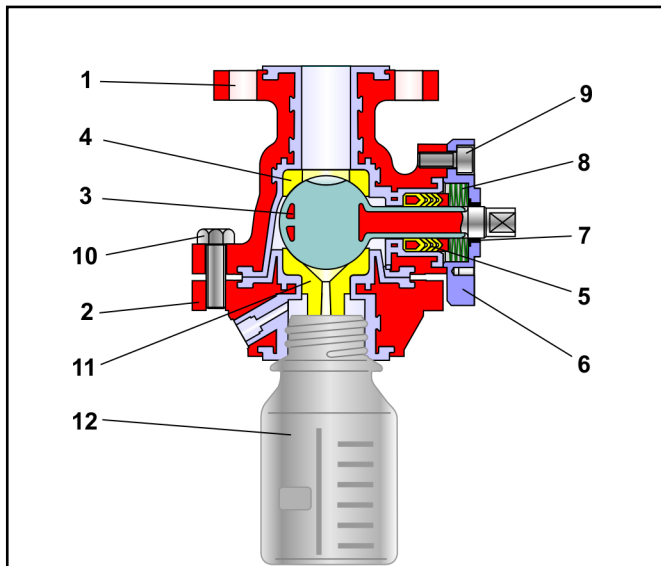

Fig. 2 - discontinuous Sampling Valve Series BR 27I

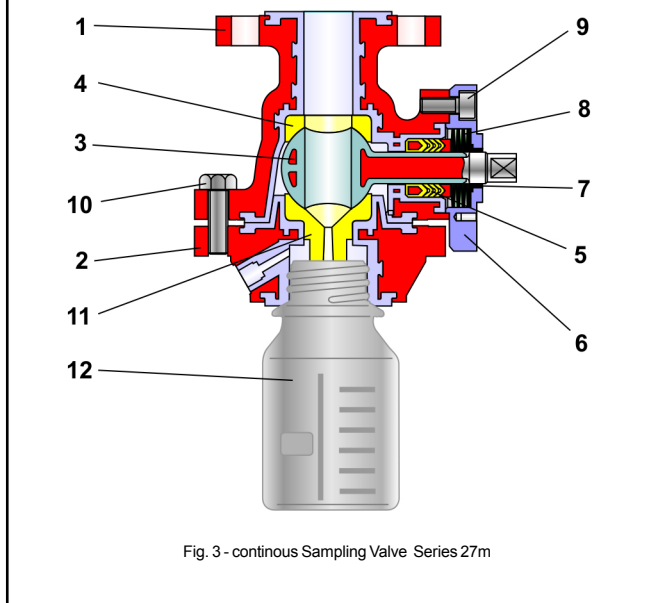

Fig. 3 - continuous Sampling Valve Series 27m

| Item | Description | Item | Description |
|------|---------------------|------|-----------------------|
| 1 | Valve body | 7 | Bearing bushing |
| 2 | Body | 8 | Set of spring washers |
| 3 | Ball | 9 | Screw |
| 4 | Seat ring | 10 | Screw |
| 5 | V-ring packing | 11 | Seat ring |
| 6 | Stuffing box flange | 12 | Sample bottle |

Table 1 - List of parts

Designs:

PFA-lined sampling valve available in the following designs:

- with hand lever (BR 27I),
 - automatic with 180° quarter-turn actuator (BR 27I),
 - with dead man's handle (BR 27m),
 - automatic with 90° quarter-turn actuator (BR 27m),
- (for details see respective data sheet).

Special designs

- diverse materials for ball and sealing ring,
- heating jacket

Options and add-on components:

For the sampling valve, the following accessories are available individually or in combinations:

- protective box in stainless steel,
- special gas chamber exhaust,
- pneumatic switchbox for automation,
- support in protective box for an easy change of bottles,
- pneumatic timer,
- counter
- special flushing devices,
- pneumatic overflow control,
- adapter for locally employed sample containers,

other add-on parts are available as per specification on request

General technical data:

| | |
|--------------------|---|
| Nominal size | DN 25 to DN 50 |
| Nominal pressure | PN 10/16 |
| Temperature range | -10°C to 200°C |
| Leakage rate | Leakage rate A acc. to DIN EN 12266-1, P12 (Leakage rate 1 BO acc. to DIN 3230 Part 3) |
| Flange connections | acc. to DIN EN 1092-1 (DIN 2632 / 2633) |
| Bottle connection | GL 45 acc. ISO 4796 |

Table 2 – Technical data

Materials:

| | |
|----------------------|---|
| Body | EN-JS 1049 (GGG 40.3) with PFA-lining |
| Ball with shaft | 1.4313 with PFA-coating |
| Sealing ring | PTFE |
| Sealing ring inlet | PTFE |
| Stuffing box packing | PTFE - V-ring-packing with cup springs of 1.8159, Delta Tone |
| Bearing bushing | PTFE with carbon |
| Coating | PVC black (RAL9005) |
| Sample bottle | Glass |

Table 3 - Materials

Description of the valve:

The sampling valves Series 27I / Series 27m are fitted to the product pipeline by means of the flange.

The ball is surrounded on all sides by tight-closing sealing (4) elements.

The sealing of the ball is by means of an exchangeable PTFE sealing ring. This can also be specially adapted to the medium.

The ball (3) is bearing-mounted and rotatable around the shaft.

The outward-leading stem is fitted as standard with a hand lever resp. dead man's handle.

The connection according to DIN-ISO 5211 permits the fitting of an actuator.

The sealing of the stem is ensured by means of a PTFE packing (5). The packing is maintenance-free pre-loaded via cup springs (8).

The glass vessel (14) has a connection in accordance with ISO 4796 thread GL 45. Customer-specific adapters for other connections can also be offered.



Caution: Particular attention must be paid to the fact that only temperature-adapted vessels are employed for sampling!



Caution: In case of media temperatures above 60°C, safety precautions are to be taken due to the risk of scalding.



Note: The generally valid regulations for prevention of accidents when taking samples are to be strictly observed!



Note: Please, pay attention to the usability acc. to the ATEX 94/9/EG in correspondance to the maintenance sheet before using the ball valve in hazardous area!



Note: Due to the fact off continous sampling there is a rish to overfill the sample bottle. This demands the use of death man's handle to operate the valve. This secures to stop flow off product immedietly with end off manual operation.

Pressure - Temperature - Diagram:

The operating range is determined by the pressure - temperature - diagram. Process data and media can influence the values of the diagram.

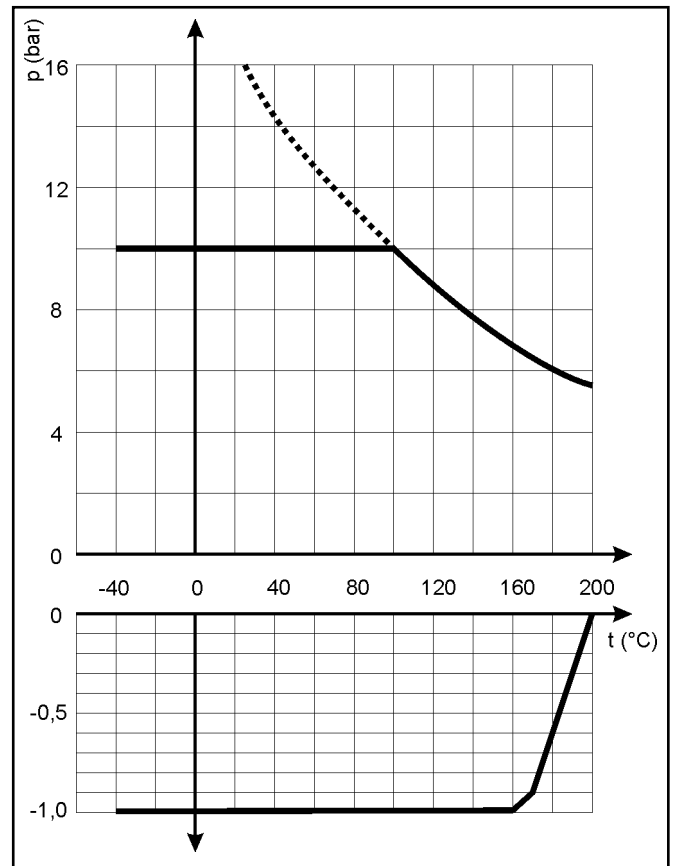

Fig. 4 - Pressure-Temperature-Diagram

Operating and breakaway torques:

| Differential pressure Δp in bar | | 0 | 5 | 10 | 16 | |
|---|---|-----------------------------------|---------------------------------|----|----|----|
| DN | perm. operating torque M_{Dmax} in Nm | req. operating torque M_d in Nm | breakaway torque M_{dI} in Nm | | | |
| | 25 | | 130 | 6 | 10 | 12 |
| 50 | 140 | 17 | 30 | 32 | 34 | 37 |

Table 4 - Max. permissible operating torque, required operating torques and breakaway torques.

The breakaway torques indicated are average values which were measured at the appropriate differential pressures with air at 20°C. Operating temperature, medium as well as longer periods of operation can lead to a notable change in breakaway and operating torques.

The listed max. permissible operating torques are valid for the standard materials in table 3.

Dimensions:

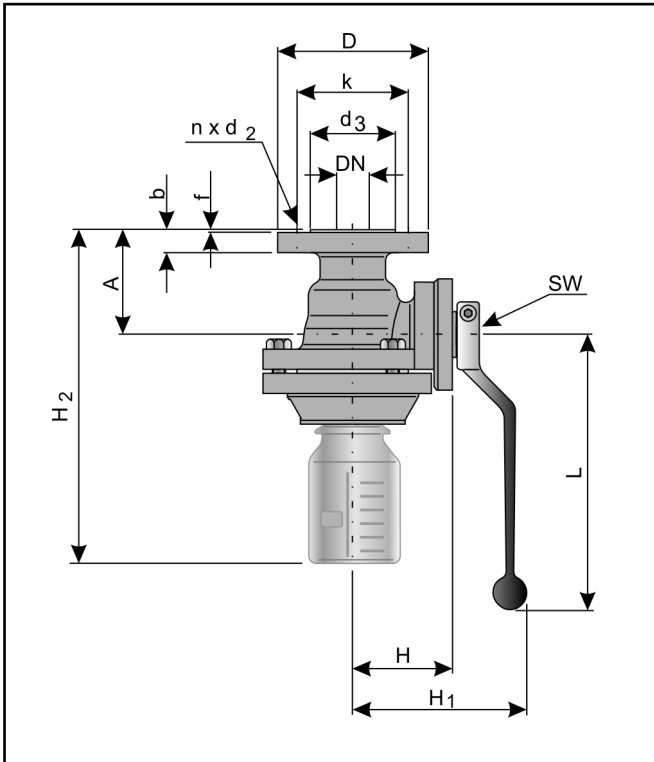

Fig. 5 – Sampling valve

Selection and sizing of the ball valve:

1. Determination of the required nominal diameter
2. Selection of the valve in accordance with table 2, table 3 and the pressure-temperature-diagram.
3. Choice of the appropriate actuator in accordance with table 4.
4. Additional equipment.

Order text:

Sampling valve Series 27I / Series 27m
 DN / PN poss. special design
 Possible sampling volumes. ,
 Hand lever resp. dead man's handle or automation,
 Medium , temperature , viscosity ,
 Property , sampling vessel connection ,
 Additional equipment ,
 Other ,



Note: All relevant details regarding the version ordered, which deviate from the specified version in this technical description data, can be taken if required, from the corresponding order confirm.

| | | | |
|--------------------|-----------------------|--------|-----|
| DN | 25 | 50 | |
| A | 80 | 115 | |
| D | 115 | 165 | |
| k | 85 | 125 | |
| d3 | 68 | 102 | |
| b | 18 | 21,5 | |
| f | 2 | 3 | |
| n x d2 | 4 x 14 | 4 x 18 | |
| H | 76 | 90 | |
| H1 | 142 | 164 | |
| H2 | Sample bottle 100 ml | 227 | 262 |
| | Sample bottle 250 ml | 267 | 302 |
| | Sample bottle 500 ml | 307 | 342 |
| | Sample bottle 1000 ml | 357 | 392 |
| L | 152 | 220 | |
| SW | 12 | 12 | |
| DIN ISO Connection | F05 | F07 | |

Table 5 - Dimensions in mm

For your special requirements please contact our technical sales department

Pfeiffer Chemie-Armaturenbau GmbH

Hooghe Weg 41 • 47906 Kempen • Germany
 Phone: +49 2152 2005 - 0 • Fax: +49 2152 1580

E-Mail: vertrieb@pfeiffer-armaturen.com • Internet: www.pfeiffer-armaturen.com

Specifications subject to change without notice