

Operation, assembly and maintenance instructions for continuous sampling valve Series 27f



Fig 1 - Sampling valve Series 27f



The equipment may only be dismantled and disassembled by skilled staff, who are familiar with the assembly, start-up, and the operation of this product.

Skilled staff in the sense of these repair and assembly instructions are persons who, as a result of their training, knowledge, and experience, also their knowledge of the relevant standards, are able to judge the tasks assigned to them, and are able to recognise possible dangers.

1. Design, operation and dimensions

Design, operation and dimensions, as well as all further technical details may be found in the **Data sheet < TB 27f_EN >** for sampling valve Series 27f.

2. Installation, start-up and maintenance

Guidelines for the installation, start-up and maintenance can be found in the respective operating instructions for sampling valves

0. Introduction

These instructions are intended to support the user in the assembly and repair of sampling valves of the series 27f.

Technical details, as a result of the further development of the valves mentioned in these instructions are subject to modification. The text and illustrations do not necessarily display the scope of supply, or an eventual order of spare parts. Drawings and graphics are not to scale. Customer related special designs, which are not in accordance with our standard offer, are not shown.

The transfer of these instructions to third parties is only allowed with the written approval of Pfeiffer Chemie-Armaturenbau GmbH. All documents are protected according to the laws of the German Copyright Act.

The transmission and/or duplication of documents, even in abstracts, also the exploitation and communication of their content is not permitted, unless expressly granted.

Violations are an offence and liable to claims for damages. We reserve all rights for the exercise of industrial property rights.

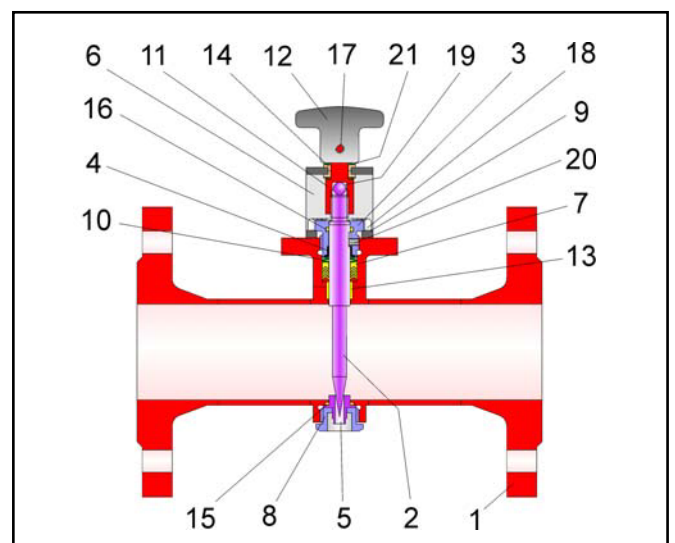

Fig. 2 - Sectional view of series 27f => Parts list see Table 1 on page 2

Sampling valve Series 27f

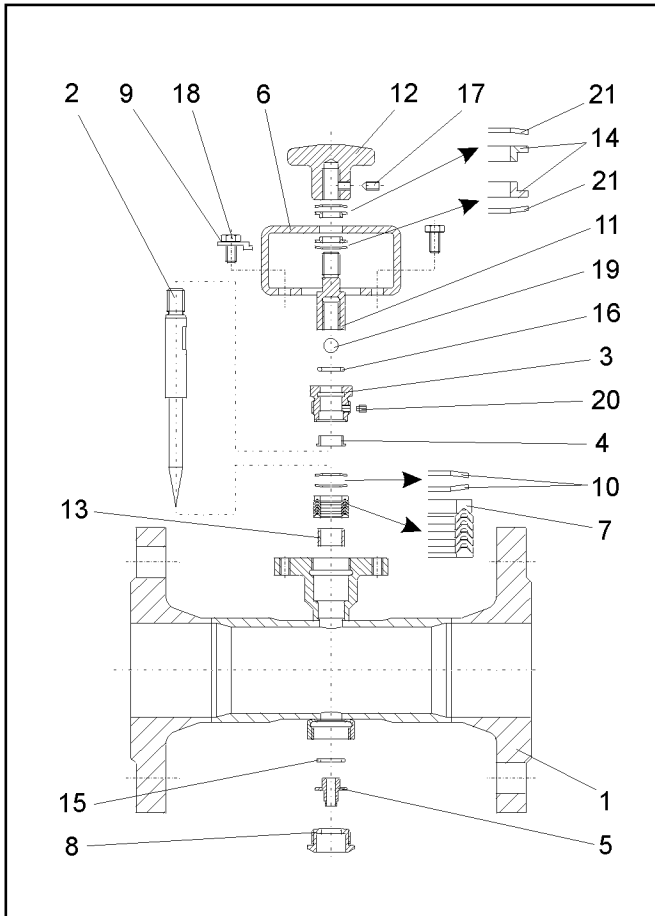

Fig. 3 - Explosion drawing of the sampling valve series 27f

Pos.	Qty.	Description	Material
1	1	Valve body	1.4571
2	1	Spindel	1.4571
3	1	Stuffing box	1.4305
4	1	Bearing bushing	PTFE with 25% carbon
5	1	Seat	1.4571
6	1	Yoke	1.4571
7	1	V-ring packing	1.4305 / PTFE
8	1	Threaded bushing	1.4571
9	1	Locking piston	1.4571
10	2	Spring washer	1.8159/Deltatone coated.
11	1	Threaded guide	1.4571
12	1	Star handle	Duroplast / steel
13	1	Bearing bushing	PTFE
14	2	Bearing bushing	PTFE with 25% carbon
15	1	PTFE-ring	PTFE
16	1	O-ring	Viton
17	1	Threaded pin	A2-70
18	2	Hexagon screw	A2-70
19	1	Ball	1.4301
20	1	Threaded pin	A2-70
21	2	Spring washer	1.4310

Table 1 - Parts list

3. Assembly of the sampling valve

3.1 Preparation for assembly

To assemble the sampling valve, clean all parts thoroughly, and lay them on a soft padding surface (rubber mat ect.) Take into consideration, that parts made of plastic are always soft and sensitive, and especially the sealing surfaces must not be damaged.



Note: The position and arrangement of the individual parts shown must be strictly adhered to on assembling the valve.

3.2 Initial assembly of the Stuffing box

The bearing bushing (4) and the O-ring (16) are pressed into the stuffing box (3). The stem of the spindle (2) is guided into the pre-assembled stuffing box, and positioned with the threaded pin (20). The threaded pin is hand tightened with an Allen key. Loosen the locking screw 1/8 of a turn. The coned shaft must now be easily moveable.

3.3 Initial assembly of the Yoke

Fit the bearing bush (14) in the inside and outside of the Yoke (6). Place the spring washers (21) on the threaded guide (11). Afterwards, insert the threaded guide through the bearing bush. Another spring washer (21) is then placed on the threaded guide. The location of the spring washer can be taken from the explosion drawing (Fig. 3). Screw the handle (12) tightly onto the threaded guide (11). After this, bore a 4,2mm hole x 10mm through the shaft of the handle into the threaded guide. Tap a M5 thread in the bore. Then with the locking screw (17) tighten the handle and the threaded guide together.

3.4 Assembly of the valve body

Clamp the valve body (1) with the adapter facing upwards in a vice. The bearing bush (13) is inserted into the adapter until it reaches the respective position in the valve body. Press the V-ring of the V-ring packing (7) in the body. After this, insert each ring separately, finishing with the stainless steel packing press ring.

Now, the spring washers (10) can be placed on the packing press ring.

For exact the positioning, and locating of the V-ring packing, and the spring washers, refer to the explosion drawing (Fig. 3).

Apply grease to the thread of the stuffing box, and insert into the valve body. Finally tighten to 5 Nm.

Apply grease to threaded end of the shaft (2) place the ball (19) on the shaft end. The guiding thread (11) of the pre-assembled yoke is then screwed hand tight onto the spindle.

Attention: Left handed thread!

The yoke and the valve body are then assembled together with two hexagon screws (18) and locking pistons (9).

3.5 Seat assembly

Now turn the valve body 180° and again clamp in the vice, so that the opening for the seat assembly is accessible. First insert the PTFE-ring (15) and then the seat (5) in the valve body.

Apply grease to the thread of the threaded sleeve (8) and tighten lightly with hand, then loosen 1/8 of a turn

Turn the handle and bring the coned shaft in the „CLOSED“ position. In this way, the seat is centered. The coned shaft then opens slowly, at the same time the threaded sleeve is drawn up so that the seat remains centered.

Now bring the shaft in the „OPEN“ position, following this, tighten the threaded bushing (8) 40 Nm.

The assembly of the sampling valve is now completed.

4. Trouble shooting

Action to be taken in the event of a malfunction is described in the operating instructions for sampling valves. You can also contact Pfeiffer Chemie-Armaturenbau GmbH directly if you require help.

5. Repairing the sampling valve

5.1 Replacing the V-ring packing

Should the sampling valve leak at the packing, the V-ring packing (7) must be replaced as follows:

- Loosen and remove the hexagon screws (18 + 9).
- Unscrew and remove the threaded guide (11) of the pre-assembled yoke.

Attention: Left handed thread!

- Now, loosen and remove the spindle carefully with the pre-assembled stuffing box.
- Remove the spring washer set (10).
- Remove the pressure ring of the V-ring packing.
- Carefully remove the PTFE - V-rings of the V-ring packing (7) from the packing chamber of the body.
- Check the V-rings for damage, and if necessary replace.

- Assembling the valve
- To reassemble the valve, proceed in reverse order to the instructions mentioned above.
For any missing descriptions, or details, refer to the assembly instructions in (Section 3).

6. Operating the sampling valve

6.1 Important general instructions

According to the medium being used, it may be necessary to clean the sampling chamber and blind hole after a sample has been taken. The operator must decide when and if this is necessary.

- It is absolutely important, that before taking a sample, the sampling container (glass bottle etc.) is adapted to the temperature of the media being taken!
- Safety precautions must be taken when the medium temperature exceeds 60°C as a possible risk of scalding
- When taking samples, the general accident prevention regulations must be complied with at all times!

6.2 Sampling with star handle

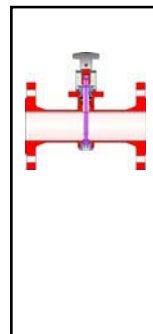

- Hold the sampling glass under the run-out piece, or optionally screw on the bottle by hand as tightly as possible.
- Turn the handle in anti-clockwise direction.
- Hold the valve in this open position until the required amount has been collected.
- Turn handle in clockwise direction and finish the sampling.
- If required seal the sampling bottle with a lid.

6.3 Sampling with „dead mans handle“

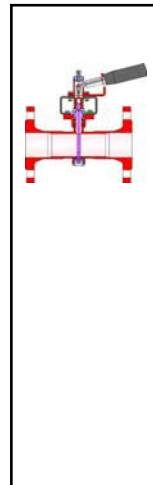

- Hold the sampling bottle under the run-out piece, or optionally screw on the bottle by hand as tightly as possible.
- Press the handle of the „automatic safety device“ downwards.
- Hold the valve in this position until the required amount has been collected.
- Return the „dead mans handle“ to the original position.
Do not release the hand lever abruptly while the medium is being collected, or at the end of sampling, as the automatic device will be activated and the sampling will stop automatically.
- If necessary seal the bottle with a lid.



7. Customer inquiries

Details as per check list for repairs and inquiries.

Check list for repairs and inquiries for the sampling valve series 27f	
General	Commission number: (embossed on the type plate _____ Kunde: _____ Telephone: _____ Fax: _____
Medium	Medium: _____ Temperature: _____ °C op pressure: _____ bar Viscosity: <input type="checkbox"/> like water <input type="checkbox"/> like honey <input type="checkbox"/> like oil <input type="checkbox"/> others: _____ Characteristic: <input type="checkbox"/> toxic <input type="checkbox"/> caustic <input type="checkbox"/> corrosiveness <input type="checkbox"/> abrasiv <input type="checkbox"/> foaming <input type="checkbox"/> others: _____
Valve	Nominal size: <input type="checkbox"/> DN 25 <input type="checkbox"/> DN 50 <input type="checkbox"/> DN 80 <input type="checkbox"/> DN 100
Option	Body + Plug: <input type="checkbox"/> haste alloy C4 <input type="checkbox"/> titanium <input type="checkbox"/> others: _____ others: <input type="checkbox"/> heating jacket <input type="checkbox"/> others: _____
Add-on Components	Bottle connection: <input type="checkbox"/> Free run out <input type="checkbox"/> Duran GL45 <input type="checkbox"/> flange connection <input type="checkbox"/> Duran GL32 <input type="checkbox"/> bajonet connection <input type="checkbox"/> others: _____ Attachment: <input type="checkbox"/> protection case <input type="checkbox"/> others: _____
Accessories	Schutzkasten: <input type="checkbox"/> Standard <input type="checkbox"/> 1" venting <input type="checkbox"/> others: _____ <input type="checkbox"/> support (not for bajonet locking) Operatin: <input type="checkbox"/> Star-grip <input type="checkbox"/> dead mans control Sampling container <input type="checkbox"/> Rounded side bottle <input type="checkbox"/> sample bottle DIN 4796 GL45 Duran clear glass <input type="checkbox"/> will be supplied by customer <input type="checkbox"/> others: _____ Others: _____ _____ _____

Table 2 - Check list

For your special requirements, please contact our technical department.

Pfeiffer Chemie-Armaturenbau GmbH

Hooghe Weg 41 • 47906 Kempen

Telefon: ++49(0)2152 / 2005-0 • Telefax: ++49(0)2152 / 1580

E-Mail: vertrieb@pfeiffer-armaturen.com • Internet: www.pfeiffer-armaturen.com

Specifications are subject to change without notice