

# Operating, assembly and maintenance instructions for continuous sampling valve Series 27k



Fig. 1 - Sampling valve series 27k

Violations are an offence and liable to claims for damages. We reserve all rights for the exercise of industrial property rights.



The equipment may only be dismantled and disassembled by skilled staff, who are familiar with the assembly, start-up, and the operation of this product.

Skilled staff in the sense of these repair and assembly instructions, are persons who, as a result of their training, knowledge, and experience, also their knowledge of the relevant standards, are able to judge the tasks assigned to them, and are able to recognise possible dangers.

## 1. Design, operation and dimensions

Design, operation and dimensions, also all further technical details can be found in the **Data sheet** < TB 27i\_EN > for sampling valve series 27i / 27k

## 0. Introduction

These instructions are intended to support the user in the assembly and repair of sampling valves of the series 27k.

Technical details, as a result further development of the valves mentioned in these instructions, are subject to modification. The text and illustrations do not necessarily display the scope of supply, or an eventual order of spare parts. Drawings and graphics are not to scale. Customer related designs, which are not in accordance with our standard offer, are not shown.

The transfer of these instructions to third parties is only allowed with the written approval of Pfeiffer Chemie-Armaturenbau GmbH. All documents are protected according to the laws of the German Copyright Act.

The transmission and/or duplication of documents, even in abstracts, also the exploitation and communication of their content is not permitted, unless expressly granted.

## 2. Installation, start-up and maintenance

Guidelines for the installation, start-up and maintenance can be found in the respective operating instructions for sampling valves.

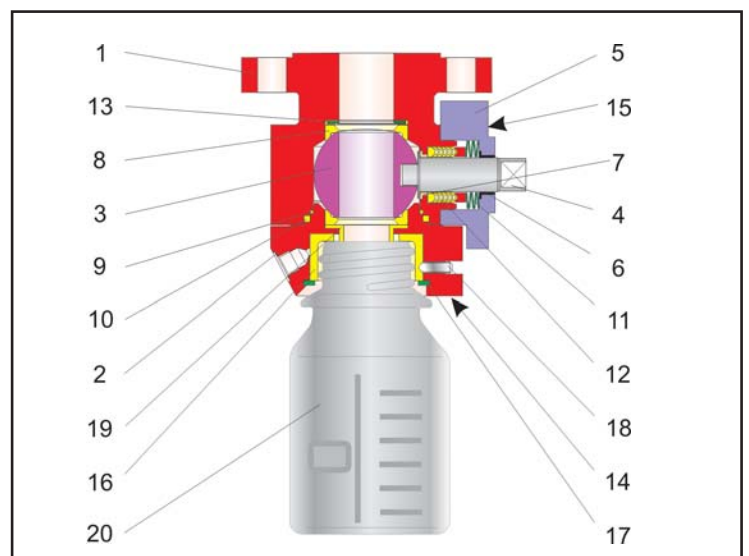

Fig. 2 - Sectional view of sampling valve Series 27k => Parts list, see table 1 on page 2

# Sampling valve Series 27k

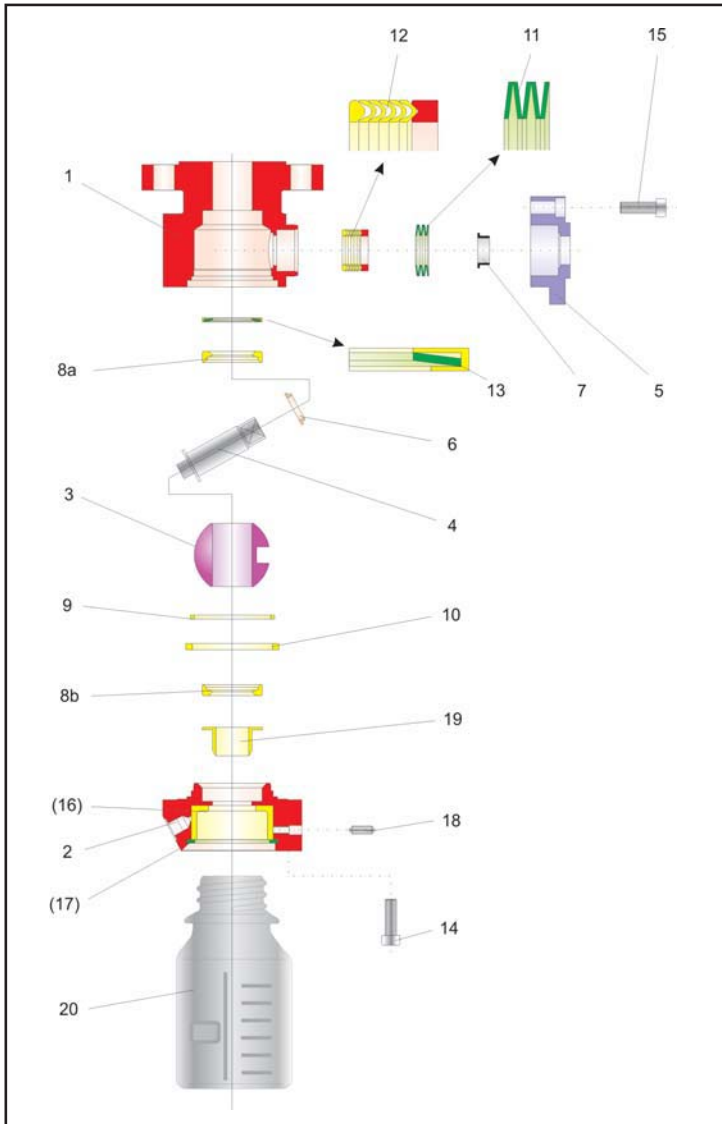

Fig. 3 - Explosion drawing of the sampling valve series 27k

Pos.	Qty.	Description	Material
1	1	Main body	1.4571
2	1	Bonnet	1.4571
3	1	Ball	1.4571
4	1	Control shaft	1.4571
5	1	Stuffing box	1.4571
6	1	Bearing bush	PTFE with 25% glass
7	1	Bearing bush	PTFE with 25% carbon
8	1	Sealing ring set	TFM
9	1	Ring	PTFE
10	1	Ring	PTFE
11	1	Spring washer set	1.8159 - Deltatone coated
12	1	V-ring packing	1.4305 / PTFE
13	1	Spring washer	1.4310
14	4	Screw	A2-70
15	4	Screw	A2-70
16	1	Insert	PTFE
17	1	Retainer ring	1.4310
18	1	Setting screw	A2-70
19	1	drip insert bush	PTFE
20	1	Sampling bottle	Glass

Table 1 - Parts list

## 3. Assembly of the sampling valve

### 3.1 Preparation for assembly

Before assembling the sampling valve, clean all parts thoroughly, and lay them on a soft padded surface ( rubber mat etc.). Take into consideration, that parts made of plastic are always soft and sensitive, and especially the sealing surfaces must not be damaged.



**Attention:** To avoid cold corrosion of the screws in the bodies, the manufacturer has used a high performance grease (e.g. Gleitmo 805. from Fuchs). This grease however, may not be applied to valves, which are used in an oxygen environment, an appropriate lubrication must be used.



**Note:** The position and arrangement of the individual parts shown in the explosion drawing (fig. 3) must be strictly adhered to when assembling the valve.

### 3.2 Assembly of the main body

The assembly starts with the main body ( 1 ). Insert the lined spring washer ( 13 ) into the main body ( 1 ). The assembly position can be taken from the drawing ( Fig. 3 ).

The sealing ring ( 8a ) is pressed onto the spring washer.

With a light rotating movement, press the bearing sleeve ( 6 ) onto the stem ( 4 ).

Guide the stem ( 4 ) together with the bearing sleeve ( 6 ) through the intended stem opening in the inside of the main body ( 1 ).



The sealing surface of the stem ( 4 ) must not be damaged. It is also necessary to ensure, that when inserting the sealing sleeve ( 6 ) together with the stem ( 4 ) in the opening of the body, ( 1 ) that edging is avoided.

The stem ( 4 ) must now be rotated, so that squared end is vertical to the working surface. Now the ball ( 3 ) can be carefully inserted.

Place the body sealing rings ( 9 and 10 ) in the turned bore of the body ( 1 ).

The bonnet ( 2 ) together with the insert ( 16 ) and the retainer ring ( 17 ) are pre-assembled, and fixed in position with the setting screw ( 18 ).

Place the insert sleeve ( 19 ) and the sealing ring ( 8b ) in the bonnet ( 2 ).

The pre-assembled bonnet ( 2 ) is placed onto the body ( 1 ) and carefully pressed together.

Turn and position the bonnet ( 2 ) so that connecting bores of both bodies ( 1 und 2 ) are aligned to each other.

Apply grease to the screws ( 14 ) Now, screw the body ( 1 ) and the bonnet together ( 2 ), evenly and in an alternating pattern.

### 3.3 Final assembly of the sampling valve

With a light rotating movement, push the V-ring packing (12 ) over the control shaft ( 4 ) and place in the packing chamber of the main body ( 1 ).

Refer to the explosion drawing ( Bild 3 ) for exact positioning of the V-rings.

The spring washers ( 11 ) are placed on the packing. The positioning of the spring washers can also be taken from the explosion drawing ( Bild 3 ).

The bearing sleeve ( 7 ) is pressed into the stuffing box flange ( 5 ). Following this, place the stuffing box flange ( 5 ) over the control shaft, and onto the body. With the greased screws ( 15 ) align and tighten the screws evenly in alternating pattern.

**Note:** Before testing for leak tightness, the valve should be operated once or twice, to enable the ball to sit correctly in the sealing rings, therefore ensuring a good sealing function.



The sampling container e.g. the sampling bottle ( 20 ) is screwed onto the sampling valve.

**The assembly of the sampling valve is now completed.**

## 4. Trouble shooting

Action to be taken in the event of malfunction is described in the operating instructions for the sampling valve. You can also contact Pfeiffer Chemie-Armaturenbau GmbH directly if you require help.

## 5. Repairing the sampling valve

### 5.1 Replacing the V-ring packing

If leakage is located at the stuffing box, the PTFE-rings of the V-ring packing ( 12 ) may be defect.

It is therefore recommended to check the condition of the packing.

To dismantle the V-ring packing, proceed in reverse order to the assembly as described in Section 3

Proceed to check the PTFE-rings of the V-ring packing as with all other plastic part for damage, and if necessary replace all defect parts.

### 5.2 Replacing the sealing seat and the ball

If the ball valve does not shut-off tightly and leaks, the sealing rings ( 8a and 8b ) and the ball ( 3 ) may be defect. It is recommended to check these parts.

To dismantle the sealing rings and the ball, proceed in reverse order to the assembly instructions described in Section 3. Check the sealing rings and the ball, as with all other plastic parts for damage, and if necessary replace these parts.

### 5.3 Other repairs

We recommend large repairs to be carried out in our works, by our skilled staff at Pfeiffer.

## 6. Operating the sample valve

### 6.1 Important general instructions



According to the media being used, it may be necessary to clean the sampling chamber and the through bore after a sample has been taken. The operator must decide if and when this is necessary.

- It is absolutely important, that before taking a sample, the sampling container (glass bottle etc.) is adapted to the temperature of media being taken!
- Safety precautions need to be taken when the media temperature exceeds 60° as a risk of scalding is possible.
- When taking samples, the general accident prevention regulations must be complied with at all times!

### 6.2 Sampling valve with „dead mans control



- Screw on the sample bottle by hand as tightly as possible.
- Turn the hand-lever 90° until the bore is in the media flow.
- Hold the lever in this position until the required amount of media has been collected.
- Turn back the hand-lever.
- 
 Do not release the hand-lever abruptly, when collecting the media, or at the end of sampling, as the automatic device will be activated and sampling will stop automatically.
- Unscrew the sampling bottle, and if necessary seal with a lid.

# Sampling valve Series 27k

## 6.3 Sampling valve with hand-lever and protective case



- Open protective case.
- Screw on the sample bottle by hand as tightly as possible.
- Close protective case.
- Turn the hand-lever 90° until the bore is in the media flow.
- Hold in this position until the required amount has been collected.
- Turn back the hand-lever.



Do not release the hand-lever abruptly while collecting, or at the end of sampling, as the automatic safety device will be activated, and the sampling will stop automatically.

- Open the protective case and remove the sampling bottle, and if necessary seal bottle with a lid.
- Close the protective case.

## 6.4 Sampling valve with „dead mans control“ and protective case and support

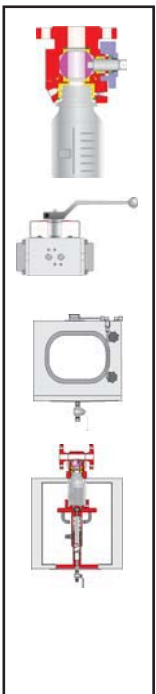

- Open protective case.
- Pull down the support on the handlever.
- Place the sampling bottle into the PTFE- seat of the support.
- Guide the support upwards and close protective case.
- Turn the hand-lever 90° until the bore is in the media flow.
- Hold the hand-lever in this position until the required amount has been collected.
- Turn back th hand-lever.



Do not release the hand-lever abruptly when collecting samplin media, or at the end of sampling, as the automatic safety device will be activated and the sampling will stop automatically.

- Open the protective case, guide the support downwards and remove the sample bottle, if necessary seal bottle with a lid.
- Close protective case.

## 6.5 Sampling valve with automatic 90° rotary actuator and protective case

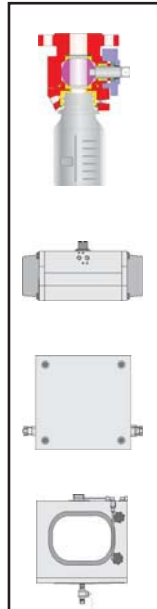

### 6.5.1 general automated sampling

- Open protective case.
- Screw on sample bottle by hand as tightly as possible.
- Close protective case.
- Open the air supply valve at the automation unit.
- **Attention:** Before operating, refer to the respective operating instructions for the automated unit, which can be found in **Section 7**
- Close the air supply valve at the automation unit.
- Open the protective case, remove the sample bottle, if necessary seal bottle with a lid.
- Close the protective case.

### 6.5.2 automated sampling with back pressure indication

- Operating this type of sampling is identical to the operating instructions in **Section 6.5.1**
- In addition to the above mentioned version, the following function is included:
  - The automation switches off automatically and no further sample can be taken when the sample level in the glass reaches the back pressure tube.



When attaching the bottle, avoid at all times bending the back pressure tube!

### 6.5.3 automatic sampling with pneumatic barrier

- Operating this type of sampling is identical to the operating instructions in **Section 6.5.1**
- In addition to the above mentioned version, the following function is included:
  - The automation switches off automatically, and no further sample can be taken when the protective case is opened during sampling procedure.

## 6.6 Sampling valve with automated 90° rotary actuator and protective case with support

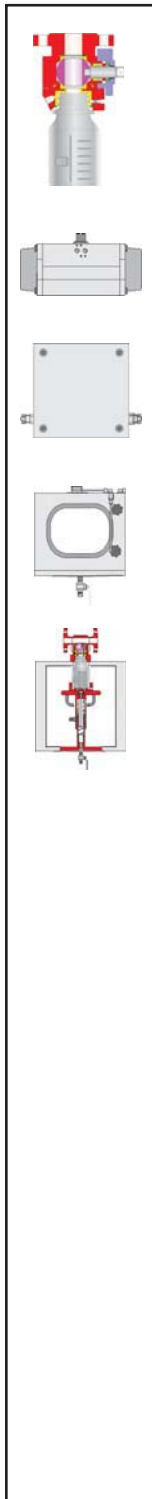

### 6.6.1 general automatic sampling

- Open protective case.
- Pull down the support on the handlever.
- Place the sample bottle in the PTFE-seat of the support.
- Guide the support upwards.
- Close the protective case.
- Open the air supply valve at the automation unit.
- **Attention:** Operating this type of sampling is identical to the operating instructions in **Section 7**. (Operating the automation unit)
- Close the air supply valve at the automation unit.
- Open the protective case, guide the support downwards, remove sample bottle, and if necessary seal the bottle with a lid.
- Close protective case.

### 6.6.2 automatic sampling with back pressure indication

- Operating this type of sampling is identical to the operating instructions in **Section 6.6.1**
- In addition to the above mentioned version, the following function is included:

- The automation switches off automatically, and no further sample can be taken, when the sample level in the bottle reaches the back pressure tube!
-  When attaching the bottle, avoid at all times bending the back pressure tube!

### 6.6.3 automated sampling with pneumatic barrier

- Operation for this type of sampling is identical to the operating instruction described in **Section 6.6.1**
- In addition to the above mentioned version, the following function is included:
- The automation switches off automatically and no further sample can be taken when the protective case is opened during sampling procedure.

## 7. Operating the automation units

### 7.1 Automation with „ON / OFF“ - Switch



**Note:** The timing for filling the actuator with air or venting, are pre-set timings, which were set before leaving our works. Any alterations to these settings may only be made after first consulting Pfeiffer Chemie-Armaturenbau GmbH!

- Press the start button.  
Continue pressing the button until the required amount of media has been collected in the bottle.



If the button is released during of at the end of sampling, the dead mans control is activated and the sampling is switched off automatically.

### 7.2 Automation with counter



**Note:** The pulse and interval times between actuation cycles, and the timing for filling or venting the actuator with air, are pre-set timings, which were set before leaving our works. Any alterations to these settings, may only be made after first consulting Pfeiffer Chemie-Armaturenbau GmbH!

- Set the number of actuating cycles at the counter.



**Attention:** The selected number of actuating cycles must correspond to the volume of sample bottle.

- Press the start button.  
The pre-selected number of actuating cycles to take samples are performed.
- The sampling finishes automatically after the selected number of actuating cycles have been completed.



**Attention!** In the case of an operation fault, press the emergency button immediately.

# Sampling valve Series 27k

## 7.3 Automation with counter and timer switch

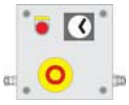

**Note:** The pulse and interval times between actuation cycles, and the timing for filling the actuator with air or venting, are pre-set timings, which were set before leaving our works. Any alterations to these settings may only be made after first consulting Pfeiffer Chemie-Armaturen-bau GmbH!

- The required interval between each actuation cycle, can be set at the timer switch.

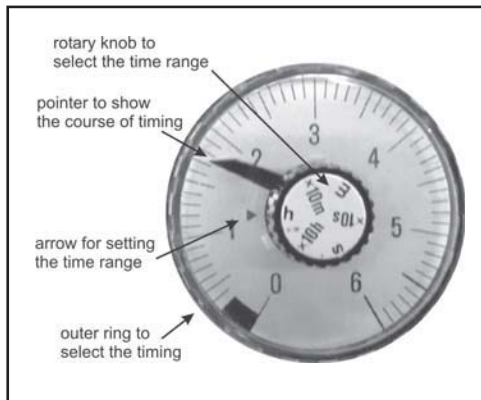

Fig. 4 - Samsomatic - Time switch 3970

- Select time range  
The switch-over range is selected with the rotary knob located in the middle of the timer, by setting the dial arrow to the required range.

Selection	Time range
s	0,3 to 6 Seconds
x10s	3 to 60 seconds
m	0,3 to 6 minutes
x10m	3 to 60 minutes
h	0,3 to 6 hours
x10h	3 to 60 hours

Table 2 - Time ranges

- Determine which timing you require. The required cycle time can be set by turning the outer ring. A pointer indicates the cycle time.
- Set the number of actuation cycles at the counter.



**Attention:** The selected number of actuating cycles must correspond to the volume of the sample bottle.

- Press the start button. The pre-selected number of actuating cycles to take samples, together with the pre-selected intervals are performed.

- The sampling finishes automatically after the selected number of actuating cycles have been completed.



**Attention!** In the case of an operation fault, press the emergency button.

### 8. Circuit diagram

Circuit diagram for the automation unit  
Should you have any queries, please contact Pfeiffer Chemie-Armaturenbau GmbH

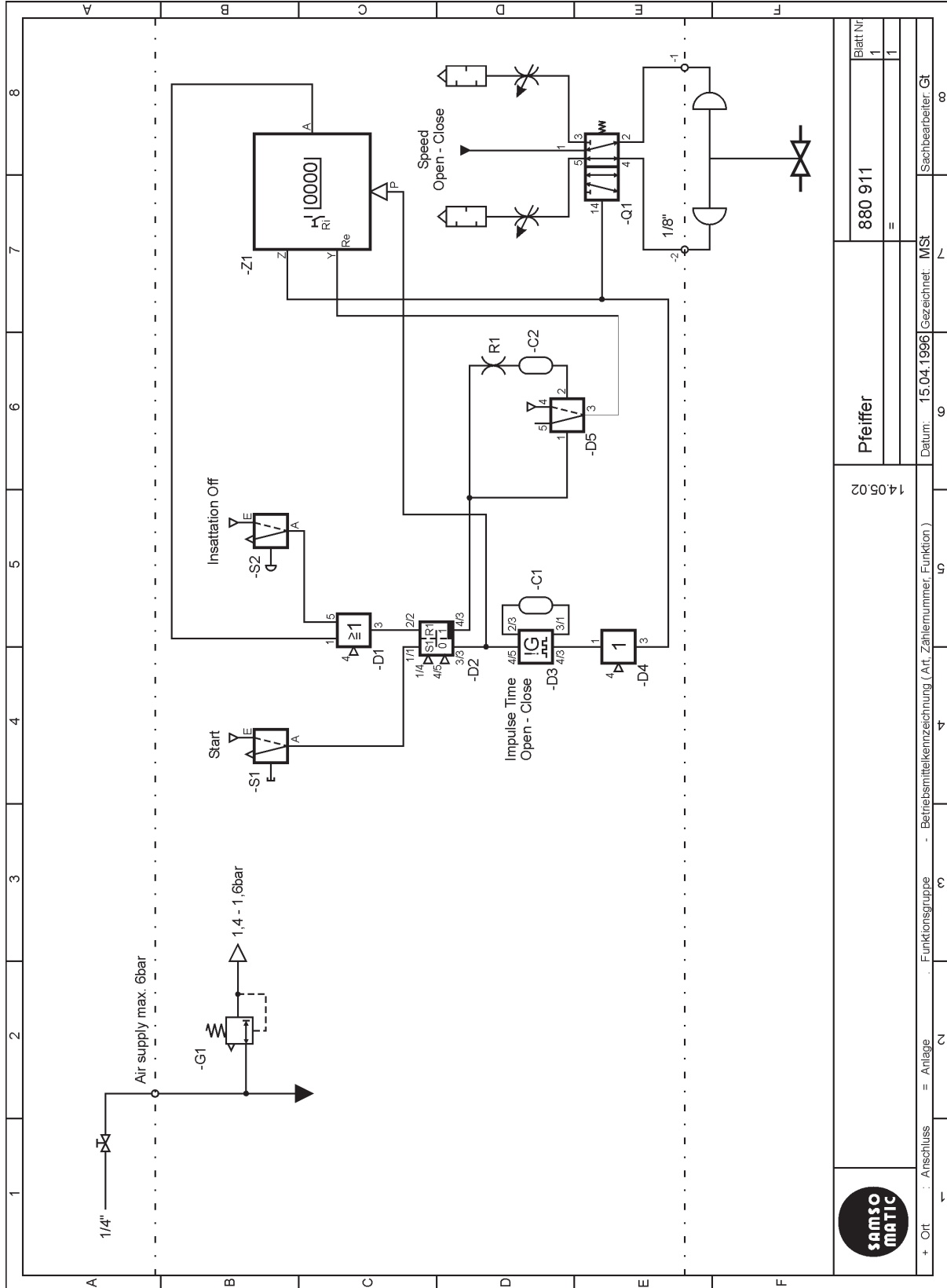

Fig. 5 - Circuit diagram

## 9. Customer inquiries

Details as per check list for repairs and inquiries.

Check list for repairs and inquiries for the sampling valve 27k	
<b>General</b>	Commission number: (embossed on the type plate) _____ Customer: _____ Telephone: _____ Fax: _____
<b>Media</b>	Media: _____ Temperature: _____ °C      op pressure: _____ bar Viscosity: <input type="checkbox"/> like water <input type="checkbox"/> like honey <input type="checkbox"/> like oil <input type="checkbox"/> others: _____ Characteristic: <input type="checkbox"/> toxic <input type="checkbox"/> caustic <input type="checkbox"/> corrosiveness <input type="checkbox"/> abrasiv <input type="checkbox"/> foaming <input type="checkbox"/> others: _____
<b>Valve</b>	Nominal size: <input type="checkbox"/> DN 25 <input type="checkbox"/> DN 50 <input type="checkbox"/> DN 80
<b>Option</b>	Body: <input type="checkbox"/> hastet alloy C4 <input type="checkbox"/> titanium <input type="checkbox"/> others: _____ Ball: <input type="checkbox"/> zirkonium oxid <input type="checkbox"/> titanium 0,2% Pd <input type="checkbox"/> sonstiges: _____ others: <input type="checkbox"/> spring washer nickel plated <input type="checkbox"/> O-ring Viton / FEP lined <input type="checkbox"/> heating case <input type="checkbox"/> others: _____
<b>Add-on Components</b>	Bottle-connection: <input type="checkbox"/> Duran GL45 <input type="checkbox"/> Duran GL32 <input type="checkbox"/> flange connection <input type="checkbox"/> others: _____ <input type="checkbox"/> bajonet connection Attachment: <input type="checkbox"/> protection case <input type="checkbox"/> others: _____
<b>Accessories</b>	Protection case: <input type="checkbox"/> Standard <input type="checkbox"/> 1" venting <input type="checkbox"/> others: _____ <input type="checkbox"/> support (not for bajonet locking) Automation: <input type="checkbox"/> with counter <input type="checkbox"/> ON / OFF <input type="checkbox"/> timer switch Actuator: <input type="checkbox"/> multi-turn actuator (DAP 100 - 90°) <input type="checkbox"/> dead mans control <input type="checkbox"/> actuator      manufacturer: _____      Type: _____ Sampling container: <input type="checkbox"/> sampling bottle DIN 4796 GL45 Duran clear glass <input type="checkbox"/> will be supplied by customer <input type="checkbox"/> others: _____ Others: _____ _____ _____

Table 3 - Check list

**For your special requirements, please contact our technical sales department.**

## Pfeiffer Chemie-Armaturenbau GmbH

Hooghe Weg 41 • 47906 Kempen  
 Telephone: 0049 (0)2152 / 2005-0 • Fax: 0049 (0)2152 / 1580  
 E-Mail: [vertrieb@pfeiffer-armaturen.com](mailto:vertrieb@pfeiffer-armaturen.com) • Internet: [www.pfeiffer-armaturen.com](http://www.pfeiffer-armaturen.com)

Specifications are subject to change without notice