

Operating, assembly and maintenance instructions for continuous sampling valve Series 27m



Fig. 1 - Sampling valve series 27m



This equipment may only be dismantled and disassembled by skilled staff, who are familiar with the assembly, the start-up and the operation of this product.

Skilled staff in the sense of these repair and assembly instructions, are persons who, as a result of their training, knowledge, and experience, also their knowledge of the relevant standards, are able to judge the tasks assigned to them and are able to recognise possible dangers.

1. Design, operation and dimensions

Design, operation and dimensions, as well as all further technical details may be found in the **Data sheet < TB 271_EN >** for sampling valve Series 271 / 27m.

2. Installation, start-up and maintenance

Guidelines for the installation, start-up and maintenance can be found in the respective operating instructions for sampling valves.

0. Introduction

These instructions are intended to support the user in the assembly and repair of sampling valves of series 27m

Technical details, as a result of further development of the valves mentioned in these instructions are subject to modification.

The text and illustrations do not necessarily display the scope of supply, or an eventual order of spare parts. Drawings and graphics are not to scale. Customer related designs, which are not in accordance with our standard offer, are not shown. The transfer of these instructions to third parties is only allowed with the written approval of Pfeiffer Chemie-Armaturenbau GmbH.

All documents are protected according to the laws of the German Copyright Act.

The transmission and/or duplication of documents, even in abstracts, also the exploitation and communication of their content is not permitted, unless expressly granted.

Violations are an offence and liable to claims for damages. We reserve all rights for the exercise of industrial property rights.

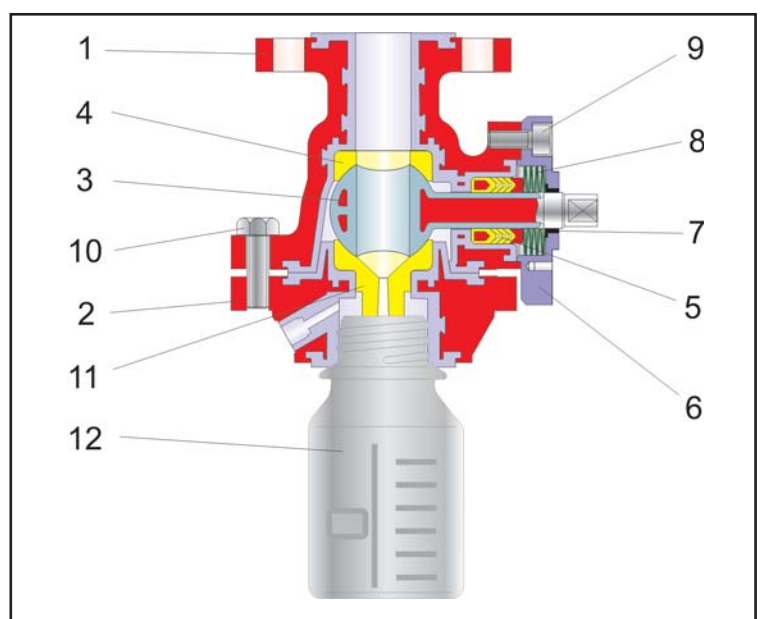

Fig 2 - Sectional view of sampling valve series 27m => Parts list, see table 1 on page 2

Sampling valve Series 27m

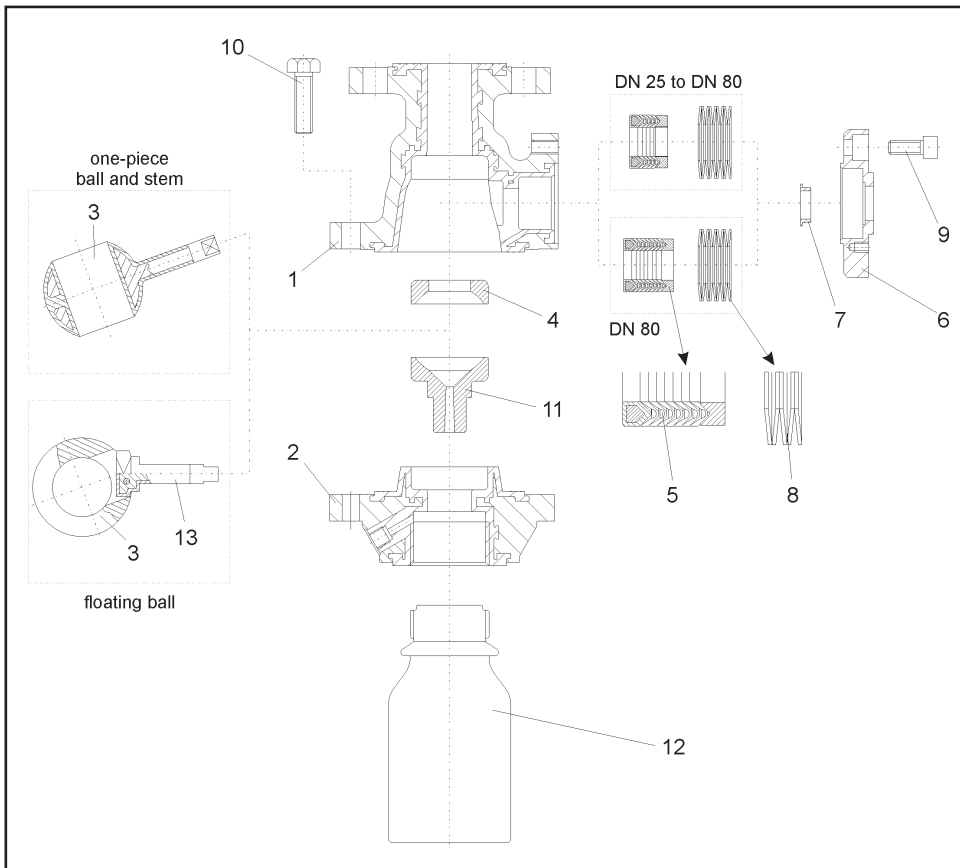

Fig. 3 - Explosion drawing of the sampling valve Series 27m

Pos.	Description	Material
1	Main body	GGG 40.3 / PFA
2	Body	C22.8 / PFA
3	Ball	1.4313 / PFA
4	Sealing ring	PTFE
5	V-ring packing	1.4305 / PTFE
6	Stuffing box flange	1.4305
7	Bearing bush	PTFE with carbon
8	Spring washer set	1.8159 / Delta tone
9	Screw	A2-70
10	Screw	A2-70
11	Sealing seat	PTFE
12	Sampling bottle	Glass
13	Control shaft	1.4313 / PFA

Table 1 - Parts list

3. Assembly of the sampling valve

3.1 Preparation for assembly

Before assembling the sampling valve, first clean all parts thoroughly, and lay them on a soft padded surface (rubber mat ect.) Take into consideration, that parts made of plastic are generally soft and sensitive, in particular the sealing surfaces must be handled with care and not be damaged.



Attention: To avoid cold corrosion of the screws in the bodies, the manufacturer has used a high performance grease (e.g. Gleitmo 805. from. Fuchs).

This grease however, may not be applied to valves, which are used in an oxygen environment. Valves which must be free of grease, especially for use in oxygen, an appropriate lubrication must be used.



Note: The position and arrangement of the individual parts shown in the explosion drawing (Fig. 3) must be observed when assembling the valve.

3.2 Initial assembly of the ball valve

3.2.1 Initial assembly of the single ball

Place the body (1) with the piping flange facing downwards on a soft surface. The sealing

ring (4) is placed in the main body. Guide the ball (3) with the control shaft slightly inclined into the packing chamber.



Note: When inserting the ball, the bore of the ball, and the bore of the main body must be facing in the same direction.

further assembly instructions are described under item: „Final assembly of the ball valve“.

3.2.2 Initial assembly of the floating ball

Place the body (1) with the piping flange facing downwards on a soft surface. The sealing ring (4) is placed in the main body.

Guide the control shaft (13) slightly inclined into packing chamber. Then insert and position the ball (3) so that the slot in the ball fits onto the two flats of the control shaft (13).



Note: When inserting the ball, the bore in the ball must be facing diagonally to the bore of the main body.

Further assembly instructions are under item: „Final assembly of the ball valve“.

3.3 Final assembly of the ball valve

Place the sealing ring (11) in the body (2). Now carefully press the pre-assembled body (2) onto the main body (1). Turn and position the body (2) so that the bores of both

body parts are aligned to each other (1 and 2).
Apply grease to the screws, (10) align, and hand tighten.
For further assembly, clamp the main body (1) in a vice.

Using the ground ring of the V-ring packing, (5) centre the shaft of the ball (3 e.g. 13) in the packing chamber, the ring is then pushed down to sit firmly in the body recess .



Note: Due to the effort required to push the ground ring in position, it may be necessary for this purpose to use an appropriate tool.

Also with this tool each of the V-rings can be inserted separately into the packing of the body.
Now the screws for connecting the middle parts can be tightened.



Note: The tightening sequence, and the tightening torques are shown in fig. 4 and table 2 for the respective nominal diameters.

The spring washer set (8) is placed on the V-ring packing.
For the assembly of the spring washers, refer to the explosion drawing (Fig. 3)
Press the bearing bush (7) into the stuffing box flange (6).
Afterwards, place the stuffing box flange (6) over the control shaft, onto the body, and after applying grease to the screws, (9) align and tighten evenly and in alternating pattern.



Note: Before testing for leakage tightness, the valve should be operated once or twice, to enable the ball to sit correctly in the sealing rings, therefore ensuring a good sealing function.

Assembly of the sampling valve is now completed.

3.4 Tightening torques for connecting both bodies

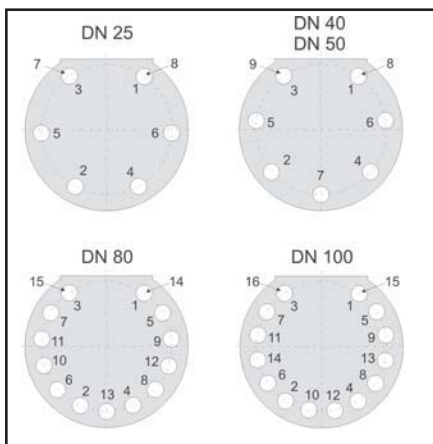

Fig. 4 - Sequence for screw connections

When connecting both body halves, please observe the tightening sequence and the tightening torques for the respective nominal diameter.

Nominal diameter	Connection	Torque
DN 25	1 to 6	25 Nm
	7 to 8	30 Nm
DN 50	1 to 7	35 Nm
	8 and 9	40 Nm

Table 2 - Tightening torque

4. Trouble shooting

Action to be taken in the case of malfunction is described in the operating instructions for the sampling valve. You can also contact Pfeiffer Chemie-Armaturenbau GmbH directly if you require help.

5. Repairing the sampling valve

5.1 Replacing the V-ring packing

If leakage is located at the stuffing box, the PTFE-rings of the V-ring packing (5) may be defect. It is therefore recommended to check the condition of the packing.
To dismantle the packing, proceed in reverse order to the assembly instructions as described in Section 3.
Proceed to check the PTFE-rings of the V-ring packing as with all other plastic parts for damage, and if necessary replace these parts.

5.2 Replacing the sealing seat and the ball

If the ball valve does not shut-off tightly and shows signs of leakage, the sealing rings (4 and 13) and the ball (3) may be defect. It is therefore recommended to check these parts.
To dismantle the sealing rings and the ball, proceed in reverse order to the assembly instructions as described in Section 3. As with all other plastic parts, proceed to check the sealing rings and the ball for damage, and if necessary replace these parts.

5.3 Other repairs

We recommend large repairs to be carried out in our works, by our skilled staff at Pfeiffer.

Sampling valve Series 27m

6. Operating the sample valve

6.1 Important general instructions

Depending on the media being used, it may be necessary to clean the chamber and the through bore after a sample has been taken. The operator must decide if and when this is necessary.

- It is essential to ensure, that before taking a sample, the sampling container (glass bottle etc.) is first adapted to the temperature of media being taken!
- Safety precautions need to be taken when the media temperature exceeds 60° as a risk of scalding is possible.
- When taking samples, the general accident prevention regulations must be complied with at all times!

6.2 Sampling valve with „dead mans control“



- Screw on the sample bottle by hand as tightly as possible.
- Turn the hand-lever 90° until the bore is in the media flow.
- Hold the lever in this position until the required amount of media has been collected.
- Turn back the hand-lever.



Do not release the hand-lever abruptly when collecting, or at the end of sampling, as the automatic device will be activated and sampling will stop automatically.

- Unscrew the sampling bottle, and if necessary seal with a lid.

6.3 Sampling valve with „dead mans control“ and protective case



- Open protective case.
- Screw on the sample bottle by hand as tightly as possible.
- Close protective case.
- Turn hand-lever 90° until the bore is in the media flow.
- Hold in this position until the required amount has been collected.
- Turn back the hand-lever.



Do not release the hand-lever abruptly while collecting the media, or at the end of sampling, as the automatic safety device will be activated, and the sampling will stop automatically.

- Open the protective case, and remove the sampling bottle, if necessary seal bottle with a lid.
- Close protective case.

6.4 Sampling valve with „dead mans control“ and Protective case and support



- Open protective case.
- Pull down the support on the handlever.
- Place the sampling bottle into the PTFE seat.
- Guide the support upwards and close protective case.
- Turn the hand-lever 90° until the bore is in the media flow.
- Hold the hand-lever in this position until the required amount has been collected.
- Turn back the hand-lever.



Do not release the hand-lever when collecting or at the end of sampling, as the automatic device will be activated, and sampling will stop automatically.

- Open protective case, guide the support downwards, if necessary seal bottle with a lid.
- Close protective case.

6.5 Sampling valve with automatic 90° rotary 90° actuator and protective case

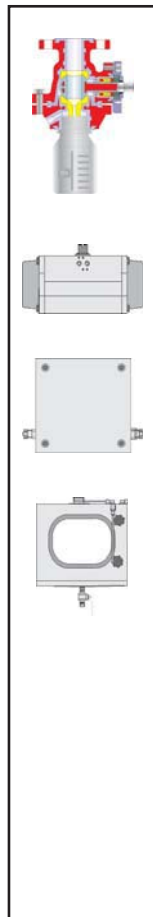

6.5.1 general automated sampling

- Open protective case.
- Screw on sample bottle by hand as tightly as possible.
- Close protective case.
- Open the air supply valve at the automation unit.
- **Attention:** Before operating, refer to the respective operating instructions for the automation unit, which can be found in **Section 7**.
- Close the air supply at the automation unit.
- Open the protective case, remove the sample bottle, if necessary seal bottle with a lid.
- Close the protective case.

6.5.2 automated sampling with back pressure indication

- Operating this type of sampling is identical to the operating instructions in **Section 6.5.1**
- In addition to the above mentioned version, the following function is included:
 - The automation switches off automatically and no further sample can be taken when the sample level in the glass reaches the back pressure tube.



When attaching the bottle, avoid at all times bending the back pressure tube!

6.5.3 automatic sampling with pneumatic barrier

- Operating this type of sampling is identical to the operating instructions in **Section 6.5.1**
- In addition to the above mentioned version, the following function is included:
 - The automation switches off automatically and no further sample can be taken when the protective case is opened during sampling procedure.

6.6.3 automated sampling with pneumatic barrier

- Operation for this type of sampling is identical to the operating instructions described in **Section 6.6.1**
- In addition to the above mentioned version, the following function is included:
 - The automation switches off automatically and no further sample can be taken when the protective case is opened during sampling procedure.

6.6 Sampling valve with automated 90° rotary actuator and protective case with support

6.6.1 general automatic sampling

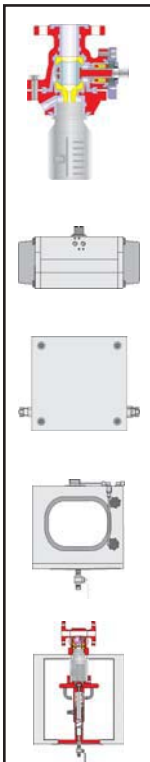

- Open protective case.
- Pull down the support on the handlever.
- Place the sample bottle in the PTFE-seat.
- Guide the support upwards.
- Close the protective case.
- Open the air supply valve at automation unit.
- **Attention:** Before operating, refer to the operating instructions in **Section 7** (operating the automation unit).
- Close the air supply valve at the automation unit.
- Open the protective case, guide the support downwards, remove sample bottle, and if necessary seal the bottle with a lid.
- Close protective case.

6.6.2 automatic sampling with back pressure indication

- Operating this type of sampling is identical to the operating instructions in **Section 6.6.1**
- In addition to above mentioned version, the following function is included:
 - The automation switches off automatically and no further sample can be taken, when the sample level in the bottle reaches the back pressure tube!



When attaching the bottle, avoid at all times bending the back pressure tube!

7. Operating the automation units

7.1 Automation with „ON / OFF“ - Switch



Note: The timing for filling the actuator with air or venting, are pre-set timings, which were set before leaving our factory. Any alterations to these settings may only be made after first consulting Pfeiffer Chemie-Armaturenbau GmbH!

- Press the start button. Continue pressing the button until the required amount of media has been collected in the bottle.

If the button is release during or at the end of sampling, the dead mans control is activated and the sampling is switched off automatically.

7.2 Automation with counter

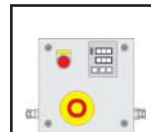

Note: The pulse and interval times between actuation cycles, and the timing for filling the actuator with air or venting, are pre-set timings, which were set before leaving our factory. Any alterations to these settings may only be made after first consulting Pfeiffer Chemie-Armaturenbau GmbH!

- Set the number of actuating cycles at the counter.



- **Attention:** The selected number of actuating cycles must correspond to the volume of sample bottle.
- Press the start button. The pre-selected number of actuating cycles to take samples are performed.
- The sampling finishes automatically after the selected number of actuating cycles has been completed.

Sampling valve Series 27m



Attention! In the case of an operation fault, press the emergency button immediately.

7.3 Automation with counter and timer switch



Note: The pulse and interval times between actuation cycles, and the timing for filling the actuator with air, or venting, are pre-set timings, which were set before leaving our works. Any alterations to these settings may only be made after first consulting Pfeiffer Chemie-Armaturen-bau GmbH!

- The required interval between each actuation cycle can be set at the timer switch.

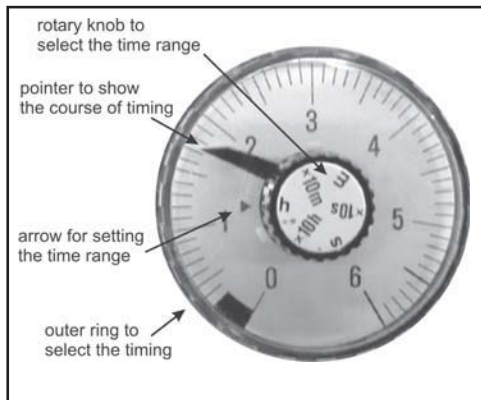

Fig. 4 - Samsomatic - Timer switch 3970

- Select time range
The switch-over range is selected with the rotary knob located in the middle of the timer. With the dial arrow the required range can be set.

Selection	Time range
s	0,3 to 6 seconds
x10s	3 to 60 seconds
m	0,3 to 6 minutes
x10m	3 to 60 minutes
h	0,3 to 6 hours
x10h	3 to 60 hours

Table 3 - Time range

- Determine which timing you require.
The required cycle time can be set by turning the outer ring. A pointer indicates the cycle time.
- Set the number of actuation cycles at the counter.



Attention: The selected number of actuating cycles must correspond to the volume of the sample bottle.

- Press the start button.
The pre-selected number of actuating cycles to take samples, together with the pre-selected intervals are performed.
- The sampling finishes automatically after the selected number of actuating cycles have been completed.



Attention! In the case of an operation fault, press the emergency button immediately.

8. Circuit diagram

Circuit diagram for the automation unit.

Should you have any questions, please contact Pfeiffer Chemie-Armaturenbau GmbH

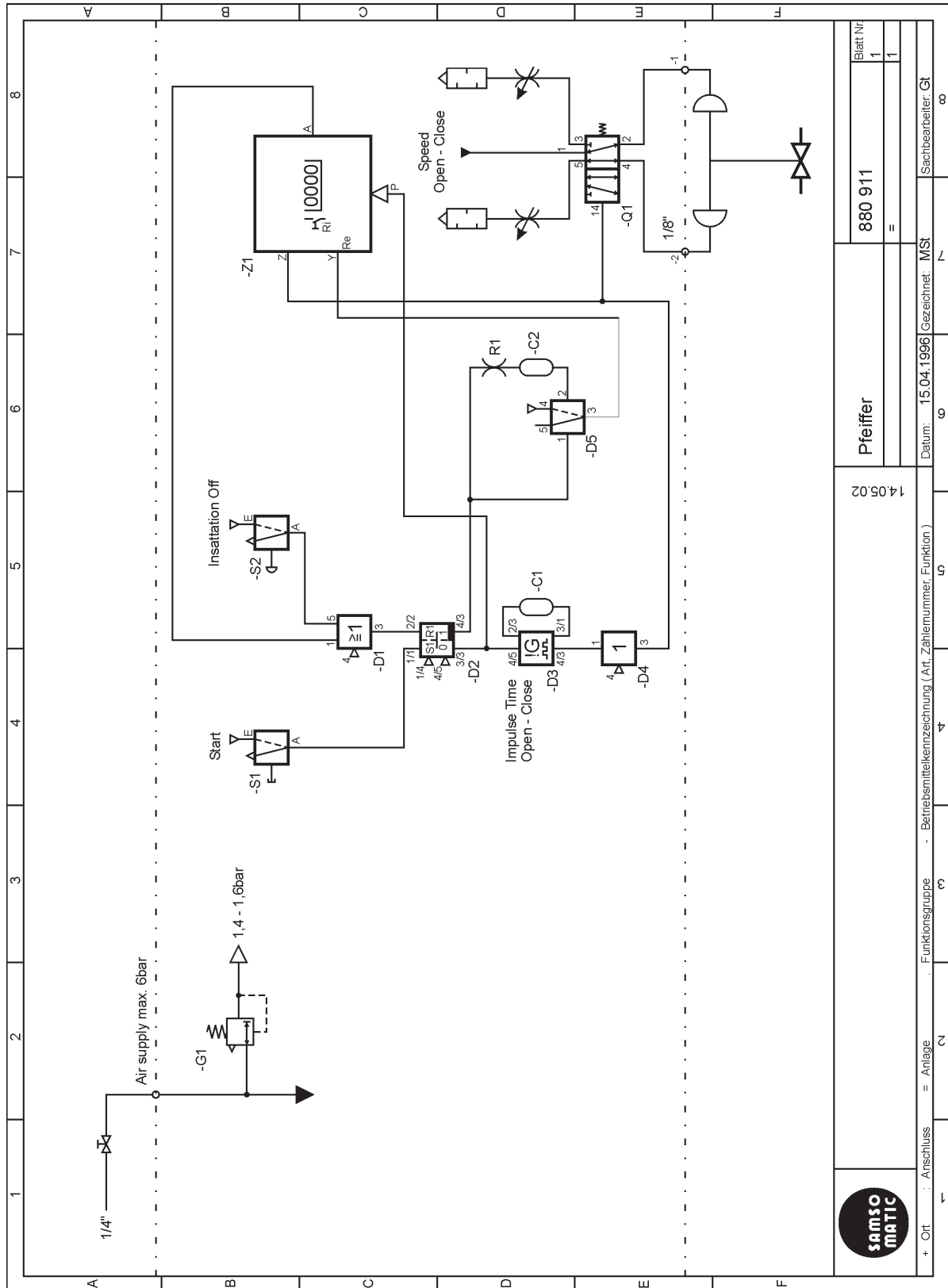

Fig. 5 - Circuit diagram

