

Maintenance

Globe Control Valve Series 1z



Fig. 1 – Series 1z Globe Valve with Samson Actuator

0. Introduction

These instructions are intended to assist the user on assembling and repairing Series 1z Control Valves.

Specifications are subject to change without notice. The text and drawings do **not necessarily** display the scope of supply or any ordering of spare parts. Drawings and graphics are not to scale.

Customer-specific designs not in accordance with our standard product range are not shown.

These instructions may only be passed on to third parties with written approval of Pfeiffer Chemie-Armaturenbau GmbH.

All documents are protected by German copyright laws.

The transmission and/or duplication of documents, even excerpts, as well as the use and communication of their content are not permitted unless expressly granted.

Offenders will be liable for payment of damages. All rights to exercise industrial property rights are reserved.



The equipment may only be dismantled and disassembled by skilled staff who are familiar with the assembly, start-up, and operation of this product.

In these maintenance and assembly instructions, the term skilled staff refers to individuals who are able to judge the responsibilities assigned to them as well as recognize potential hazards due to their specialized training, knowledge, and experience as well as their special knowledge of the relevant standards.

1. Design, operation, and dimensions

Design, operation, and dimensions as well as all further details and technical data can be found in **Data Sheet <TB 01z_EN>** for control valves.

2. Installation, start-up and maintenance

Instructions for the installation, start-up and maintenance are to be found in **Operating Instructions**

< **BA 01a-01_EN** > for pneumatic valves,

< **BA 01a-02_EN** > for manually operated valves.

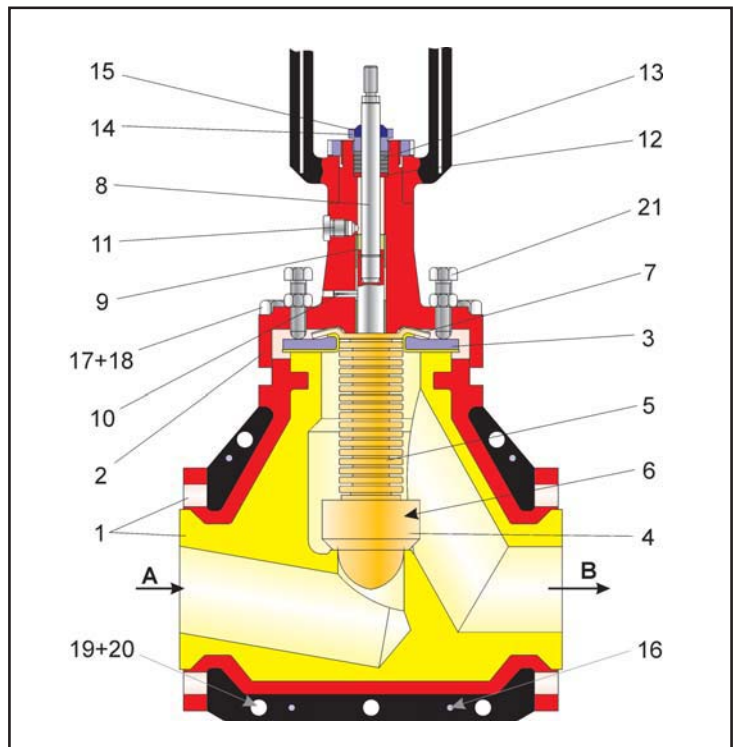

Fig. 2 - Cross-section through a Series 1z Control Valve => see Table 1 for list of parts

Globe Control Valve Series 1a

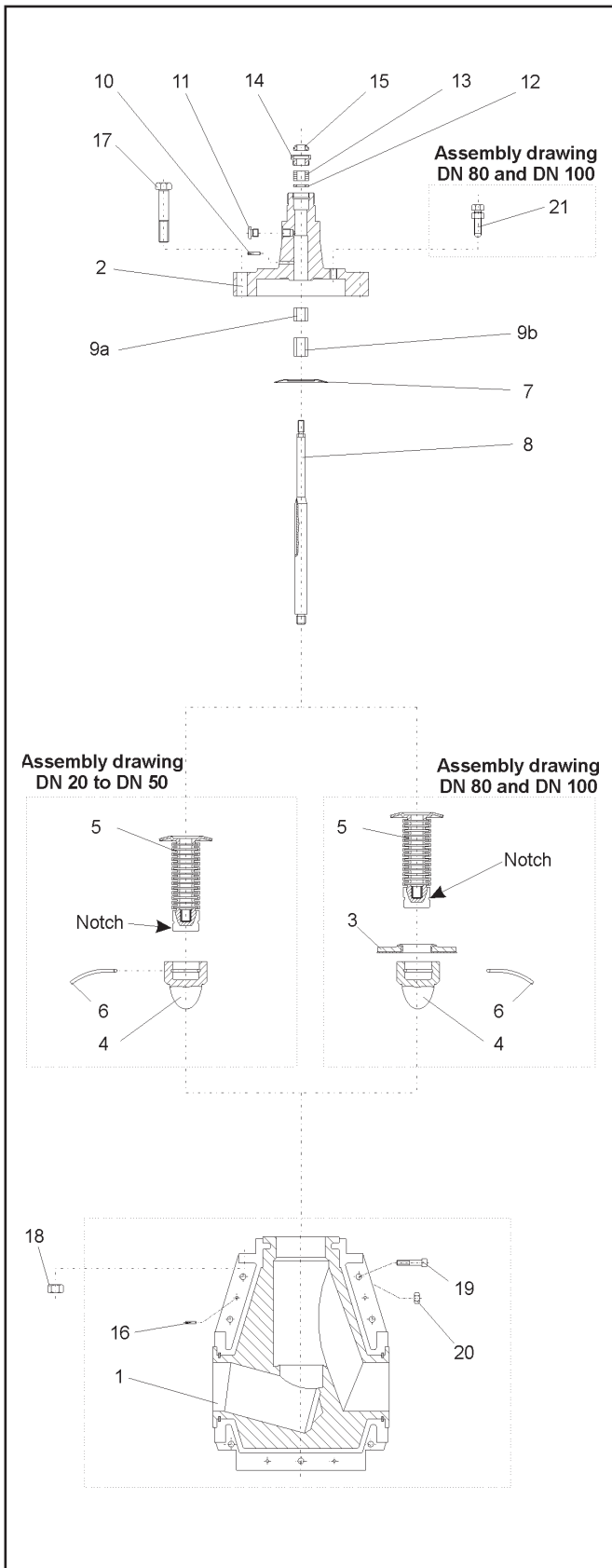

Fig. 3 - Detail drawing of Series 1z Control Valve

Item	Description	Material
1	Body with steel casing	EN-JS 1049 / PTFE
2	Bonnet flange	EN-JS 1049
3	Bordered flange	St 37 / PTFE
4	Plug	PTFE
5	Bellows	PTFE
6	Cord	PTFE
7	Washer	Uniseal 3400
8	Stem connector	1.4571
9	Bushing	Glycodur F
10	Grooved pin	1.4301
11	Locking screw	Steel
12	Washer	1.4571
13	Packing	PTFE-graphite
14	Stuffing box	1.4301
15	Wiper ring	Buna
16	Grooved pin	1.4301
17	Screw	A2-70
18	Nut	A2-70
19	Screw	A2-70
20	Nut	A2-70
21	Screw	A2-70

Table 1 - Parts list and materials of construction

3. Assembly of the control valve

3.1 Preparation for assembly

Before assembling the valve, carefully clean all parts and place them on a soft surface (rubber mat or similar).

Please note that plastic parts are nearly always soft and very sensitive. Take particular care when handling the sealing surfaces to ensure that they do not get damaged.



Note! A high-performance grease paste is used during manufacturing to prevent the screws from cold welding in the bodies (e.g. Gleitmo 805 by Fuchs).

Do not use this lubricant with valves intended for oxygen service. Use a lubricant suitable for valves that are free of grease, especially for oxygen service.



Note! The position and arrangement of the individual parts shown in the detail drawing (Fig. 3) are to be observed during assembly.

3.2 Preassembling the stem

Apply lubricant to the bottom of the thread of the one-pieced stem (8).



Note! Some versions have a stem consisting of three parts with the guide ready-mounted to the stem with a snap ring.

Screw tight the bellows (5) ready-mounted with washer and Ensat bushing onto the greased thread of the stem (8).



Note! Due to the sliding property of PTFE, we recommend using emery cloth to prevent the bellows from slipping when screwing it onto the stem.

3.2.1 Assembling the stem for DN 20 to DN 50

To neatly push the plug onto the stem, make a small notch in the bellows to let air escape.
Push the plug (4) onto the bellows (5). Secure the connection between plug and bellows with PTFE cord (6) inserted as far as it will go. To complete the stem assembly, thoroughly grease the groove of the stem.

3.2.2 Assembling the stem for DN 80 and DN 100

Apply grease to the metal side of the bordered flange (3) to reduce corrosion. Push the bordered flange over the bellows as far as it will go.
To neatly push the plug onto the stem, make a small notch in the bellows to let air escape.
Push the plug (4) onto the bellows (5). Secure the connection between plug and bellows with PTFE cord (6) inserted as far as it will go. To complete the stem assembly, thoroughly grease the groove of the stem.

3.3 Preassembling the bonnet flange

Prior to mounting, grease the inside of the bonnet flange (2). Thread in the screws (21) slightly, so that they do not jut out inside of the bonnet.



Note! Control valves in nominal sizes DN 20 to DN 50 are mounted without the screws (21).

To continue mounting, clamp the bonnet flange with the stem guide facing downwards in a vise.
Insert the Glycodur bushings. If these have different lengths, insert the shorter bushing (9a) into the stem guide as far as it will go with Loctite using a suitable mandrel.
Push the longer bushing (9b) until it is flush with the inside surface of the bonnet, also with Loctite using a suitable mandrel.
Hammer in the grooved pin (10).
Screw in the blanking plug (11).
Insert the washer (7) into the groove of the bonnet flange intended for it.
Place the ready-assembled stem into the bonnet.

3.4 Preassembling the valve body

The valve body (1), made of spheroidal cast iron, forms together with the PTFE-liner a complete unit, which together with the grooved pins, (16) socket head screws, (19) and hexagon nuts (20) are screwed together.



Note:
The assembled valve body unit, must not be disassembled.



Note :
The valve seat is intergrated in the PTFE-Lining and may not be changend or machined.

3.5 Final assembly of the valve

Carefully place the ready-mounted valve body on the bonnet flange.



Note! The pneumatic connection (11) in the bonnet flange and the nameplate on the valve body (1) must face the same direction.

Insert the bolts (17) and position them using the bolts (18). Fasten them evenly in a criss-cross pattern.



Note! Tightening the bolts causes the position of the plug to change. Therefore, make sure that the plug remains centric.

Move the stem (8) while tightening the bolts to test that it can still move easily. If the stem gets jammed, the plug, seat and guide could be damaged as a result.

Mount the stuffing box by first positioning the washer (12) and then insert the packing rings (13) into the bonnet using a special mandrel.



Note! Make sure that the packing rings are inserted offset to ensure the divisions of packing rings do not become aligned.

Press the wiper ring (15) into the gland nut (14). Screw the ready-assembled stuffing box (14) into the bonnet. After tightening it manually, unscrew it by half a turn and retighten it again.



Note! Make sure that the packing is pressed neatly and does not bulge through the stuffing box.

3.6. Travel adjustment

When the valve and Samson actuator are delivered separately, set the dimension A from the top of the stem connector nut to the top of the yoke as specified in Table 2. Check this dimension on assembling the valve and actuator together.

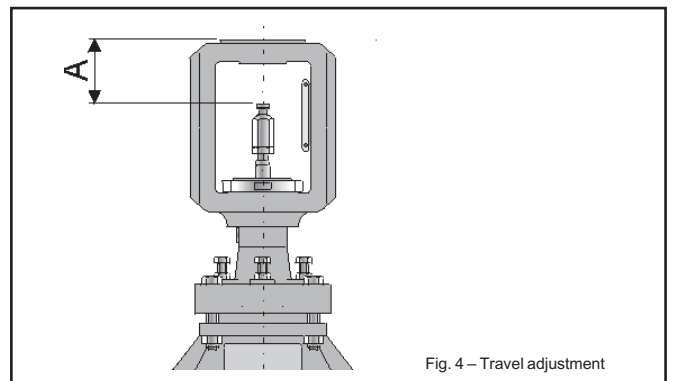

Travel adjustment (Samson actuators) (Valve closed)	
DN	A
20 to 80	75 ± 0,1
100	90 ± 0,1

Table 2 – Travel adjustment

3.7 Travel limitation

- Travel limitation to 15 or 30 mm for fail-safe action "Actuator stem retracts" (fail-open)

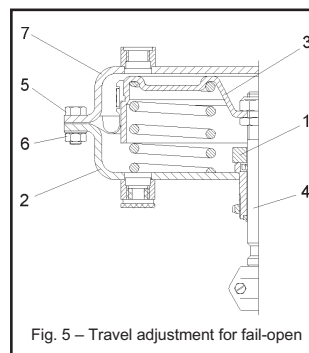

To limit the travel for the fail-open, a spacer (1) is placed between the bottom diaphragm case (2) and the diaphragm plate (3) onto the actuator stem (4).

This spacer is manufactured to size during the assembly of the valve and actuator. The dimensions listed in Table 3 achieve sufficient tight shut-off between the seat and plug.

Actual travel 15 mm	real Actual travel 16 to 17 mm
Actual travel 30 mm	real Actual travel 31 to 32 mm

Table 5 – Actual travel

- To limit the travel, unscrew nuts (6) and bolts (5) and lift off the top diaphragm case (7).
- Carefully take the diaphragm plate (3) together with the actuator stem (4) out of the actuator.
- Slide the spacer (1) over the actuator stem (4).
- Place the diaphragm plate (3), actuator stem (4) with spacer (1) back in the actuator.
- Put back on the top diaphragm case (7) and tighten (6) and bolts (5) evenly in a criss-cross pattern.

• **Travel limitation to 10 mm for fail-safe action**
"Actuator stem extends" (fail-close)

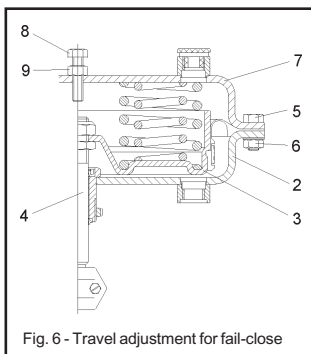

To limit the travel for the fail-close with Kvs 0.005, 0.01 or 0.05 and a 2 mm seat bore, a spacer screw (8) is used.

The maximum travel of 10 mm must not be exceeded. Otherwise, the plug is not guided in the seat anymore when the valve opens and would be damaged or break off when the valve closes again as the guidance in the seat is not guaranteed anymore.

- To limit the travel, drill a hole in the top diaphragm case (7) with a corresponding thread for an M10x1 screw.
- After mounting the actuator on the valve, screw the M10x1 screw (8) with lock nut (9) screwed onto it into the thread.
- This screw (8) is used to limit the travel by adjusting it exactly and locking the position with the lock nut (9).

4. Troubleshooting

Refer to section 7 of **Operating Instructions**

- < **BA 01a-01_EN** > for pneumatic valves or
- < **BA 01a-02_EN** > for manually operated valves.

5. Repair of the control valve

5.1 Replacing the bellows

If a leak is detected at the leak-off connection (11), the bellows (5) may be defective. We recommend checking the condition of the bellows.

To remove the bellows, disassemble the valve in reverse order to that described in section 3. Check the bellows and all plastic parts for damage. In case of doubt, replace the parts with new ones.

5.2 Replacing the bellows and packing

If the valve leaks at the packing, the packing (13) and the bellows (5) may be defective. We recommend checking the condition of all the seals and the bellows.

To remove the packing and the bellows, disassemble the valve in reverse order to that described in section 3.

Check the packing and bellows including all plastic parts for damage. In case of doubt, replace the parts with new ones

5.3 Further repair work

In case of severe damage, we recommend the repair work to be carried out by Pfeiffer.

6. Customer inquiries

Should you have any inquiries, please submit the following details:

1. Order number (embossed on the nameplate)
2. Type, product number, nominal size, and version of the valve
3. Pressure and temperature of the process medium
4. Flow rate in m³/h
5. Installation sketch, if possible

For your special requirements please contact our technical sales department.

Pfeiffer Chemie-Armaturenbau GmbH

Hooghe Weg 41 • 47906 Kempen • Germany
 Phone: +49 2152 2005 - 0 • Fax: +49 2152 1580
 E-Mail: vertrieb@pfeiffer-armaturen.com • www.pfeiffer-armaturen.com

Specifications subject to change without notice.