

Pocket free piggable End station Series 28z

Application:

Stainless steel - valve as end station with product outlet, product inlet in 1-Pigging system.

- Nominal diameter DN 50 to DN 150,
- Nominal pressure PN 25, PN 40,
- Temperature up to 200°C.

The valve consists of a piping piece with an incorporated, pig gripping device, intergrated shut off ball valve, all the necessary pigging drive control connecting ports, and an emergency drainging outlet. The equipment displayed in the modular kit system show the following special features:

- Pipe inside diameter acc. to DIN 2430,
- solid dimensioned pig retainer, to protect the pig.
- Sealing rings, one side spring loaded,
- floating ball, i.e. sealed by both sealing rings,
- control shaft sealed by a pre-loaded spring washer v-ring packing,
- blow out proof control shaft,
- anti static design by conductable shaft bearing.
- Variable flange with sealing strips in form B1 or in form B2 acc. DIN EN 1092-1, straight flow with special kick back spring, specially for systems, or specifically designed according to customer requiremenst,
- mounting extension flanges for connections acc. DIN ISO 5211.

Designs:

End station Series 28z optionially in the following designs:

- End station with Hand-lever or manual gearbox.
- End station with pneumatic multi turn actuator (for details please see respective data sheet).

The valve, which because of the directly mounted shut-off ball valve, enables an almost pocket free pigging, and performs the following functions according to the various types of designs:

- in 1-Pig system: - as end station with product outlet i.e. product inlet.

Special designs:

- with pigging signal strips by automatic. systems, for the fitting of magnet inductive pigging sensors,
- with pigging sensors for manual detection.



Fig. 1 - manual End station series 28z with mounted control panel series 28s

End station Series 28z

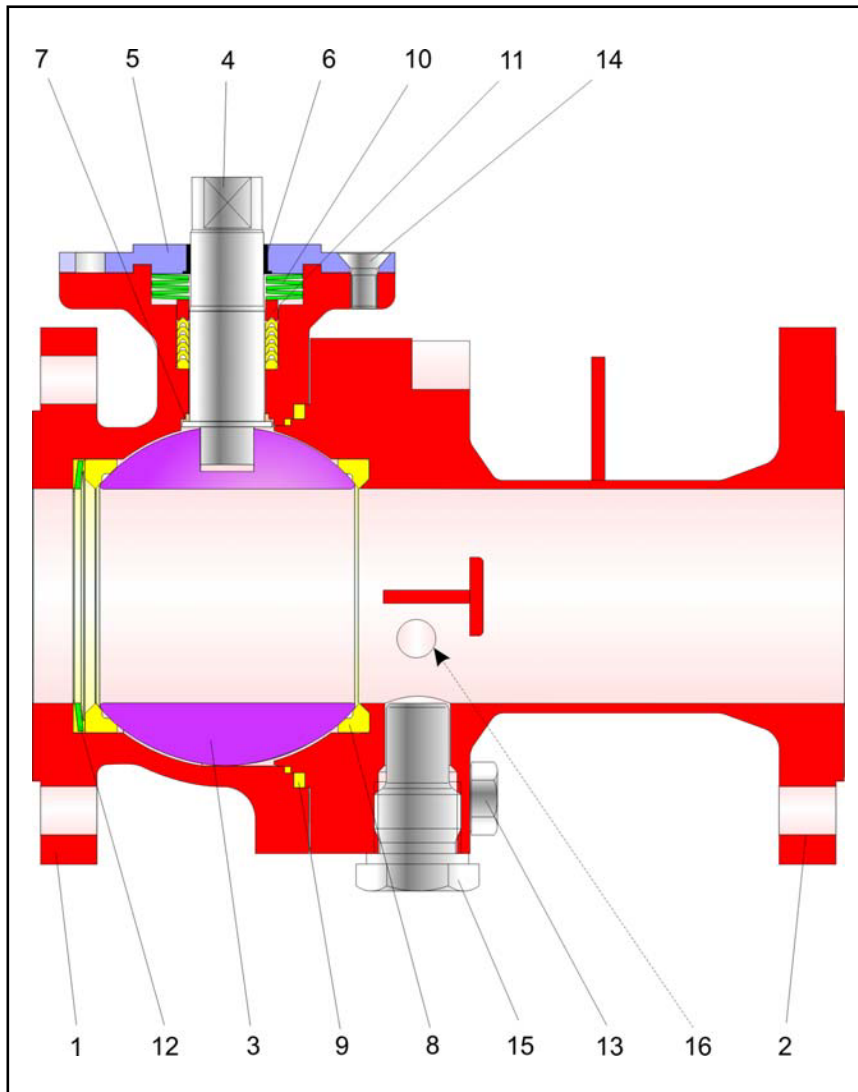

Fig. 2 - Sectional drawing of End station Series 28z

Additional equipment and attachment parts:

For the control valves the following accessories are available, either separately, or in combination:

- Hand-lever or manual gear box (90°)
- Control shaft extension (100mm),
- Interchangeable pneumatic, and electric quarter-turn actuators,
- limit switch.
- magnet solenoid valves,
- filter - regulators,

further attachments are available according to customer specifications.

Function- and operation mode:

The pigging End-station of series 28z permits full through flow in both directions. The pig is then stopped in the valve.

The ball (3) with its cylindrical passage, is rotatable around the middle axis (4). The angle opening of the ball valve determines the flow between the surface of body (1) and surface of ball passage. The external control shaft is equipped with a hand lever. Optionally, a pneumatic actuator or a manual gear-box can be fitted. The sealing of the ball (3) is provided by interchangeable seat rings (8). The control shaft is sealed by a PTFE-packing (11). The pre-loaded tension is implemented with spring washers (10) which are positioned above the packing.

Pos.	Description	Pos.	Bezeichnung
1	Main body	9	Body sealing
2	Body	10	Set of spring washers
3	Ball	11	V-ring packing
4	Control shaft	12	Spring washer
5	Stuffing box flange	13	Screw
6	Bearing bushing	14	Screw
7	Bearing bushing	15	Screw plug
8	Set of sealing rings	16	Screw plug

Table 1 - Parts list



Note:

Before the use of Ball valves in Ex-areas, the application must be in accordance with ATEX 94/ 9/EG, please observe the operating instructions! <BA 28y>



Safety position:

Depending on the mounting of the pneumatic quarter turn actuator, has two safety positions, which by e.g. pressure release, or failure of air supply, become active:

- **Ball valve with actuator „ Spring closes „:**
On failure of air supply, the ball valve closes. The opening of the ball valve occurs by increasing the air supply pressured against the force of the springs.
- **Ball valve with actuator „ Spring opens „:**
On failure of air supply the ball valve opens. The closing of the ball valve occurs on increasing air supply pressure against the force of the springs.

Advantages of the pre-loaded sealing system:

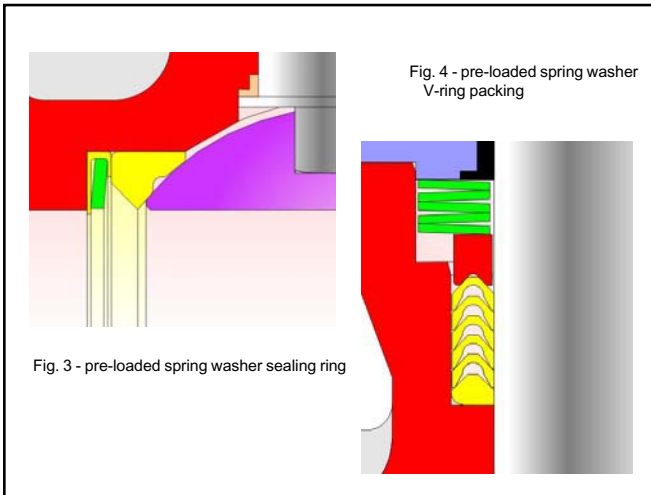

- maintenance free and self adjusting,
- two active sealing rings,
- highest sealing tightness, even by extreme pressure- and temperature variations,
- longer service life,
- reduced increase in torque by rising temperature, therefore smaller actuator required,
- **Conclusion:**
much higher level of Efficiency!

General technical data:

Nominal diameter	DN 50 to DN 150
Nominal pressure	PN 25 / 40
Temperature range	up to 200°C
Ball sealing	TFM (PTFE)
Leak rate	Leak rate A acc. DIN EN 12266-1, Test P12 (Leak rate 1 BO acc. DIN 3230 part 3)
Flanges	DIN EN 1092-1, variable form
Stuffing box packing	Pre-loaded spring washer PTFE - V-ring packing

Table 2 - technical data

Materials:

Main body	1.4571 / 1.4408
Body	1.4571 / 1.4408
Ball	1.4408
Control shaft	1.4571
Sealing rings	TFM (PTFE)
Spring washer	1.4122 lined with PTFE-white
Stuffing box packing	PTFE - V-ring-Packung with spring washers made from 1.8159
lower bearing sleeve	PTFE with 25% Glass
top bearing sleeve	PTFE with 25% Carbon
Body sealing	PTFE / EPDM

Table 3 - Materials

Optional material combination:

- Control shaft and Ball on request,
- sealing rings in PTFE-compounds,
- metall sealing system,
- sealing in Graphite.

Pressure - Temperature - Diagram:

The area of application is determined by the Pressure-Temperature-Diagram.

Process data und medium can affect the values in the Diagram.

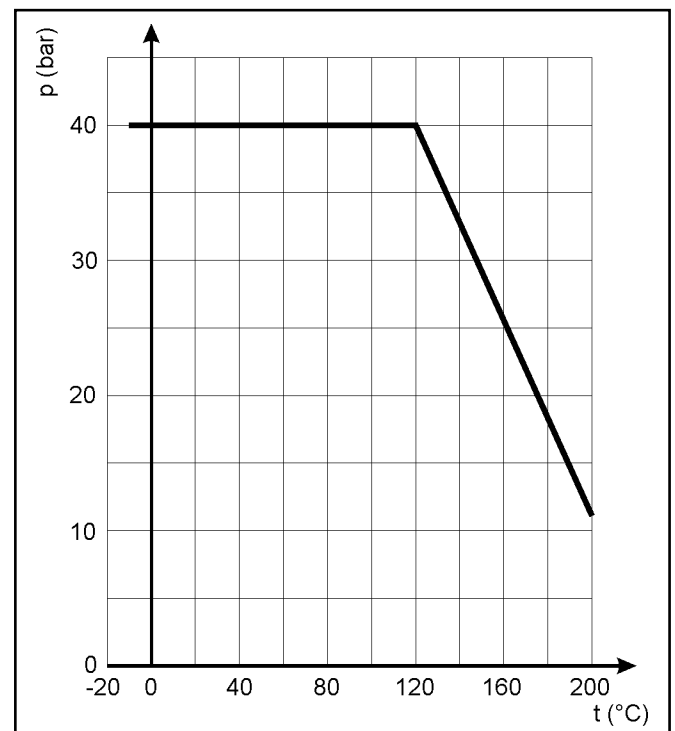

Fig. 5 - Pressure-Temperature-Diagram

Torque and breakaway torques:

DN	Pressure variation Δp in bar		Md in Nm	Mdl in Nm							
	0	2		4	6	8	10	16	25		
50	226	497	17	25	28	32	36	40	43	55	71
80	437	961	49	70	79	89	98	108	118	146	190
100	749	1647	77	110	125	140	155	170	185	230	297
150	1497	3293	161	230	263	297	330	364	398	498	650

Tabelle 4 - max. zulässiges Drehmoment, erforderliche Drehmomente und Losbrechmomente

The breakaway torques specified are average values, which were measured with air at 20°C with the corresponding differential pressures.

Operating temperature, process medium, and long operating times may affect, and change the permissible torques and breakaway torques.

Measurements and Weights:

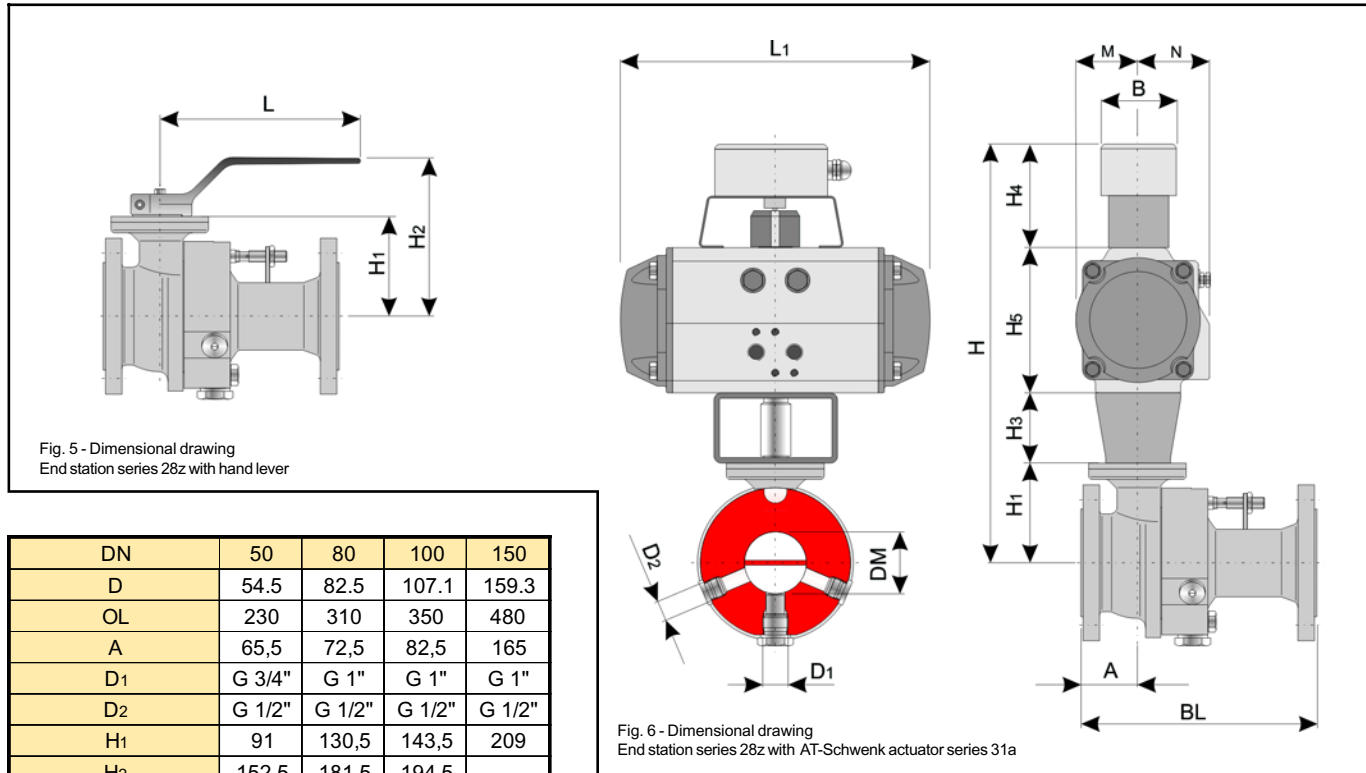

Fig. 5 - Dimensional drawing
End station series 28z with hand lever

Fig. 6 - Dimensional drawing
End station series 28z with AT-Schwenk actuator series 31a

DN	50	80	100	150
D	54.5	82.5	107.1	159.3
OL	230	310	350	480
A	65,5	72,5	82,5	165
D ₁	G 3/4"	G 1"	G 1"	G 1"
D ₂	G 1/2"	G 1/2"	G 1/2"	G 1/2"
H ₁	91	130,5	143,5	209
H ₂	152,5	181,5	194,5	-
L	207	350	350	-
Actuator	150-5	300-5	600-5	1200-5
H	H ₁ + H ₃ + H ₄ + H ₅			
H ₃	60	80	80	90
H ₄	110	110	110	110
B	80	80	80	80
DIN/ISO Connection	F07	F10	F10	F14
Weight	25	40	62	127

Selection and lay-out design of End station:

1. Calculation of the required nominal diameter.
2. Selection of the valve in accordance with Table 2, Table 3 and the pressure-temperature-diagram.
3. Selection of appropriate actuator with the assistance of table 4.
4. Selection of additional equipment

Actuator SRP	150	300	600	1200
L ₁	268.5	345	437.5	543
H ₅	127	157	196	245
M	56	69.5	88	110
N	67	82	99	112
Weight	6.3	12.2	23.3	43.5

Table 5 - Measurements in mm and Weights in kg, Actuator series 31a for air supply 5 bar

Ordering text:

pigging End station Type: series 28z,
 DN / PN , optional. special design
 Control valve (manufacturer):
 Supply pressure: bar,
 Safety position:
 Limit switch (manufacturer):
 Solenoid valve (manufacturer):
 Others:

For your special requirements, please contact our technical sales department.

Pfeiffer Chemie-Armaturenbau GmbH

Hooghe Weg 41 • 47906 Kempen

Telephone: +49 (0)2152 / 2005-0 • Telefax: +49 (0)2152 / 1580

E-Mail: vertrieb@pfeiffer-armaturen.com • Internet: www.pfeiffer-armaturen.com

Amendments to requirements and design are subject to modification