

Assembly and repair instructions

Metering valve Series 28a



Fig 1 - Metering valve Series 28a with AT- Actuator Series 31a



This equipment may only be dismantled and disassembled by skilled personal, who are familiar with the assembly, start-up and operation of this product.

Skilled personal in the sense of these repair and assembly instructions are persons, who as a result of their training, experience and knowledge of the relevant standards, are able to judge the tasks assigned to them, and to recognise possible dangers.

1. Design, operation and dimensions

Design, operation and dimensions, also all further technical details can be found in the **Data sheet < TB 28a_EN >**

2. Installation, start-up and maintenance

Guidelines for the installation, start-up and maintenance can be found in the **Operating instructions**

< BA 28a-01_EN > for automatic metering valves, i.e.

< BA 28a-02_DE > for manually operated metering valves.

0. Introduction

These instructions are intended to support the user in the assembly and repair of metering valves for series 28a.

Technical details, as a result of further development of the valves mentioned in these instructions are subject to modification without notice.

The text and illustrations do not necessarily display the scope of supply, or an eventual order of spare parts. Drawings and graphics are not to scale. Customer related designs, which are not in accordance with our standard offer, are not shown.

The transfer of these instructions to third parties is only allowed with written approval of Pfeiffer Chemie-Armaturenbau GmbH.

All documents are protected according to the laws of the German Copyright Act. The transmission and / or duplication of documents, even in abstracts, also the exploitation and communication of contents is not permitted, unless expressly granted.

Violations are an offence and liable to claims for damages. We reserve all rights for the exercise of industrial property rights.

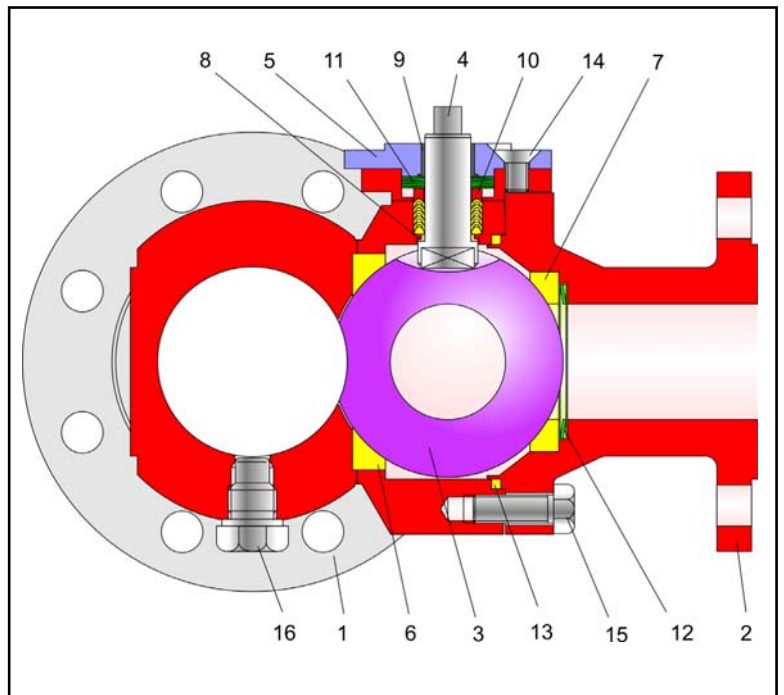

Fig. 2 - Sectional view of a metering valve series 28a => Parts list see table 1 on page 2

Metering valve Series 28a

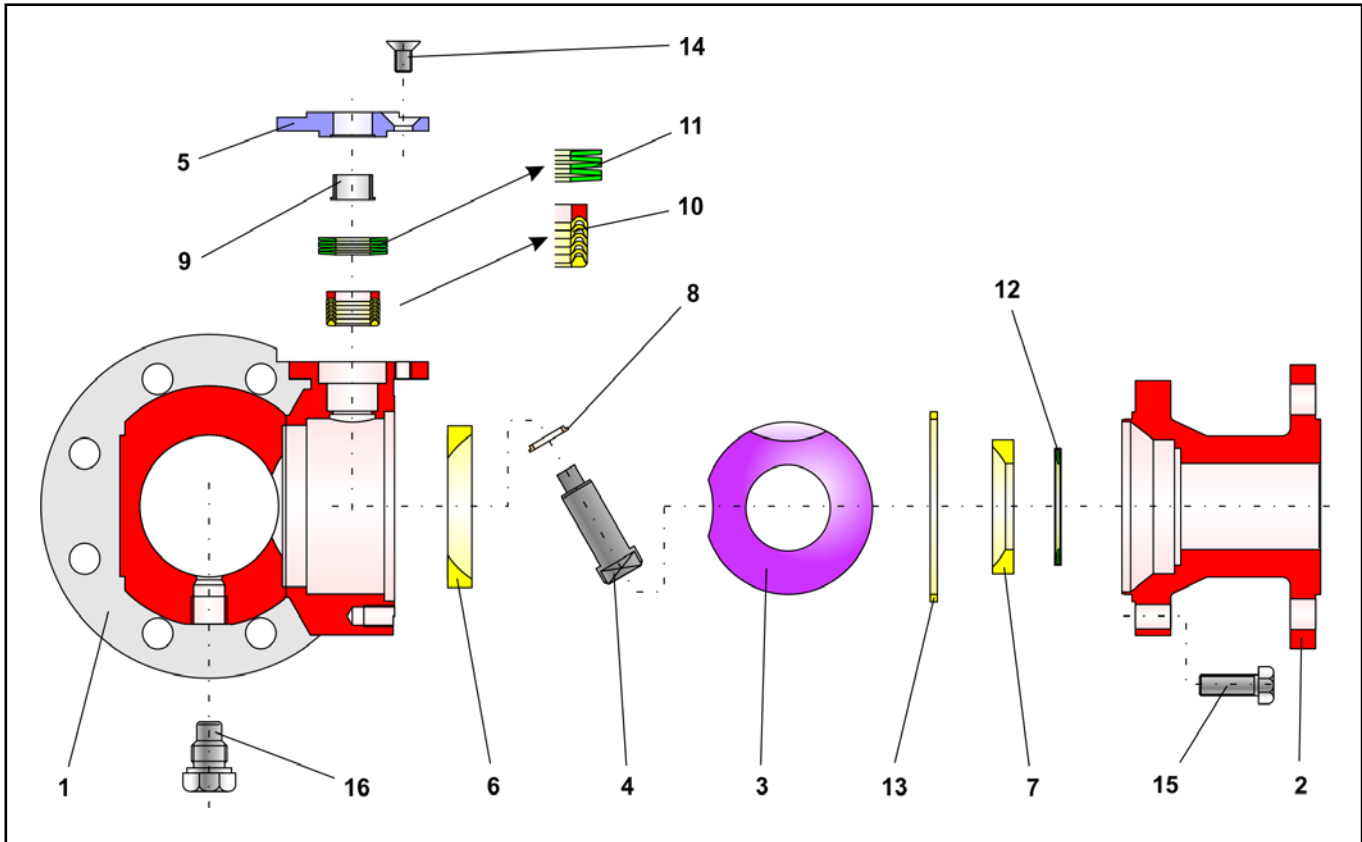

Fig. 3 - Explosion drawing of metering valve, series 28a

Pos.	Qty.	Description	Material	S-Part
1	1	Main body	1.4408 / 1.4571	
2	1	Side body	1.4408 / 1.4571	
3	1	Ball	1.4408 / 1.4571	
4	1	Control shaft	1.4571	
5	1	Stuffing box flange	1.4571	
6	1	Sealing seat	TFM (PTFE)	S
7	1	Sealing seat	TFM (PTFE)	S
8	1	Bearing bush	PTFE with glass	
9	1	Bearing sleeve	PTFE with carbon	
10	1	V-ring packing	1.4305 / PTFE	S
11	1	Spring washer set	1.8159 / Delta tone	S
12	1	Spring washer	1.4404 / PTFE	S
13	1	Body sealing	PTFE	S
14	4	Screw	A2-70	
15	var	Screw	A2-70	
16	1	Plug screw	1.4571 / PTFE	

Table 1 - Parts list

3. Assembly of the metering valve

3.1 Preparation for assembly

To assemble the metering valve, clean all parts thoroughly and lay them carefully on a soft padded surface (rubber mat or similar).

Take into consideration, that parts made of plastic are generally soft and sensitive, in particular the sealing surfaces must be handled with care, and not be damaged.



Attention: To avoid cold corrosion of the screws in the bodies, the manufacturer has used a high performance lubricating grease (Gleitmo 805. from. Fuchs).

This grease however, may not be applied to valves which are used in an oxygen environment. Valves which must be free of grease, especially for use in oxygen, an appropriate lubrication must be used.



Note: The position and arrangement of the individual parts shown in the explosion drawing must be observed when assembling the valve.

3.2 Assembly of the main body

The assembly begins with the main body (1).
Place the sealing seat (6) in the main body.
With a slight rotating movement, push the bearing sleeve (8) onto the control shaft (4). The control shaft (4) with the bearing sleeve (8) is guided from the inside of the main body (1) through the opening for the control shaft.



Note: The sealing surface of the control shaft (4) must not be damaged. Also make sure that the bearing sleeve (8) and the control shaft (4) are vertical, when positioned in the opening for the control shaft, and not slanted.

Rotate the control shaft (4) so that the two flats are positioned vertical to the working surface.
Now carefully insert the ball (3).

Place the body sealing (13) in the turned recess in the main body (1)

3.3 Assembly of the side body

Insert the lined spring washer (12) in the body (2). For the assembly position of the spring washer, refer to drawing (Fig. 3)
Press the sealing seat (7) onto the spring washer.

3.4 Final assembly of the metering valve

The side body (2) together with the sealing seat (7) is carefully pressed onto the main body (1).

Rotate the side body (2) until the bores of both body parts (1 and 2) are aligned with each other.
After applying grease to the screws (15) both parts (1 and 2) are screwed together, evenly and in alternating pattern.

With a light rotating movement, press the V-ring packing (10) over the control shaft (4) and place in the packing chamber of the main body (1). For the positioning of the V-rings, refer to the explosion drawing (Fig. 3).

Now the spring washer set (11) is placed on the V-ring packing. Also here, refer to the explosion drawing (Fig. 3) for positioning the spring washers.

Press the bearing bushing (9) into the stuffing box flange (5).
Following this, place the stuffing box flange (5) over the control shaft, and mount onto the main body. After applying grease to the socket head screws (14) align and tighten evenly in alternating pattern.



Note: Before testing for leakage tightness, the valve should be operated several times to enable the ball to centre and sit correctly in the sealing seats, therefore ensuring a good sealing function.

Assembly of the ball valve is now completed.

4. Trouble shooting

Action to be taken in the case of malfunction is described in the **Operating instructions in section 7**
< BA 28a-01_EN > for automatic metering valves, i.e.
< BA 28a-02_EN > for manually operated metering valves

5. Repairing the metering valve

5.1 Replacing the V-ring packing

If leakage is located at the stuffing box, the PTFE-rings of the V-ring packing may be defect. It is therefore recommended to check the condition of the packing.

To dismantle the V- ring packing, proceed in reverse order to the assembly instructions, as described in section 3.

As with all other plastic parts, check the PTFE-rings of the V-ring packing for damage, and if necessary replace these parts.

5.2 Replacing the sealing seat and ball

If leakage is located at the flow through bore in the metering valve, the sealing ring set and the ball may be defect. Is therefore recommended to check these parts. To dismantle the sealing rings and ball, proceed in reverse order to the assembly instructions as described in section 3.

As with all other plastic parts, proceed to check the sealing rings and ball for damage, and if necessary replace these parts.

5.3 Further repairs

We recommend larger repairs to be carried out in our works in Kempen, by our highly skilled team at Pfeiffer.

6. Customer inquiries

(by inquiries, please state the following)

1. Commission number (embossed on the type plate).
2. Type, manufacturing no. nominal diameter, and version of metering valve.
3. Pressure and temperature of the media flow.
4. Through flow in m³/h.
6. Possible circuit diagram.

For your special requirements, please contact our technical sales department.

Pfeiffer Chemie-Armaturenbau GmbH

Hooghe Weg 41 • 47906 Kempen
Telefon: 02152 / 2005-0 • Telefax: 02152 / 1580
E-Mail: vertrieb@pfeiffer-armaturen.com • Internet: www.pfeiffer-armaturen.com

Specifications and versions are subject to change without notice