



PTFE - lined Ball valve BR 20a

Application:

Tight-closing PTFE-lined ball valve for corrosive media, especially for high process demand in chemical plants:

- Nominal sizes DN 15 to DN 200 and NPS1 to NPS8
- Nominal pressure PN 16 and ANSI cl150
- Temperature range -10°C to 200°C (14°F to 392°F) (others on request)

The controlling device consists of a PTFE-lined ball valve with a pneumatic quarter-turn actuator, a manual gear or a lever.

The valves are designed according to the modular-assembly principle have the following features:

- Full bore, high KV values
- Body of EN-JS 1049 (0.7043 / A395) with PTFE-liner (min. 5 mm wall thickness)
- Exchangeable PTFE seat rings
- 1 pcs ball/stem of stainless steel (1.4313) with PTFE liner (min. 5 mm wall thickness)
- Hysteresis-free, perfect for control applications
- Shaft sealed by a self-adjusting PTFE V-ring packing, supported by disc springs, maintenance-free
- On/off operation with leakage rate A acc. to DIN EN 12266-1, bubble-tight version
- Blowout-proof shaft
- Connecting flange for actuators acc. to DIN ISO 5211
- DIN version with face-to-face dimensions acc. to DIN EN 558, row 1
- ANSI version with face-to-face dimensions acc. to DIN EN 558, row 3
- High-quality 2-component PU coating (RAL 9005) as protection against corrosive atmosphere and corrosive formation

Versions:

BR 20a ball valve are optionally available in the following versions:

- Ball valve with lever (DN 15 to 100 or NPS1 to NPS4)
- Ball valve with manual gear
- Ball valve with pneumatic quarter-turn actuator (see associated data sheet for details)
- Acc. to customer specifications

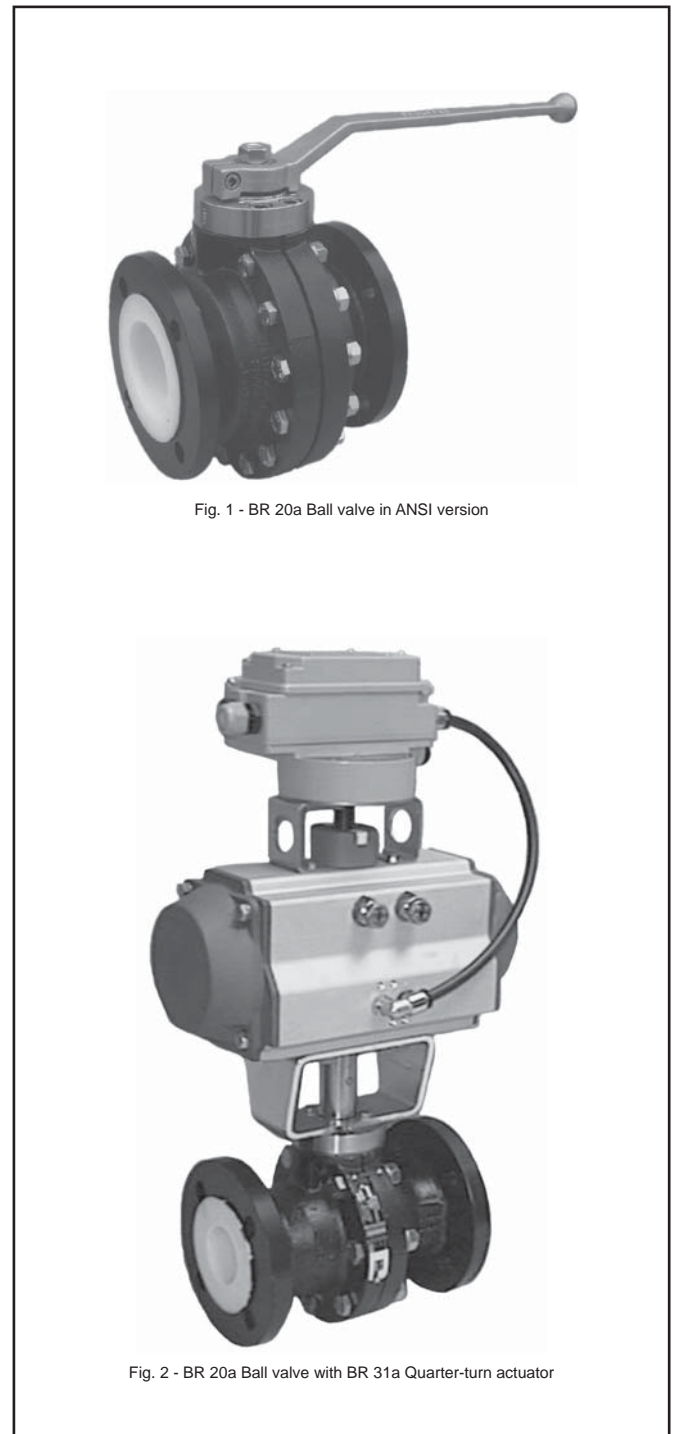

Fig. 1 - BR 20a Ball valve in ANSI version

Fig. 2 - BR 20a Ball valve with BR 31a Quarter-turn actuator

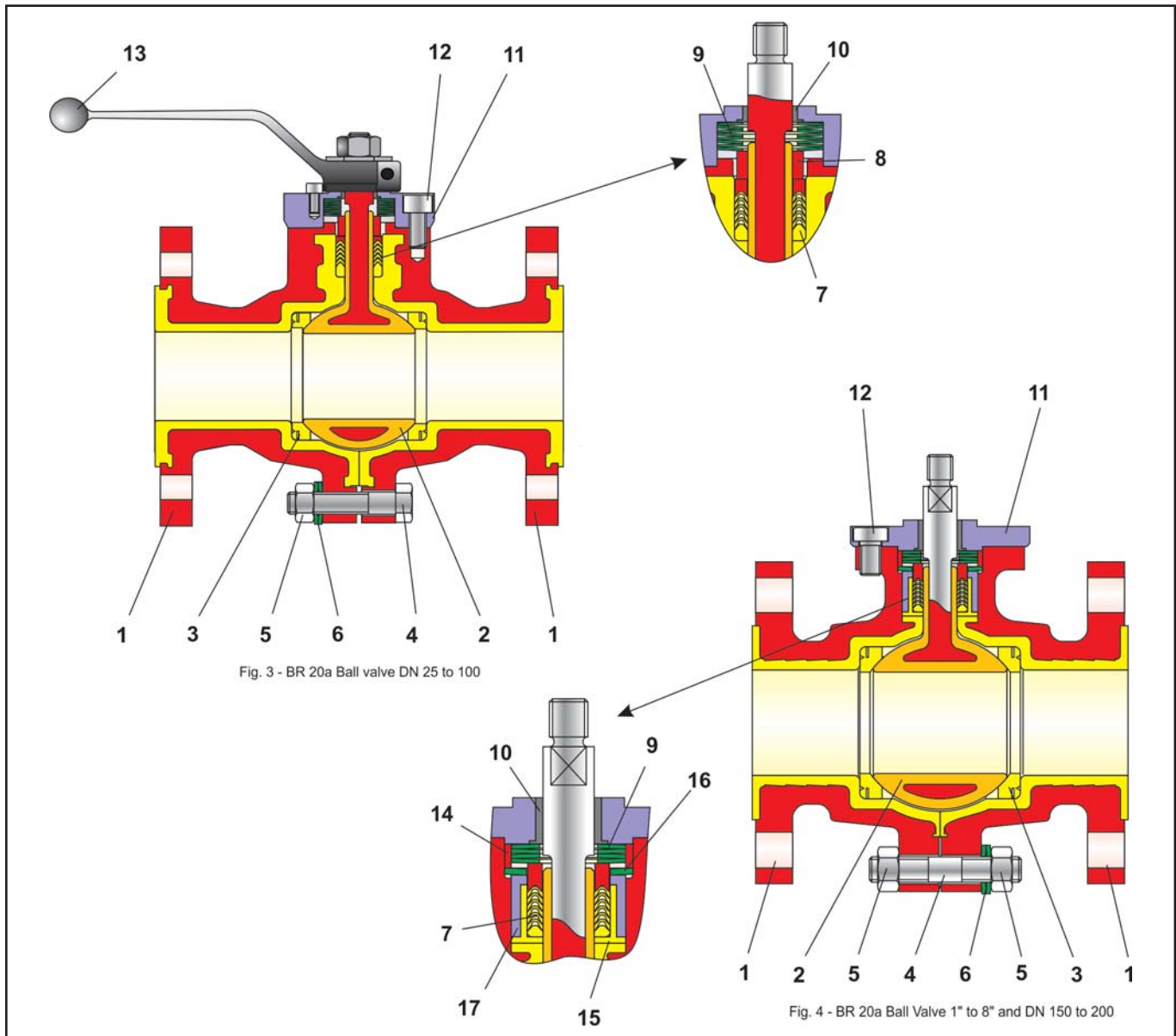

Fig. 3 - BR 20a Ball valve DN 25 to 100

Fig. 4 - BR 20a Ball Valve 1" to 8" and DN 150 to 200

Item	Description
1	Body with lining
2	Ball with coating
3	Seat ring
4	Screw / Stud bolt
5	Nut
6	Disc spring
7	V-ring packing
8	Thrust ring
9	Disc spring set

Item	Description
10	Bearing bush
11	Gland flange
12	Screw
13	Lever
14	Centering ring
15	PTFE bush
16	Disc spring
17	Bush

Table 1 - Parts list

Special versions:

- Valve body made of stainless steel 1.4571
- Lined bottom drain ball valve, see Series 21a
- Ball valve for controlling by characteristic seat ring
- Liner with special PTFE compounds
- Lining PTFE - conductive
- Heating jacket, stainless steel
- Stem sealing with two PTFE V-ring packings and test connection
- Flange groove acc. to DIN EN 1092
- Several materials for ball and sealing rings
- FDA conform sealing materials
- Acc. to customer specifications

Principle of operation:

The BR 20a Ball Valves allow the full flow through the valve in either direction.

The ball (2) with its cylindrical passage slew around the middle axis. The opening angle of the ball determines the flow through between the body (1) and bore. When the ball valve is opened, the entire profile is available.

The ball (2) is sealed by exchangeable seat rings (3).

The ball shaft is sealed by a PTFE V-ring packing (7) which is spring supported by disc springs (9) positioned above the packing.

The shaft is equipped with a lever (13). Optionally, a pneumatic actuator or gear-operated actuator can be assembled.



Fail-safe position:

Depending on assembly position of the pneumatic actuator, the valve has two fail-safe positions which become effective when the air pressure in the actuator is relieved or when the supply air fails:

• **Ball valve with fail-close actuator**

While air failure, the valve is closed. The valve opens when the signal pressure increases, acting against the force of the springs.

• **Ball valve with fail-open actuator**

While air failure, the valve opens. The valve closes when the signal pressure increases, acting against the force of the springs.



Note:

BR 20a Ball valves can also be used for control applications. Refer to the data sheet <DB 20a-kd>.



Note:

Before using the valve in hazardous areas, check whether this is possible according to ATEX 2014/34/EU by referring to the operating instructions <BA 20a>.

Optional material combinations:

For best adaption to process conditions, it is possible to optimize ball valve by modification of materials (eg. body, shaft, ball and sealing).

Additional accessories:

The following accessories are available (separately or in combination):

- Locking device
- Shaft extension (100 mm, standard)
- Pneumatic or electric quarter-turn actuators
- Positioner
- Limit switches
- Solenoid valves
- Filter regulator
- Heating jacket
- Ball valve for control application by characteristic seat ring

Further accessories are possible on customer request.

Advantages of the live-loaded sealing system:

- Maintenance-free and self-adjusting
- Highest tightness, even under extreme pressure and temperature conditions
- High durability
- **All in all: Extremely economic!**

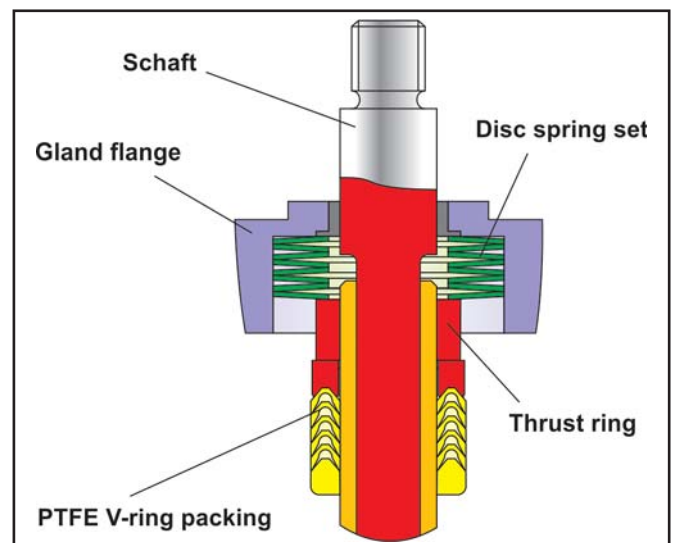

Fig. 5 - Live-loaded sealing system



Pressure-temperature diagrams:

The operating range is given by the pressure-temperature diagram. Process data and medium may influence the values in the diagram.

Pressure-temperature diagram, PN 16

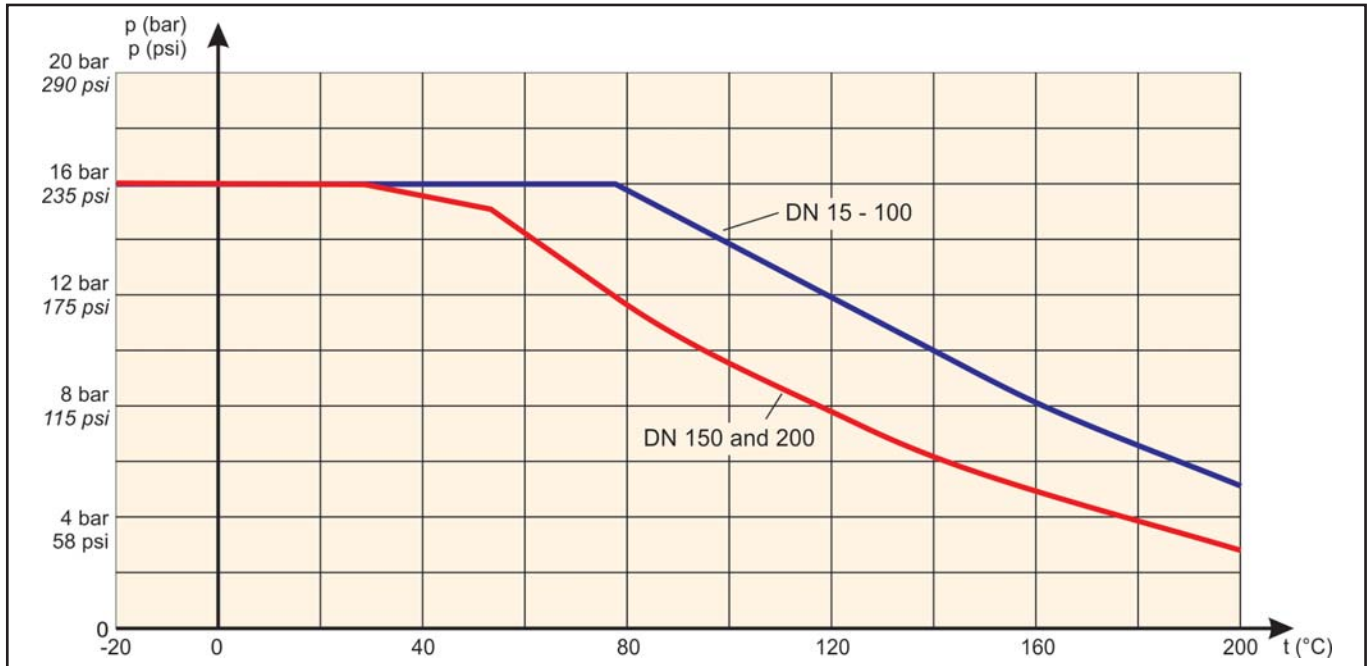

Fig. 6 - Pressure-temperature diagram, PN 16

Pressure-temperature diagram, Class 150

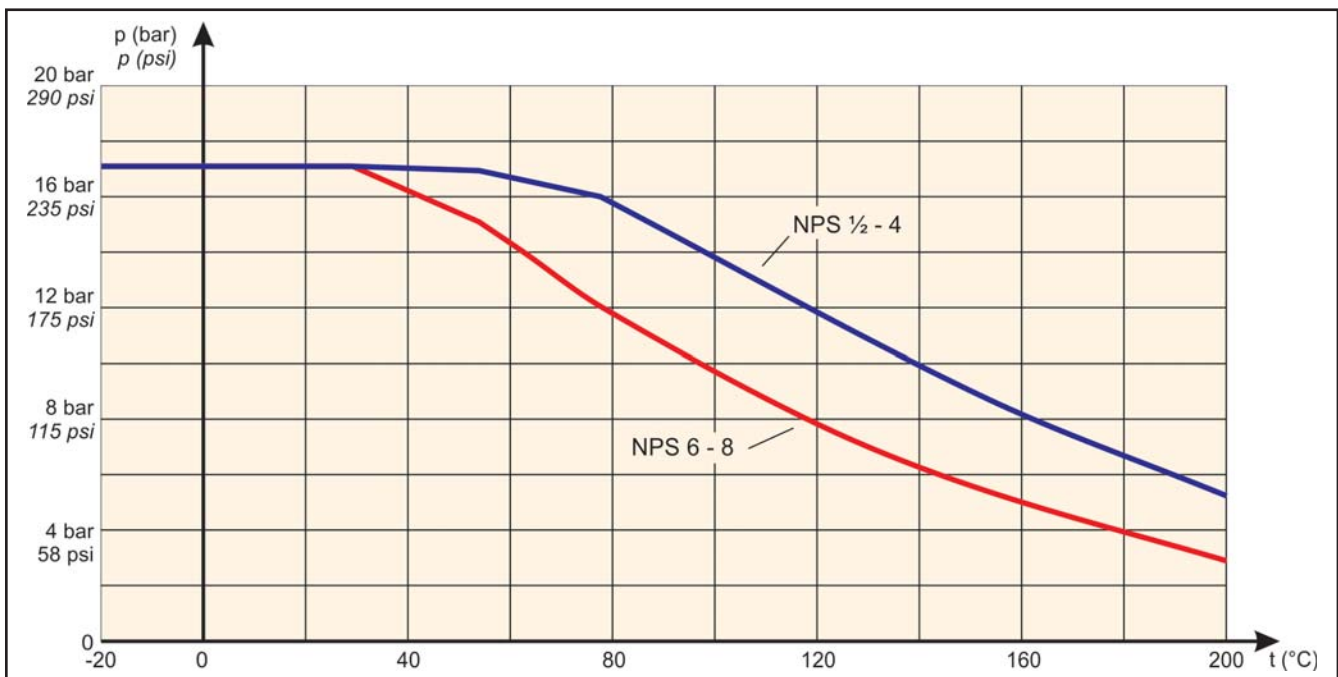

Fig. 7 - Pressure-temperature diagram, Class 150

General technical data:

	DIN	ANSI
Nominal size	DN 15 to DN 200	NPS1 to 8
Nominal pressure	PN 16	cl150
Temperature range	-10°C to 200°C (14°F to 392°F)	
Ball sealing	Virgin PTFE	
Leakage rate	Leakage rate A acc. to DIN EN 12266-1, P12 (leakage rate 1 BO acc. to DIN 3230 Part 3)	
Flanges	DIN EN 1092-2, Form B	ASME B16.34
Packing	PTFE V-ring packing supported by disc springs	
Face to face dimensions	DIN EN 558, row 1	DIN EN 558, row 3

Table 2 - Technical data

Materials:

	DIN	ANSI
Body	EN-JS 1049 / 0.7043 with PTFE-lining (min. 5mm)	A395 with PTFE-lining (min. 5mm)
Ball / Shaft	1.4313 / 1.4317 with PTFE-casing (min. 5mm)	
Seat rings	Virgin PTFE	
Packing	PTFE - V-ring-packing	
Disc spring set	1.8159, Delta Tone	
Bearing bush	PTFE with 25% carbon	
Body sealing	PTFE	
Coating	Two-component polyurethane coat, black (RAL 9005)	

Table 3 - Materials

kvs and Cv coefficients:

DN	15	25	40	50	80	100	150	200
NPS	½	1	1 ½	2	3	4	6	8
kvs	10	45	105	163	402	587	1884	3994
Cv	12	52	122	190	467	682	2191	4645

Table 4 - kvs and Cv coefficients

Torques and breakaway torques:

		Differential pressure Δp in bar		0	5	10	16
DN	NPS	perm. operating torque MDmax. in Nm	required operating torque Md in Nm	Losbrechmoment Mdl in Nm			
15	-	126	6	10	10	10	12
25	1	140	5	7.5	10	14	17
40	1 1/2	140	10	15	15	18	22
50	2	140	15	22.5	23	28	34
80	3	608	38	57	62	80	90
100	4	833	60	90	110	130	140
150	6	1570	210	300	380	450	540
200	8	6515	270	380	430	505	570

Table 5 - Max. permissible torque, required torque and breakaway torque

The above listed torques are based on the opening of the ball valve at the differential pressure for water with corrosion inhibitors added at room temperature and with one-day non-actuation.

Since temperature, pressure, process medium, switching frequencies and idle times considerably affect the arising torques, corresponding factors need to be taken into consideration on selecting and sizing the actuator. In case of doubt, contact Pfeiffer.

The listed maximum permissible torques apply to the standard material listed in Table 3.



Dimensions and weights:

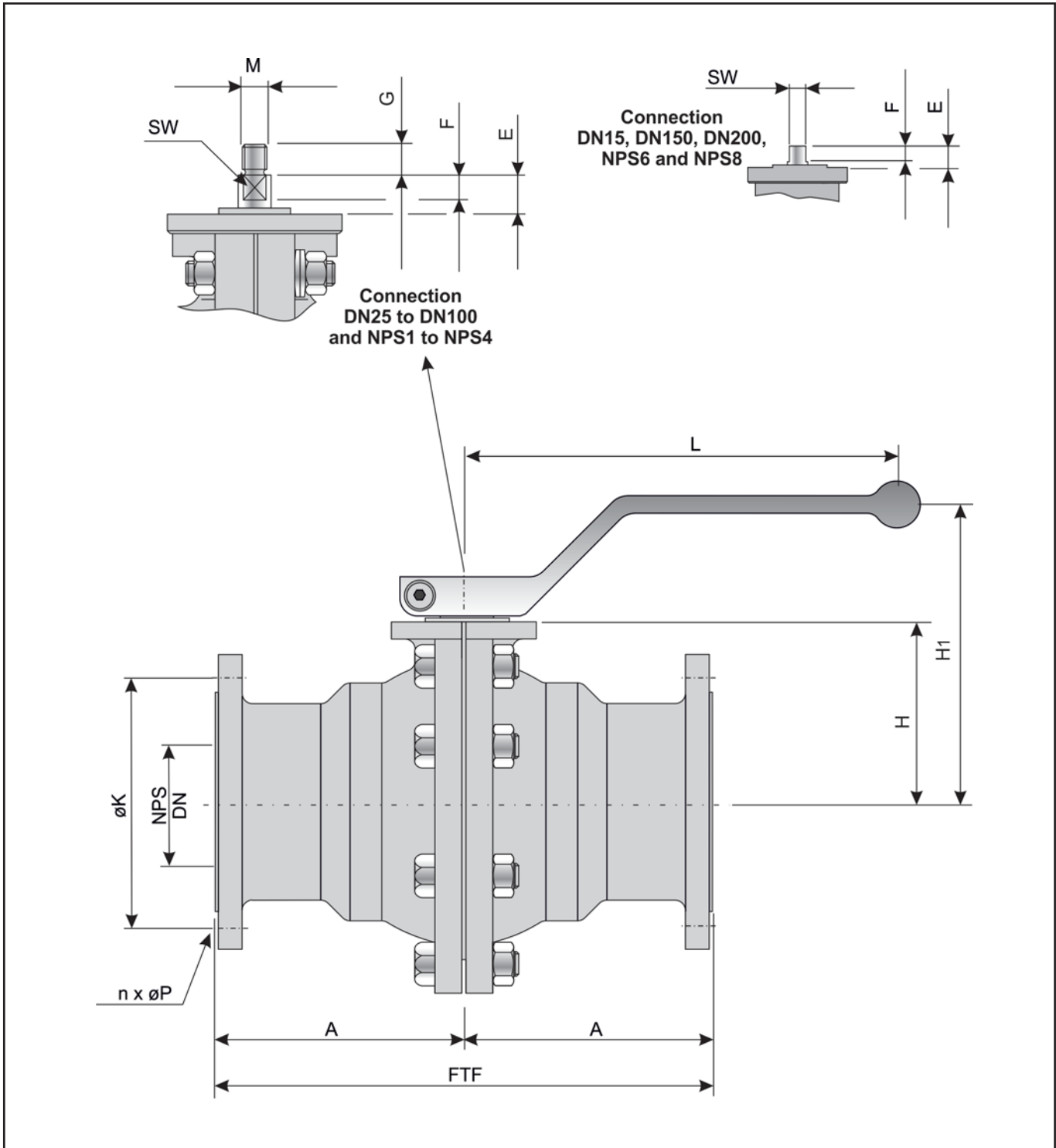

Fig. 8 - Dimensions in mm and weights in kg



DN	15	25	40	50	80	100	150	200
FTF	130	160	200	230	310	350	480	457
A	65	80	100	115	155	175	240	228.5
H	48	82	96	103	134	153	210.5	265
H1	109	144	158	165	192.75	219	-	-
E	19	19	19	19	23	19	29	42
F	12	12	12	12	12	12	18	34
G	-	15	15	15	18	18	17	-
M	-	M12	M12	M12	M16	M16	M24	-
L	141	141	206.5	206.5	350	350	-	-
SW	12	12	12	12	16	20	24	34
DIN ISO Connection	F05	F05	F05	F05	F07	F07	F14	F16
ØK	65	85	110	125	160	180	240	295
nxØP	4x14	4x14	4x18	4x18	8x18	8x18	8x22	8x22
Weight	5	6.5	11	14	26	37	65	145

NPS	1/2	1	1 1/2	2	3	4	6	8
FTF	108	127	165	178	203	229	267	419
A	54	63.5	82.5	89	101.5	114.5	133.5	209.5
H	48	82	96	103	138.5	153	216	265
H1	109	144	158	165	192.75	211	-	-
E	19	19	19	19	19	27	25	42
F	12	12	12	12	12	20	18	34
G	-	15	15	15	18		17	-
M	-	M12	M12	M12	M16		M24	-
L	141	141	206.5	206.5	350	350	-	-
SW	12	12	12	12	16	20	24	34
DIN ISO Connection	F05	F05	F05	F05	F07	F07	F14	F16
ØK	60.3	79.2	98.6	120.7	152.4	190.5	241	298
nxØP	4x15.7	4x15.7	4x15.7	4x19.1	4x19.1	8x19.1	8x22.2	8x22.2
Weight	4	5.5	9.5	11	18	29	65	120

Table 6 - Dimensions in mm and weights in kg

Selection and sizing of the drain ball valve:

1. Determine the required nominal size
2. Select valve in accordance with table 2 resp. 3 and by pressure-Temperature diagram
3. Select the appropriate actuator using table 5
4. Select additional equipment

Order text:

BR 20a PTFE-ball valve

DN

PN

optional special version

Lever, resp. actuator (brand name):

Supply pressure: bar

Fail-safe position:

Limit switch (brand name):

Solenoid valve (brand name):

Positioner:

Other:



Note:

All relevant details regarding the version ordered, which deviate from the specified version in this technical description data, can be taken if required, from the corresponding order confirm