



BR 23e · PTFE-lined Potary plug valve DIN- and ANSI-Version



Applications

PTFE-lined rotary plug valve for aggressive media, especially due to high demands in chemical plants:

- **Nominal size DN 25, DN 50 and DN 80 as well as NPS1, NPS2 and NPS3** (DN 100 and NPS4 in preparation)
- **Nominal pressure PN 10 and cl150**
- **Temperatures -10°C to 200°C (14°F to 392°F)**

The valve consists of a PTFE-lined rotary plug valve and a pneumatic actuator.

The valve is designed to the modular-assembly principle and has the following features:

- Pocket free, with a high flow capacity
- Double eccentric
- One-pieced body lining consisting of chemical-resistant PTFE (average body lining, 5 mm)
- Live-loaded PTFE V-ring packing to seal stem
- Bottom end of stem without any leakage (closed liner)
- Possible attachments acc. DIN ISO 5211
- DIN face-to-face dimensions acc. to DIN EN 558, Series 1
- ANSI face-to-face dimensions acc. to DIN EN 558, Series 37

Versions

BR 23e PTFE-lined Rotary plug valve, optionally in the following versions:

- Manually operated rotary plug valve with manual gear
- Automated rotary plug valve with shut-off function, with BR 31a Quarter-turn actuator
- Automated rotary plug valve with control function, optimally with BR 30a Multi-turn actuator (refer to data sheet for details)

Special designs

- Various Kvs coefficients
- PTFE-conductive lining
- Heating
- Various materials on request

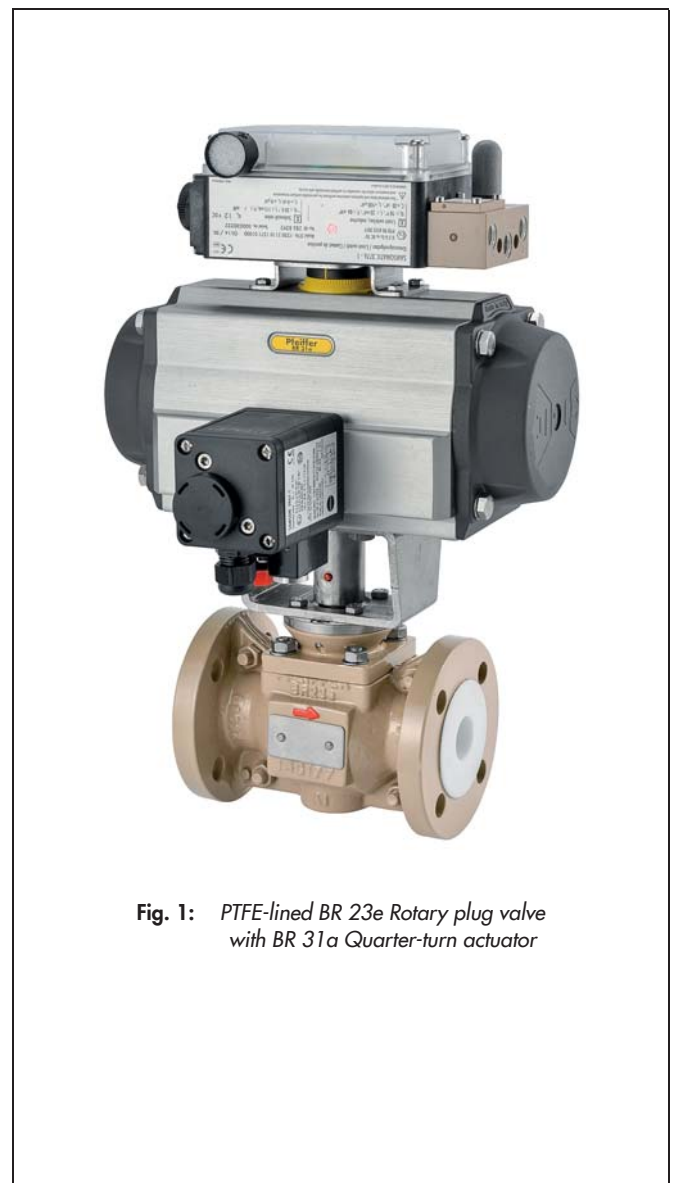

Fig. 1: PTFE-lined BR 23e Rotary plug valve with BR 31a Quarter-turn actuator

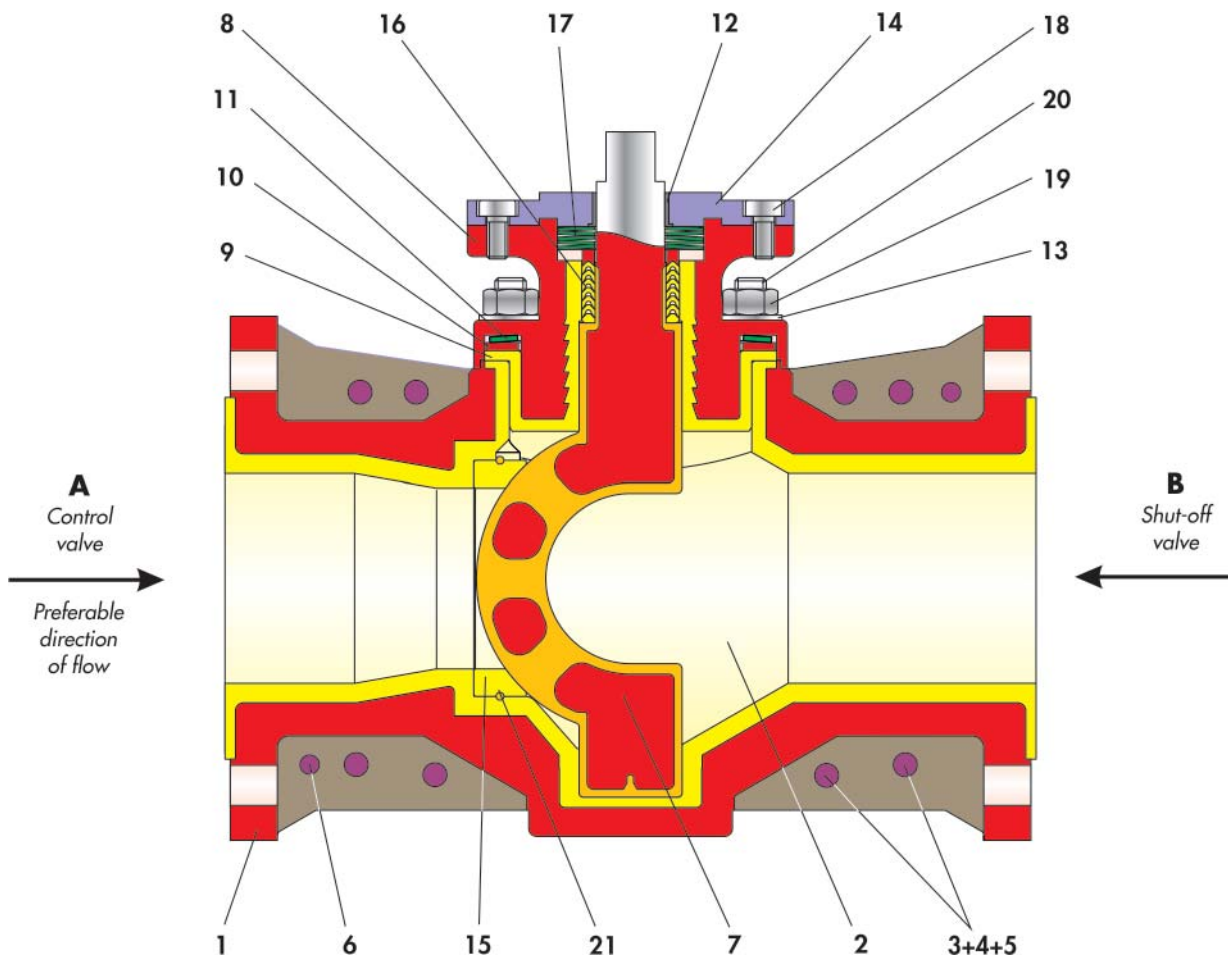

Fig. 2: Sectional drawing of the Rotary plug valve

Table 1: List of parts

Item	Description
1	Rotary plug valve body
2	Liner for valve body
3	Screw
4	Washer
5	Nut
6	Straight pin
7	Rotary plug
8	Bonnet flange
9	Liner for bonnet flange
10	Thrust ring
11	Spring washer

Item	Description
12	Bearing bushing
13	Washer
14	Stuffing box
15	Seat ring
16	V-ring packing
17	Set of spring washers
18	Screw
19	Nut
20	Stud bolt
21	Cord

Function and operating principle

The BR 23e Rotary plug valves permit full flow through the valve in both directions.

The position of the rotary plug (7) determines the flow rate between the rotary plug and seat ring (15).

The seat ring is used to seal the rotary plug.

The version illustrated ensures excellent shut-off performance, a large flow capacity and easy replacement of the seat ring.

The stem is sealed by a maintenance-free PTFE V-ring packing (16) loaded by spring washers (17) located above the packing.

The actuator is mounted on a mounting flange. The connecting dimensions conform to DIN ISO 5211.

i Note

Before using the rotary plug valve in hazardous areas, check whether this is possible according to ATEX 2014/34/EU. See Operating Instructions ► BA 23e.

Direction of flow

When the process medium flows through the valve in direction **A**, the rotary plug is slightly pressed out of the seat. This reduces the pre-loaded pressure and the breakaway torque.

When the process medium flows through the valve in direction **B**, the pre-loaded pressure increases, with a rise in the breakaway torque.

Fail-safe position

Depending on how the pneumatic actuator is mounted to the valve, the rotary plug valve has two fail-safe positions which become effective when the air pressure in the actuator is relieved or when the supply air fails:

- **Rotary plug valve with actuator fail-to-close**

On failure of the air supply, the rotary plug valve closes. The rotary plug valve opens as the signal pressure rises, overcoming the force of the springs.

- **Rotary plug valve with actuator fail-to-open**

On failure of the air supply, the rotary plug valve opens. The rotary plug valve closes as the signal pressure rises, overcoming the force of the springs.

Advantages of the live-loaded sealing system

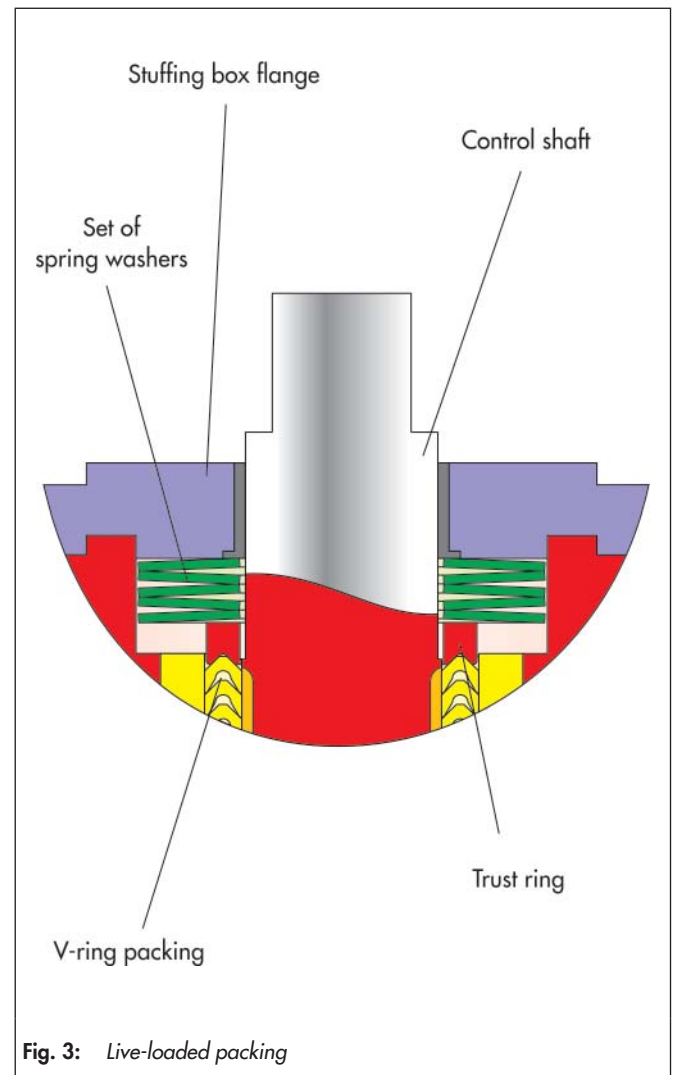

Fig. 3: Live-loaded packing

- Maintenance-free and self-adjusting
- Highest level of sealing performance, even under extreme pressure and temperature changes
- Longer service life

All in all: extremely economic!

Additional equipment

For the control valves, the following accessories are available either individually or in combination:

- Pneumatic and electric actuators
- Positioner
- Limit switch
- Solenoid valves
- Air pressure reducing stations with filter

Further accessories are available on request for customer specifications

Table 2: General technical data

	DIN	ANSI
Nominal size	DN 25, DN 50 and DN 80	NPS1, NPS2 and NPS3
Nominal pressure	PN 10	cl150
Temperature range	-10°C to 200°C (14°F to 392°F)	
Rotary plug sealing	PTFE	
Leakage shut-off valve	Leakage rate A acc. to DIN EN 12266-1, P12 (Leakage rate 1 BO acc. to DIN 3230 Part 3)	
Leakage control valve	0,001% of kvs-coefficient	
Flanges	As per DIN EN 1092-1, Form B1	
Stuffing box flange	Cup live-loaded V-ring packing	
Face to face dimensions	acc. to DIN EN 558, Series 1	acc. to DIN EN 558, Series 37

Table 3: Materials

Rotary plug valve body	0.7043
Liner for valve body	PTFE
Bonnet flange	0.7043
Liner for bonnet flange	PTFE
Rotary plug and shaft	1.4313 with TFM-coating
Seat ring	PTFE
V-ring packing	PTFE V-ring packing with spring washers of 1.8159 / Delta Tone coated
Bearing bushing	PTFE with 25% carbon
Spring washer	1.8159
Coating	2-Components Pur-Varnish colour grey beige, (RAL 1019)

Characteristic curve

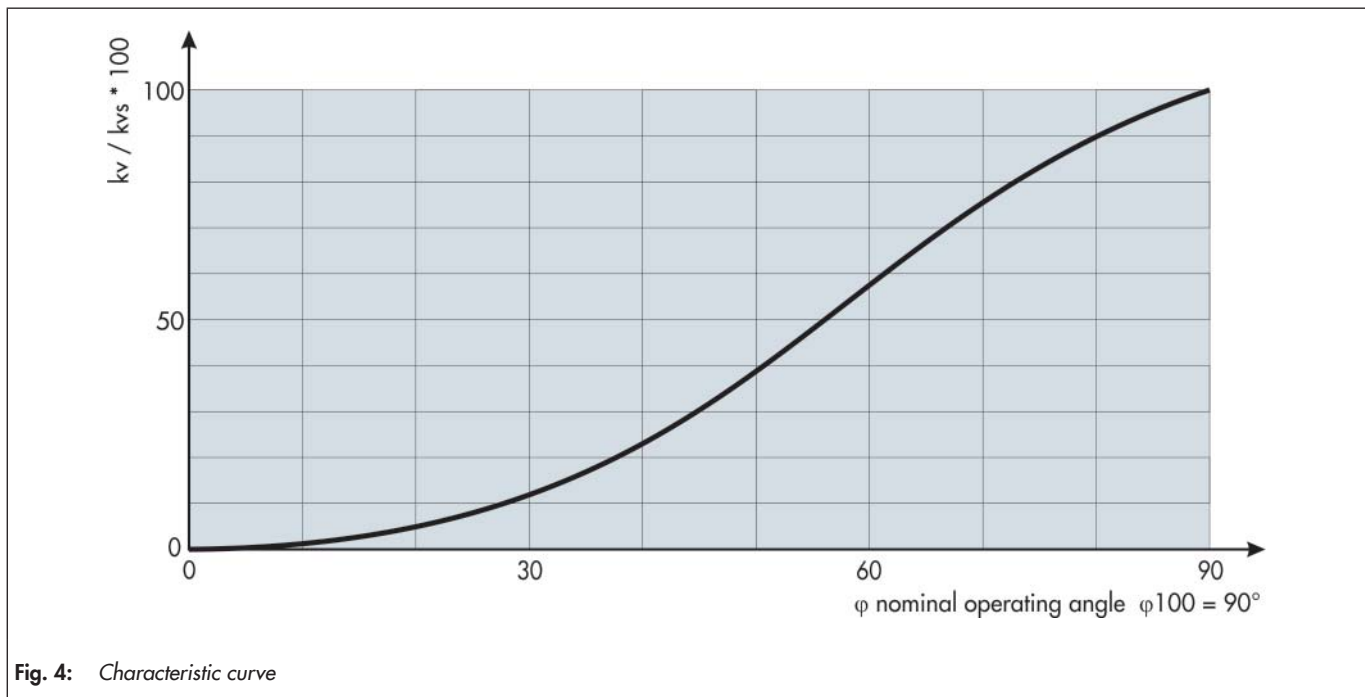

Fig. 4: Characteristic curve

Pressure-temperature diagram

The area of application is determined by the pressure-temperature diagram. Process data and the process medium can affect the values in the diagram.

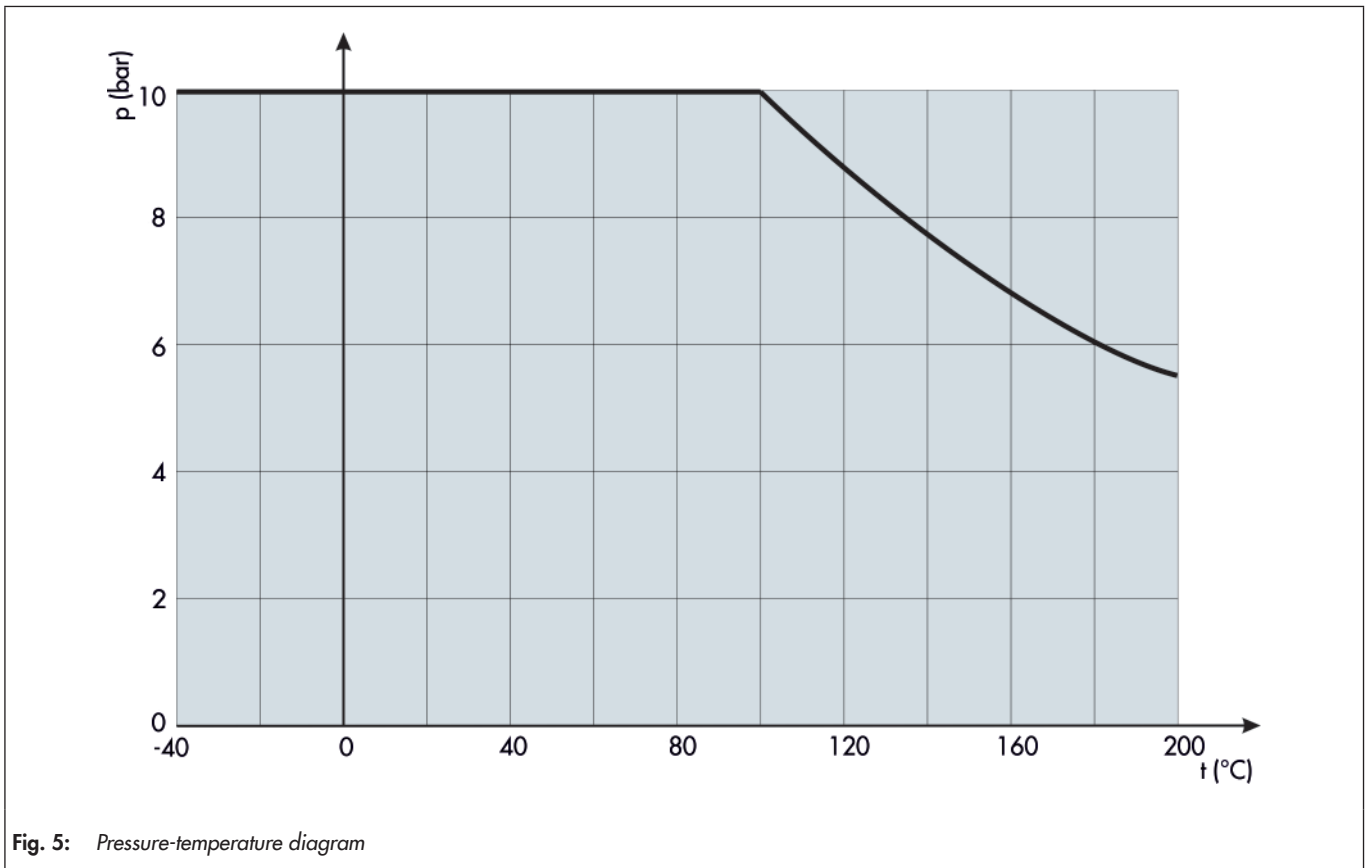

Fig. 5: Pressure-temperature diagram

Avoidance of flashing or cavitation

The operating data for the control application need to be calculated to avoid flashing or cavitation.

The following formula applies:

- a) $\Delta p < P_2$
- b) $\Delta p < 3 \text{ bar}$

Table 4: Max. permissible torque and breakaway torque

Differential pressure		Δp in bar		0	2	4	6	8	10	
		Δp in lbs		0	30	60	90	120	150	
DN	perm. Torque MDmax in Nm	Req. Torque Md in Nm	Breakaway torque Mdl in Nm							
25 / 1"	217	7	10	13	13	13	13	13	18	
50 / 2"	417	20	29	30	30	30	30	30	36	
80 / 3"	761	50	74	74	78	81	85	85	104	

The above listed torques are based on the opening of the ball valve at the differential pressure for water with corrosion inhibitors added at room temperature and with one-day non-actuation.

Since temperature, pressure, process medium, switching frequencies and idle times considerably affect the arising torques, corresponding factors need to be taken into consideration on selecting and sizing the actuator. In case of doubt, contact Pfeiffer.

The listed maximum permissible torques apply to the standard material listed in Table 3.

Table 5: Terms for noise level calculation

z values for noise level calculation acc. to VDMA 24422

DN	25 / 1"	50 / 2"	80 / 3"
z	0.15	0.15	0.1

Correction terms

- With liquids $\Delta LF = 0$,
- With gases and vapor $\Delta LG = 0$

Table 6: Terms for control valve sizing

For control valve sizing acc. to DIN EN 60534 opening angle.

Opening angle φ	30°	40°	50°	60°	70°	80°	90°
FL	0.75	0.73	0.72	0.70	0.59	0.55	0.55
XT	0.47	0.45	0.44	0.41	0.30	0.26	0.25

Table 7: kvs - values

DN / NPS \ kvs	kvs								
	6.3	10	16	25	30	40	63	80	100
25 / 1	X	X							
50 / 2	X	X	X	X	X				
80 / 3				X	X	X	X	X	X

Table 8: kvs and Cv-values

DN / NPS		Opening angle φ								
		10°	20°	30°	40°	50°	60°	70°	80°	90°
25 / 1	kvs	0.05	1.2	2.6	5.3	9.1	14	20	24	26
	Cv	0.06	1.4	3.1	6.2	11	16	23	28	31
50 / 2	kvs	0.22	3.2	11	21	39	60	86	108	114
	Cv	0.26	3.7	12	25	46	70	101	126	133
80 / 3	kvs	0.35	16	38	67	105	152	219	264	280
	Cv	0.41	19	45	79	123	178	256	308	327

Dimensions and weights

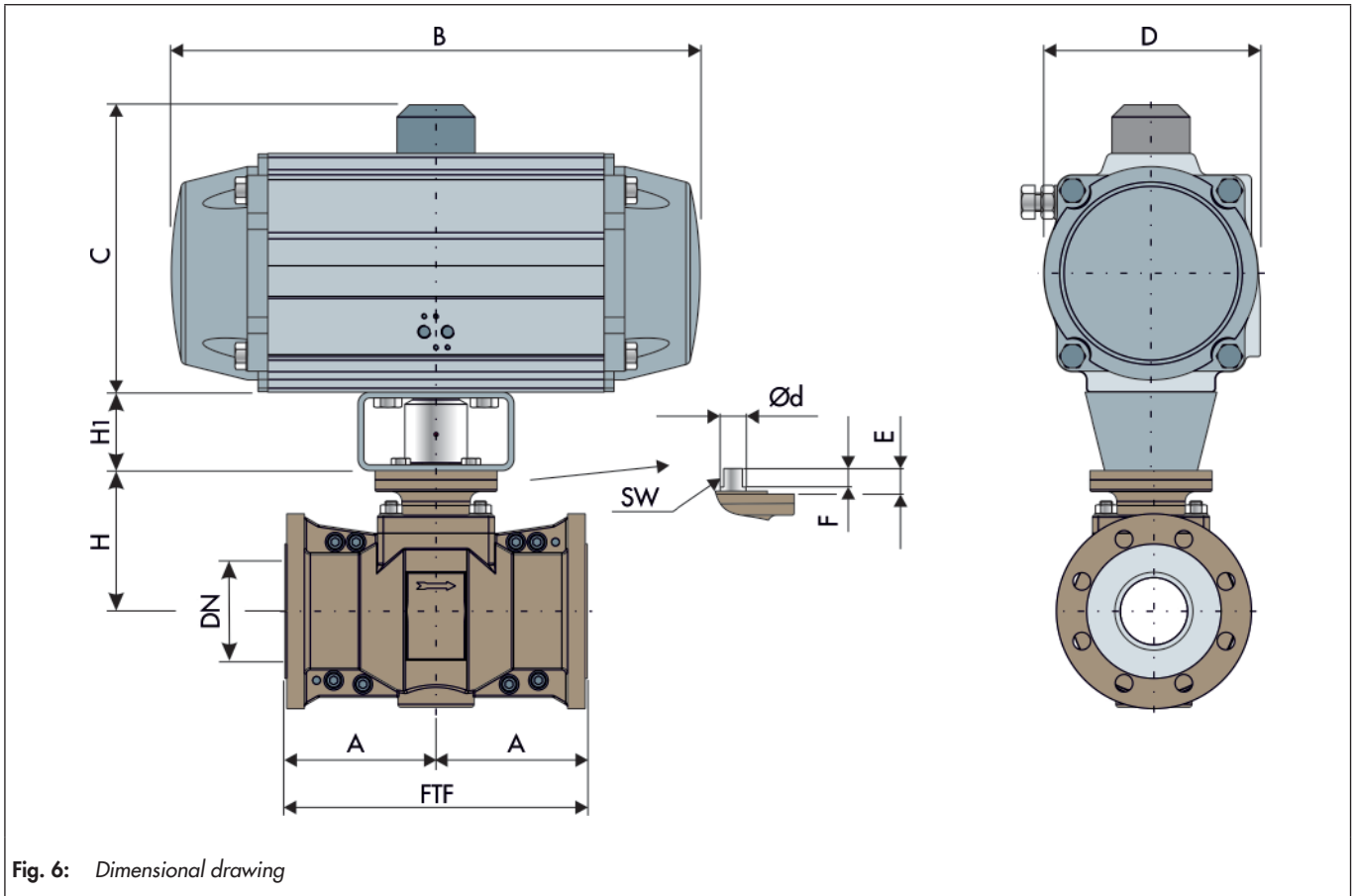

Fig. 6: Dimensional drawing

Table 9: Dimensions in mm and weights in kg

DN / NPS	25 / 1	50 / 2	80 / 3	
FTF	PN 10	160	230	310
	ANSI 150 lbs	184	254	298
A	PN 10	80	115	155
	ANSI 150 lbs	92	127	149
E	21	21.7	26.2	
F	15	17	19	
H	65	100.8	144.3	
d	20	22	27	
DIN ISO Connection	F05	F07	F10	
SW	14	17	19	
Weight in kg	ca. 8	ca. 12	ca. 31	

Actuator Series 31a, SRP	60	100	150	220	300	450	600	900	1200
B	210.5	247.5	268.5	315	345	408.5	437.5	487	543
C	102	115	127	145	157	177	196	220.5	245
D	94.5	106.3	123	141	151.5	171.5	187	204	222
DIN ISO	F05	F07	F07	F10	F10	F12	F12	F14	F14
Square end	14	17	17	22	22	27	27	36	36
max. weight	3.2	4.4	6.5	9.8	12.6	18.1	24	31.6	45.1

Valve	F05	F05	F07	F05	F07	F10	F05	F07	F10	F12	F07	F10	F12	F14
Actuator	F05	F07	F07	F10	F10	F10	F12	F12	F12	F12	F14	F14	F14	F14
H1	60			80						90				

Selecting and sizing the rotary plug valve

1. Calculate the appropriate Kv coefficient
2. Select the valve using Table 2, Table 3 and the Pressure-temperature diagram
3. Select a suitable actuator from Table 9
4. Additional equipment

Ordering text

Rotary Plug Valve Series 23e

Nominal size: DN / NPS

Nominal pressure: PN / ANSI Class

optional special version

Manual gear actuator or actuator (brand name):

Supply pressure: bar,

fail-safe position:

Limit switch (brand name):

Solenoid valve (brand name):

Positioner:

Others:

Associated data sheets

- For pneumatic Multi-turn actuator ▶ TB 30a
- For pneumatic Quarter-turn actuator ▶ TB 31a

Note

All relevant details regarding the version ordered, which deviate from the specified version in this technical description data, can be taken if required, from the corresponding order confirm
